



GENESEE COUNTY PLANNING BOARD REFERRALS NOTICE OF FINAL ACTION

GCDP Referral ID

T-02-BYR-04-23

Review Date

4/13/2023

Municipality
Board Name
Applicant's Name
Referral Type
Variance(s)
Description:

BYRON, T.

PLANNING BOARD

Cypress Creek Renewables/Leatherleaf Solar LLC

Special Use Permit

Special Use Permit and Site Plan Review for a 35 acre, 5 MW ground mounted commercial solar energy system.

Location
Zoning District

Ivison Rd., Byron

Agricultural Residential (A-R) District

PLANNING BOARD RECOMMENDS:

APPROVAL WITH MODIFICATION(S)

EXPLANATION:

The required modifications are as follows: 1) Given that the project parcel is enrolled in Agricultural District No. 4 and that the project will receive public funding, the applicant comply with NYS Agriculture and Markets Law Section 305 (Notice of Intent provision); and 2) the applicant amend the decommissioning plan to include decompaction of the footprint of the access road/equipment pads where they occur in currently farmed areas of the field to a minimum of 24 inches beneath the bottom of the former stone layer and post-decommissioning monitoring for a minimum of three growing seasons. With these required modifications, the proposed solar energy system should pose no significant county-wide or intercommunity impact. It is recommended that the applicant submits the enclosed application for 9-1-1 Address Verification to the Genesee County Sheriff's Office to ensure that the address of the proposed solar system meets Enhanced 9-1-1 standards.

Director

April 13, 2023

Date

If the County Planning Board disapproved the proposal, or recommends modifications, the referring agency shall NOT act contrary to the recommendations except by a vote of a majority plus one of all the members and after the adoption of a resolution setting forth the reasons for such contrary action. Within 30 days after the final action the referring agency shall file a report of final action with the County Planning Board. An action taken form is provided for this purpose and may be obtained from the Genesee County Planning Department.

SEND OR DELIVER TO:

GENESEE COUNTY DEPARTMENT OF PLANNING
3837 West Main Street Road
Batavia, NY 14020-9404
Phone: (585) 548-7123

DEPARTMENT USE ONLY:

GCDP Referral # T-02-BYR-04-23



*** GENESEE COUNTY *
PLANNING BOARD REFERRAL**

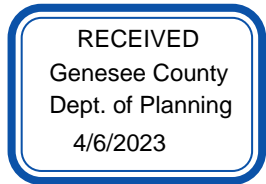

Required According to:
GENERAL MUNICIPAL LAW ARTICLE 12B, SECTION 239 L, M, N
(Please answer ALL questions as fully as possible)

1. REFERRING BOARD(S) INFORMATION

Board(s) Town of Byron Planning Board

Address PO Box 9 7028 Byron Holley Rd.

City, State, Zip Byron, NY 14422

Phone (585) 548 - 7123 Ext. 15

2. APPLICANT INFORMATION

Name Cypress Creek Renewables/Leatherleaf Solar LLC

Address PO Box 173

City, State, Zip Latham, NY 12110

Phone (828) 269 - 4446 Ext. _____ Email bernardo.urdaneta@ccrenew.com

MUNICIPALITY: City Town Village of Byron

3. TYPE OF REFERRAL: (Check all applicable items)

- | | | |
|--|--|---|
| <input type="checkbox"/> Area Variance | <input type="checkbox"/> Zoning Map Change | <input type="checkbox"/> Subdivision Proposal |
| <input type="checkbox"/> Use Variance | <input type="checkbox"/> Zoning Text Amendments | <input type="checkbox"/> Preliminary |
| <input checked="" type="checkbox"/> Special Use Permit | <input type="checkbox"/> Comprehensive Plan/Update | <input type="checkbox"/> Final |
| <input type="checkbox"/> Site Plan Review | <input type="checkbox"/> Other: _____ | |

4. LOCATION OF THE REAL PROPERTY PERTAINING TO THIS REFERRAL:

A. Full Address 7501 Ivison Rd.

B. Nearest intersecting road Freeman or Coward Rds.

C. Tax Map Parcel Number 9.-1-7.113

D. Total area of the property 179 acres Area of property to be disturbed 35 acres

E. Present zoning district(s) AR

5. REFERRAL CASE INFORMATION:

A. Has this referral been previously reviewed by the Genesee County Planning Board?
 NO YES If yes, give date and action taken _____

B. Special Use Permit and/or Variances refer to the following section(s) of the present zoning ordinance and/or law
11.15

C. Please describe the nature of this request Installation of solar ground mounted panels, over head and underground electric, 7 ft. perimeter chain link fencing.

6. ENCLOSURES – Please enclose copy(s) of all appropriate items in regard to this referral

- | | | |
|---|--|--|
| <input checked="" type="checkbox"/> Local application | <input type="checkbox"/> Zoning text/map amendments | <input type="checkbox"/> New or updated comprehensive plan |
| <input checked="" type="checkbox"/> Site plan | <input checked="" type="checkbox"/> Location map or tax maps | <input type="checkbox"/> Photos |
| <input type="checkbox"/> Subdivision plot plans | <input type="checkbox"/> Elevation drawings | <input type="checkbox"/> Other: _____ |
| <input checked="" type="checkbox"/> SEQR forms | <input type="checkbox"/> Agricultural data statement | |

7. CONTACT INFORMATION of the person representing the community in filling out this form (required information)

Name Melissa Ierlan Title CEO/ZEO Phone (585) 402 -0148 Ext. _____

Address, City, State, Zip _____ Email townofbyrocodes@gmail.com



Leatherleaf Solar, LLC 5.00 MW COMMUNITY SOLAR FACILITY

Prepared by: Leatherleaf Solar, LLC
Town of Byron Special Use Permit, Site Plan Application
March 23, 2023

[Page intentionally left blank]

Town of Byron Special Use Permit, Site Plan Approval Application Leatherleaf Solar, LLC 5.0 MW Solar Energy Facility

Submitted by Leatherleaf Solar, LLC
P.O. Box 173 Latham, NY 12110

COMPANY SUMMARY

Leatherleaf Solar, LLC is a limited liability company that is owned by Cypress Creek Renewables, LLC (CCR). CCR is driven by the belief that solar makes our world safer and cleaner while also creating good jobs and contributing to our country's energy independence. CCR is recognized as an industry leader in providing clean, affordable energy throughout the U.S. Our team members specialize in the design, build, and ownership of a range of solar projects, and the company has invested over \$3 billion into solar energy production since 2009. CCR is committed to providing positive benefits to the communities we serve, and we hope to be an asset to your community.

Leatherleaf Solar, LLC, the Applicant, has prepared this application for a 5.0 MW Solar Energy Facility in the Town of Byron, New York. This application was prepared according to the requirements detailed in the Town of Byron's Solar Ordinance Local Law No. 2-2019. Leatherleaf Solar, LLC respectfully submits information, exhibits, and materials, which are hereby incorporated into and made part of the Application below in order to comply with the Town of Byron Permit Approval Criteria.

PROJECT SUMMARY

Leatherleaf Solar, LLC proposes to develop a 5.0 MW Solar Energy Facility on a roughly 35-acre tract of land located at 7501 Ivison Road, Byron, and owned by Dean Ivison. The project site is located near the intersection of Ivison Road and Freeman Road, consisting of parcel 9.-1-7.113.

Leatherleaf Solar will contain approximately 10,000 Photovoltaic (PV) cell panels mounted on posts set in the ground. The anticipated power output of the project annually will be enough to power approximately 1,000 single-family homes, and the project will deliver that power onto the grid through coordination with National Grid.

Cypress Creek Renewables has contracted environmental consultants to perform field investigations, literature reviews, and agency consultations to identify and assess existing environmental conditions at the project site. Information derived from the environmental diligence is used by CCR to avoid and minimize effects to environmental resources during the design process, and supporting information is presented in the Full Environmental Assessment Form (FEAF) included with this submittal (Exhibit B). Full compliance with federal, state and local regulations will ensure Leatherleaf Solar will not result in adverse impacts to environmental resources.

CCR is a proud partner of each town that we work with, and we look forward to a continued relationship with the Town of Byron.

PROJECT BENEFITS

Allowing the property to develop as a solar energy facility provides many benefits, including:

- **The creation of locally generated, clean energy resources in Byron**
- **A source of consistent, annual income for the landowners.**
 - This is especially helpful when the landowner's occupation provides variable income, as is often the case year-to-year for farmers.
- **Contribution to renewable energy goals outlined by the State of New York.**
 - Leatherleaf Solar will provide \$88,408 per year in economic value¹ to the State of New York and the Town of Byron by offsetting 2,363 tons of CO₂ annually.
- **Improved soil and agricultural productivity for local farmland resulting from the installation of an on-site pollinator habitat**
 - Through planting and managing native, pollinator-friendly vegetation, Leatherleaf Solar, LLC can reduce storm water runoff by 8–23% and support the development of wild pollinators, such as bees and insects, which are vital for the crop yield of pollinator-dependent crops worth \$344 million across New York.^{2&3}

APPLICATION FOR SITE PLAN AND SPECIAL USE PERMIT APPROVAL

The following Application and supporting documents address the Town of Byron Special Use Permit, Site Plan Approval Application criteria.

Once applicable permits have been obtained, Leatherleaf Solar, LLC will construct, own, operate and maintain the solar energy facility. The project will be a low-impact development requiring little to no local municipal services. The attached application illustrates that this project will not negatively impact public safety or general welfare, nor will it affect the comfort and convenience of the public in Byron or of the immediate neighborhood.

Leatherleaf Solar, LLC respectfully requests approval of a Special Use Permit and Site Plan review to construct a 5.0 MW Solar Energy Facility. We thank you for your consideration and look forward to working together to bring the benefits of a solar energy facility to the Town of Byron. Please let me know if I can provide additional information or assistance.

Sincerely,

Bernardo Urdaneta
828-269-4446
bernardo.urdaneta@ccrenew.com
Cypress Creek Renewables

¹Technical Support Document: Technical Update of the Social Cost of Carbon for Regulatory Impact Analysis Under Executive Order 12866 (May 2013, Revised August 2016)

²Bryan Danforth and Maria van Dyke, "Wild Bees of New York" accessed February 6, 2018. <https://pollinator.cals.cornell.edu/wild-bees-new-york>. Web.

³"Soil, Crop, & Storm Water Benefits of Solar Sites." Fresh Energy, 22 Mar. 2016. Web.

CONTENTS

Company Summary.....	3
Project Summary	3
Project Benefits	4
Application for Special Use Permit, Site Plan Review	4
Special Use Permit, Site Plan Review APPROVAL CRITERIA.....	7
A. Town of Byron Special Use Permit and Site Plan Application	7
1. APPLICANT INFORMATION.....	100
1.1 APPLICANT ADDRESS AND CONTACT	100
1.2 BACKGROUND ON CYPRESS CREEK RENEWABLES, LLC AND LEATHERLEAF SOLAR, LLC .	10
1.3 PROJECT FINANCES	1
1.3.1 Project Costs and Financing Structure.....	
1.3.2 Economic Development.....	10
2. PROJECT DESCRIPTION AND ANALYSIS	11
2.1 PROJECT PURPOSE AND NEED	
2.2 PROJECT OVERVIEW	11
2.3 BENEFITS OF THE PROJECT.....	13
2.3.1 Project Benefits.....	13
2.3.2 Collocation of Agricultural Uses.....	13
2.4 SOLAR ENERGY OVERVIEW	1
2.4.1 Solar Energy Technology.....	
2.4.2 Solar Energy Facility Equipment	
2.4.3 Site Access.....	14
2.4.4 Interconnection With the grid	
2.5 BYRON PROJECT SITE DESCRIPTION AND SITING	15
2.5.1 Site Selection Process	
2.5.2 Surrounding Terrain	
2.6 CONSTRUCTION ACTIVITIES.....	16
2.6.1 Construction Sequence	
2.6.2 Construction Materials	
2.7 OPERATION AND MAINTENANCE	17
2.7.1 Equipment Maintenance	17
2.7.2 Vegetation Maintenance	17
2.7.3 Decommissioning of Site.....	18
2.8 SOLAR ENERGY FACILITY SAFETY	19
2.9 TRAFFIC SAFETY	19

2.10 AGENCY COORDINATION	19
3. Exhibits	20
Exhibit A. Civil Site Plans	
Exhibit B. SEQR Full Environmental Assessment	
Exhibit C. Three Line Diagram	
Exhibit D. Preliminary Equipment Specification Sheets	
Exhibit E. Special Use Permit Application	
Exhibit F. O&M and Vegetation Management Plan	
Exhibit G. SWPPP	
Exhibit H-1. Decommissioning Plan	
Exhibit H-2. Decommissioning Cost Estimate	
Exhibit I. NYSDAM Guidelines for Solar Energy Projects.....	
Exhibit J. Visual Impact Assessment	
Exhibit K. Technical Memo	

Site Plan & Special Use Permit APPROVAL

CRITERIA

A. REVIEW OF TOWN OF BYRON LOCAL LAW #XX OF 2020 RELATING TO SOLAR ENERGY SYSTEMS

Definitions and General Requirements (§ 2.02c and § 2.02e)

1. Leatherleaf Solar is in the Agricultural-Residential (R) zoning district. This project would be classified as a Tier 4 Solar Energy System, which includes any solar energy system greater than 15 acres in size.
2. Tier 4 Solar Energy Systems shall be considered a permitted use requiring the issuance of a Building and Zoning permit as well as a review pursuant to the State Environmental Quality Review Act (SEQRA)

Permitting Requirements (§ 2.02h (viii))

All applications for Tier 4 Solar Energy Systems shall include the following information:

1. Drawings of the solar photovoltaic installation stamped and signed by a licensed Professional Engineer showing the proposed layout of the system and any potential shading from nearby structures.

Please see Exhibit A for Civil Site Plans and refer to drawing C-200

2. Proposed changes to the landscape of site, grading, vegetation clearing and planting, exterior lighting, screening vegetation or structures.

Please see Exhibit A for Civil Site Plans and refer to drawing L-100 and L-500

3. A three-line electrical diagram detailing the Solar Energy System layout, solar collector installation, associated components, and electrical interconnection methods, with all National Electric Code compliant disconnects and over current devices.

Please see Exhibit C for Three-line D

4. A preliminary equipment specification sheet that documents all proposed solar panels, significant components, mounting systems, and inverters that are to be installed.

Please see Exhibit D for Equipment Specification sheet

5. Name, address, and contact information of proposed system installer and owner of

the Solar Energy System

Please see page 12 of this document for information about Leatherleaf Solar, LLC and Cypress Creek Renewables

6. Name, address, phone number and signature of the project applicant, as well as the property owner, demonstrating their consent to the application and the use of the property for the Solar Energy System

Please see Exhibit E for Special Use Permit Application Form

7. Zoning district designation for the parcel of land comprising the project site

Please see Exhibit E for Special Use Permit Application Form – Question #3.

8. Property Operation and Maintenance Plan.

Please see Exhibit F for O&M and Vegetation Management Plan

9. Erosion and sediment control and stormwater management plans prepared to New York State Department of Environment Conservation Standard

Please see Exhibit G for the WPPP

Other Application Requirements

- A decommissioning plan shall be submitted by the owner of the Solar Energy System addressing the follow **§ 2.02h (vii) 2**):
 - The cost of removing the Solar Energy System
 - The time required to decommission and remove the Solar Energy System and any ancillary structures
 - The time required to repair any damage caused to the property by the installation and removal of the Solar Energy System

Please see Exhibits H-1 and H-2 for Decommissioning Plan and Decommissioning Cost Estimate

- Tier 4 Solar Energy Systems located on Prime Farmland shall be constructed in accordance with the requirements of the New York State Department of Agriculture and Markets Guidelines for Agricultural Mitigation for Solar Energy Projects **§ 2.02h (ix) 7.II**)

Please see Exhibit I for the executed NYSDAM guidelines showing Leatherleaf Solar's commitment to adhere to them during the different stages of the project

- Tier 4 Solar Energy Systems owners shall develop, implement, and maintain native vegetation pursuant to a vegetation management pl **§ 2.02h (ix) 7.III**)

Please see Exhibit F for the O&M and Vegetation Management Plan

- Solar Energy Systems larger than 10 acres shall be required to conduct a visual assessment of the visual impacts of the Solar Energy System on public roadways and adjacent properties **§ 2.02h (ix) 6.II)**

Please see Exhibit J for Visual Impact Assessment

1. APPLICANT INFORMATION

1.1 APPLICANT ADDRESS AND CONTACT

Company:

Cypress Creek Renewables
P.O. Box 173
Latham, NY 12110

Contact:

Bernardo Urdaneta
Phone: 828-26
Email: bernardo.urdaneta@ccrenew.com

1.2 BACKGROUND ON CYPRESS CREEK RENEWABLES AND LEATHERLEAF SOLAR, LLC

Cypress Creek Renewables believes solar energy makes the world, safer, cleaner, and better. With more than 5.9 gigawatts of solar energy developed in eighteen states and \$3 billion in solar energy production since 2014, CCR is one of the country's leading solar companies and was recognized by Solar Power World magazine as the No. 1 Solar Developer in the U.S. for 2017 and 2018. For more information about CCR, please visit <https://ccrenew.com>.

CCR team members have a wealth of experience in the solar industry and work to develop, build, and operate solar facilities across the United States. We are committed to strong partnerships with utility companies, financial institutions, and the communities that host our solar energy facilities. As a national leader in solar energy, and a partner with many communities in New York already, Cypress Creek is the right partner for the Byron community.

1.3 PROJECT FINANCES

1.3.1 PROJECT COSTS AND FINANCING STRUCTURE

Leatherleaf Solar, LLC expects to invest approximately \$10,000,000 into the project. These costs are based on build cost assumptions and include all construction, material, labor, and professional service-related expenditures. Cypress Creek Renewables operating capital, in combination with tax equity and debt partners, will provide the financial backing for the project.

2. PROJECT DESCRIPTION AND ANALYSIS

2.1 PROJECT PURPOSE AND NEED

Solar energy is a vital part of our nation’s economy and energy mix. Conventional sources of electricity such as coal, gas, and nuclear energy are expensive, finite resources that require significant environmental disruption and public safety risk to maintain and extract. Solar energy is a clean, cheap, and unlimited resource with little environmental impact. Technological advancements have made solar energy cost competitive with power generated by fossil fuels and with proven storage technologies, we are now able to keep the lights on even when the sun isn’t shining.

New York has identified the advancement of renewable energy and energy efficiency as a state-wide goal. The Climate Leadership and Community Protection Act, adopted by the New York State Legislature in May 2019, stipulates that 70% of energy generation in New York State will be sourced from renewable energy sources by 2030. This mandate requires at least 13,000 MWs of utility-scale solar and onshore wind projects, like Leatherleaf Solar, to be placed in-service by 2030.

Leatherleaf Solar, and similar solar energy facilities, are essential to achieving the sustainability goals of Byron and the State of New York. Each 5. MW solar energy facility that can be placed in New York can offset an estimated 2,200 tons of carbon dioxide annually, the equivalent of 450 cars off the road⁴.

2.2 PROJECT OVERVIEW

Leatherleaf Solar is proposing a 5.0 MW Solar Energy Facility in the Town of Byron. The project will be located at 7501 Ivison Road. The project will be placed on a roughly 35-acre portion of parcel # 9.-1-7.113. The project will have access from Ivison Road. The property is zoned Agricultural Residential and will require Site Plan approval and a Special Use Permit.

Leatherleaf Solar will contain rows of Photovoltaic (PV) cell panels, also referred to as modules, mounted on posts set in the ground. These rows of PV panels are referred to as “solar arrays.” Solar components will comply with the current edition of the National Electric Code, be UL listed (or equivalent), and designed with an anti-reflective coating. The solar panels will be supported by a metal racking system no more than twelve (12) feet in height. The anticipated power output of the project is approximately 9,954,192 kilowatt-hours (kWh) annually, enough to power approximately 1,250 single-family homes.

⁴ US EPA (2015). e. RID, U.S. annual national emission factor, year 2012 data. U.S. Environmental Protection Agency, Washington, DC.

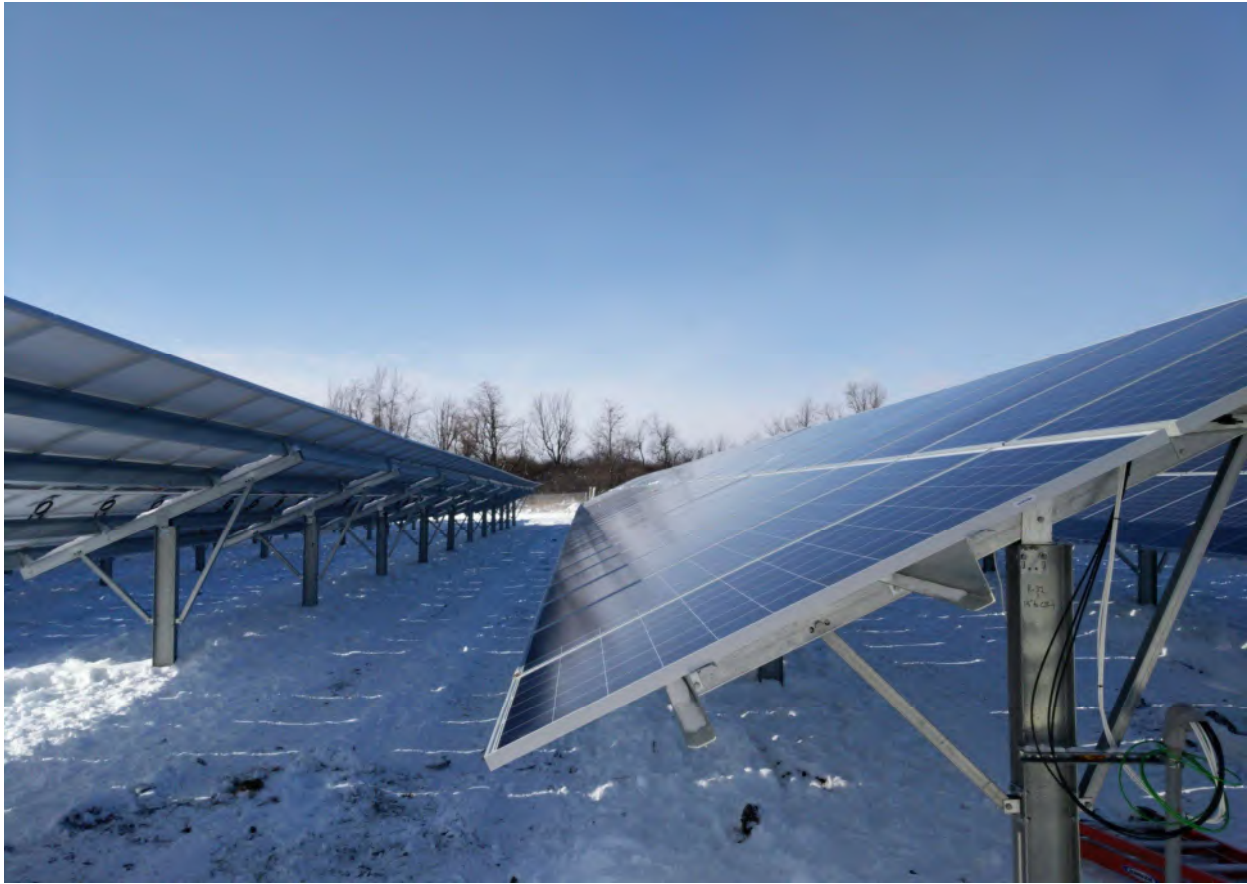

FIGURE 1 JEFFERSON: 2 MW SOLAR ENERGY FACILITY IN WATERTOWN, NEW YORK

The project will not require manned labor on-site, nor will it require sewer, water, or other services. The project will be completely enclosed by a 7-foot-tall fence comprised chainlink and 1-foot of barbwire.

Leatherleaf Solar will not negatively impact the public health, safety, and general welfare, nor the comfort and convenience of the public in general, or the residents of the town or of the immediate neighborhood. In fact, we expect the project will be a benefit to Byron both in economic development as well as in helping the County achieve sustainability goals.

Please see Exhibit K Technical Memo for further information on panel materials, audibility, glare, soil protection, dust and weed control and wildlife protection.

2.3 BENEFITS OF THE PROJECT

2.3. PROJECT BENEFITS

Leatherleaf Solar proposes many benefits to the Town of Byron, the State of New York, and National Grid customers. There are few, if any, costs associated with the project. Benefits are summarized below:

- Increased tax revenue for Byron;
- Contribution to fulfillment of the State of New York Renewable Energy Standard
- Additional income provided to Landowner through lease payments;
- In-state generation to help provide energy independence for the State of New York, which imported 26 million MWh of power in 2018;
- Diversified electrical mix in the grid

2.3.2 COLLOCATION OF AGRICULTURAL USES

Pollinator-Friendly Energy Systems:

Pollinators are crucial to New York State's food supply and agricultural productivity, playing a key role in the size, health, and quality of a wide variety of harvests. As an individual example, 81% of the crop yield for pumpkins and other squash is pollinator-dependent. According to the USDA, pollinators provide approximately \$344 million worth of pollinator services to New York and add \$15+ billion in value to crop production nationally each year.⁵ However, many pollinator species are in decline due to disease, ecosystem destruction, environmental factors, and other issues, hurting thousands of farms across the state.

New York State adopted a Pollinator Protection Plan in June 2016, which recognizes the importance of pollinators, such as bee and insect species, to the agricultural industry by allocating \$500,000 of the 2017-2018 NYS Budget towards Pollinator Protection. CCR's solar facility in the Town of Byron will support the state's efforts to protect pollinator habitats by planting native, pollinator-friendly vegetation on Leatherleaf So

By planting native vegetation and managing it in a way that is hospitable to pollinators, CCR's solar project will benefit nearby agricultural land, support pollinator populations, and improve the aesthetics of the proposed solar arrays. In fact, the presence of healthy insect pollinations can enhance average crop yield between 18-71%, depending on the cr⁶. Additionally, soils rest and rebuild while deep-rooted plants add organic matter and fertile topsoil during the solar farm's operation. This diverse mixing of native plants, with root depths of 4-6 feet, can reduce storm water runoff by 8-23% compared to turf-grasses, which have a maximum root depth of 3-6 inches⁷. Through co-locating pollinator habitats on Leatherleaf Solar, LLC, the project is

⁵ Bryan Danforth and Maria van Dyke, "Wild Bees of New York" accessed February 6, 2018. <https://pollinator.cals.cornell.edu/wild-bees-new-york>. Web.

"Soil, Crop, & Storm Water Benefits of Solar Sites." Fresh Energy, 22 Mar. 2016. Web.

⁶ Bartomeus, Ignasi et al. "Contribution of Insect Pollinators to Crop Yield and Quality Varies with Agriculture Intensification." Ed. Anna Traveset. PeerJ 2 (2014): e328. PMC. Web. 22 June 2017

⁷ "Soil, Crop, & Storm Water Benefits of Solar Sites." Fresh Energy, 22 Mar. 2016. Web.

uniquely poised to support the growth of wild pollinators, improve soil productivity, and increase crop yield for local farmers and surrounding land.

2.4 SOLAR ENERGY OVERVIEW

2.4. SOLAR ENERGY TECHNOLOGY

The conversion of sunlight into electric energy is not a new concept—solar technologies have been around since the 1970s. Our projects are designed, built, and operated to the same rigorous standards as your current energy provider, complying with state and local codes and standards.

2.4. SOLAR ENERGY FACILITY EQUIPMENT

Solar facilities are simple constructions that employ the following basic equipment:

- Solar PV panels
- Inverters
- Transformers
- Wires and conductor cables
- Structural racking system for PV modules
- Perimeter fencing

The solar PV panels function as a solid state, inert crystal, most similar to a pane of solid glass. The panels do not erode and do not produce any emissions. The sealed PV panels do not leach metals into the environment and are recycled at the end of their lifecycle.

Cypress Creek Renewables typically mounts the solar arrays on a tracking system (panels slowly follow the sun throughout the day). Structural frames, also referred to as racks, are driven into the ground with steel beams on which PV panels are mounted. The inverters and transformers, which receive the power from the solar panels, are mounted on top of small concrete pads. Most sites require minimal grading, and an entire facility can often be installed with minimal soil disturbance.

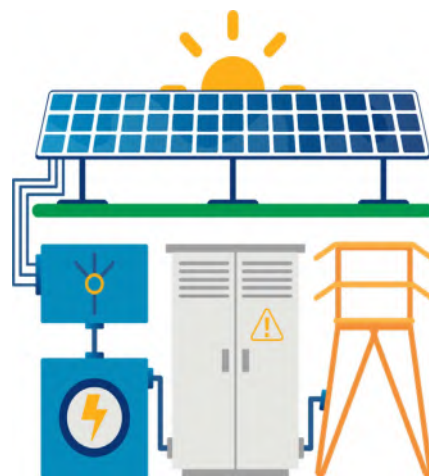

FIGURE 3: SOLAR ENERGY

Solar electricity production includes the following five components:

1. *Electrical Power Generation* – Sunlight strikes the PV panel cells, which convert photons of light into electrons, producing low-voltage, Direct Current (DC) electricity.
2. *Combination box* – The low-voltage, DC electricity is fed through cables from each PV panel to a combiner box.

3. *Inverter* – The low-voltage, DC electricity is fed through cables from the combiner box to an inverter, where it is converted to low-voltage, Alternating Current (AC) electricity
4. *Transformer* – The transformer steps up the low-voltage, AC electricity to the appropriate voltage so that it can be fed into the electrical transmission system.
5. *Utility Transmission* – Electricity is sent through the electrical transmission lines to utility distribution systems for delivery to ratepayers.

Please see Exhibit K – Technical Memo for further information on materials

2.4 SITE ACCESS

Solar energy facilities are low-impact developments that can often utilize existing right-of-way (ROW) infrastructure for site access, minimizing the need for new disturbance for the construction and maintenance of the project.

2.4.4 INTERCONNECTION WITH THE GRID

New solar generating facilities improve local infrastructure and modernize an outdated grid, enabling future energy growth and increasing resilience to power outages.

The existing electrical distribution system in New York is owned and operated by the local utility. In order for a developer of a solar generating facility to inject power into the distribution grid, they must first work with the utility to ensure that the additional proposed generation will be safely and reliably handled by the existing utility infrastructure. The utility conducts studies to model the additional generation on their distribution grid and identifies what infrastructure upgrades are required to plug the proposed generating facility into the grid. The developer of the solar generating facility is then required to pay for the utility to upgrade their infrastructure so that it can adequately support the new generation.

This process results in an improved and upgraded electrical distribution system with the following primary benefits:

- (1) modernization of an outdated grid;
- (2) improved capability to support future load and generation growth;
- (3) increased resilience to power outages through a more updated and distributed grid; and
- (4) cost savings for customers who are normally charged through their utility bills for infrastructure upgrade.

2.5 BYRON PROJECT SITE DESCRIPTION AND SITING

2.5.1 SITE SELECTION PROCESS

CCR uses a spatial and data-driven approach to select potential solar energy facility sites. When deciding whether to execute a lease option for solar development, CCR evaluates land based on the following criteria, among others:

- Proximity to relevant infrastructure, including electrical substations, existing three phase lines, and access roads;
- Lack of wetlands and other protected landforms;

- Slope of land and direction of this slope; and
- Lack of threatened or endangered species.

CCR was able to engage the landowner in their interest in solar development and execute a lease. During the initial development stages, we further analyzed the site against a number of diligence criteria, which verified that the screening process had been effective in selecting an ideal site for a solar energy facility.

Please see Exhibit A for Civil Site Plans and refer to sheets C-200 for exact site location.

2.5. SURROUNDING TERRAIN

The Leatherleaf Solar site is an ideal site for a solar energy facility, considering its access to the existing utility grid and lack of environmental constraints. The project will be located on a portion of a parcel currently utilized for agriculture. The parcel is zoned as Agricultura Residential.

2.6 CONSTRUCTION ACTIVITIES

2.6.1 CONSTRUCTION SEQUENCE

While each site is unique, Leatherleaf Solar will use standard construction and operation procedures used for our other solar energy facilities in New York. The construction of Leatherleaf Solar is expected to take an estimated 16-20 weeks.

As required by New York State Department of Environmental Conservation (NYSDEC), the limit of soil disturbance for all construction activities will be phased to five acres, unless otherwise authorized or waived by NYSDEC.

The utility's engineering, procurement and construction of the interconnection facilities will take an estimated 8 months total and will be complete just before the construction of the solar farm itself. Construction of the solar farm itself will take an estimated 16-20 weeks, depending on site variability. After the construction process is completed, the solar farm will go through 2-3 weeks of commissioning before reaching commercial operation

Proposed construction schedule:

- Construction start date: April 2024
- Commercial operation date: November 2024
- Substantial completion date: December 2024

2.6. CONSTRUCTION MATERIALS

The PV panels do not erode, and do not produce any emissions.⁸ There are no chemicals, fluids, or materials that are capable of entering the environment from the PV panels.

⁸ Electric Power Research Institute and California Energy Commission, August 2003. Potential Health and Environmental Impacts Associated with the Manufacture and Use of Photovoltaic Cells. <<http://www.energy.ca.gov/reports/500-04-053.PDF>> Accessed on February 3, 2017.

The only hazardous material that will be used during the construction of Leatherleaf Solar is fuel for machinery; all other construction materials are non-hazardous. Leatherleaf Solar and its subcontractors will follow all appropriate protocol related to the use and storage of fuel. A sufficient quantity of spill containment and clean up materials shall be readily available at each equipment storage area such that any spill which may occur can be cleaned up immediately. There shall be a drip pan placed at the fueling station so that no fuel can reach the ground. This area shall be inspected daily for spillage and any fuel spillage shall be properly disposed of and a receipt of proper disposal shall be required. Twenty-pound fire extinguishers shall be m within 25 feet of, and at each end of, the fuel storage area to ensure adequate protection in the event of a fire.

Leatherleaf Solar and its subcontractors shall maintain the site in a clean, neat and safe condition. As the work progresses, materials, tools, waste materials, rubbish and debris will be removed accordingly. Leatherleaf Solar and its subcontractors will incur all costs of clean-up.

2.7 OPERATION AND MAINTENANCE

2.7.1 EQUIPMENT MAINTENANCE

Once constructed, the project will require very little maintenance. There will be no need to build additional transportation infrastructure or complete public improvements to accommodate traffic as all of our projects are remotely monitored. Electrical engineers will service electrical equipment, primarily the inverters and transformers, on average once per month. Solar PV panels have a very low failure rate (approximately one in 10,000 per year) and are warrantied for twenty-five (25) years.

Leatherleaf Solar will conduct an annual performance audit and inspection to assess the quality of equipment. Some years, we will expect to identify areas within the array area in need of replacement or repair. Module replacement rarely occurs outside of these annual performance inspections and we would expect to perform module replacement less than 10 times over the initial 25-year term. Solar panels are easily replaced from inventory stores and financing to change-out the array at warranty's end has been built into our cost models. Maintenance will likely create 5-9 visits to the site on average per year. Leatherleaf Solar does not anticipate the need for further equipment maintenance than the above.

Please see Exhibit F – Operations and Maintenance Plan for further detail on the maintenance schedule that Cypress Creek Renewables utilizes on all solar energy facilities that we maintain.

2.7.2 VEGETATION MAINTENANCE

Leatherleaf Solar is committed to landscaping best practices that stabilize the soil to add strength and durability for the long-term success of the project and the health of the land. Sustainable management practices and the promotion of healthy biodiversity within local ecosystems are a priority for Leatherleaf Solar.

We will work to employ techniques that are most appropriate for the local environment based on the following factors:

- Runoff prevention
- Carbon sequestration
- Pollination and other insect services
- Air quality concerns
- Invasive species resistance
- Viable wildflower areas
- Rate of fescue growth

The landscape manager for Leatherleaf Solar will make it a priority to minimize the use of mechanical mowing and herbicides. We anticipate mowing will occur at the Leatherleaf Solar site four times during the growing season (April-Oct). In rare circumstances where herbicides are deemed necessary, an effort will be made to minimize use and only apply bio-degradable, PA-registered, organic solutions that are non-toxic to pets and wildlife. Leatherleaf Solar will not use pesticides.

2.7.3 DECOMMISSIONING OF SITE

Leatherleaf Solar guarantees that all operator-owned equipment, conduits, structures, and foundations shall be removed, at the expense of the operator, in the unlikely event that the system ceases power production, or the land lease expires or is terminated. Leatherleaf Solar is contractually obligated through the lease we sign with the Landowner to decommission the project when the need arises. A draft Decommissioning Plan specific to this project has been prepared to meet Town requirements. In addition to the certainty provided by the lease agreement and Decommissioning Plan, another element that ensures decommissioning is the value of the equipment used to develop Leatherleaf Solar. If decommissioning becomes necessary, there will be great incentive to promptly remove all materials for sale and re-use. A Decommissioning Cost Estimate has been prepared for this project.

Please see Exhibits H-1 and H-2—Decommissioning Plan and Decommissioning Cost Estimate for more information.

2.8 SOLAR ENERGY FACILITY SAFETY

Leatherleaf Solar will be a safe facility that will not impact the well-being of local residents or Byron in general. Solar energy facilities provide safe and reliable sources of power, using simple and proven technologies. Further, CCR sources panels from Tier 1 rated manufacturers, the highest rating in the Bloomberg New Energy Finance ranking system.⁹

The project will be constructed according to all required building and electrical codes and safety measures. Site plans will be approved by all applicable local authorities, and regularly visited throughout construction as required by the town or by New York State Building Code. Energized system components, such as inverters, will be commissioned by the manufacturers' technicians.

⁹ Bloomberg New Energy Finance, November 2016. [BNEF PV Module Maker Tiering System](https://data.bloomberglp.com/bnef/sites/4/2012/12/bnef_2012-12-03_PVModuleTiering.pdf).
<https://data.bloomberglp.com/bnef/sites/4/2012/12/bnef_2012-12-03_PVModuleTiering.pdf>
Accessed on February 1,

The project will employ required lock-out measures and safety warnings. A perimeter security fence will prevent trespassing and vandalism. Access codes to the gate will be provided to the Police Department, Fire Department, and emergency service providers. Vehicular access to the site is adequate for the use proposed and for emergency services, as indicated in Exhibit A – Civil Site Plans.

The regular vegetation control methods prevent buildup of debris that could otherwise pose risk of fire material, thus Leatherleaf Solar will pose no increased risk of fires to the surrounding areas.

2.9 TRAFFIC SAFETY

With no more than one to four vehicle visits per quarter on average, the project will not be a significant traffic generator and will not cause undue harm to the surrounding road networks, to local responders, or to the New York Department of Transportation. By contrast, American households generate an average of ~6 vehicle trips per day (over 500/quarter).¹⁰

A temporary rise in vehicle traffic during the construction period is anticipated. However, given the limited number of vehicles visiting the site over the construction period, traffic patterns are not anticipated to be impacted. During the construction period, approximately 10-40 personal cars and 1-12 trucks will visit the site per day.

Upon completion of the facility installation, no more than four (4) vehicles are anticipated to visit the site on a quarterly basis. In sum, no significant traffic impacts are anticipated.

2.10 AGENCY COORDINATION

Leatherleaf Solar will continue to coordinate with all necessary Federal, State, and County agencies and other entities throughout the planning process. Leatherleaf Solar is prepared to work with Genesee County should the Application trigger a County review per New York State General Municipal Law 239m.

This proposal will trigger a State Environmental Quality Review Act (SEQRA) review. Leatherleaf Solar has contracted an environmental consulting firm to perform field investigations, literature reviews, and agency consultations to assess existing environmental conditions at the project site. Information derived from these investigations will be used by Leatherleaf Solar to avoid and minimize impacts to environmental resources during the design process.

Please see Exhibit B for further information on SEQRA concurrences.

¹⁰ U.S. Department of Transportation. Summary of Travel Trends; 2009 National Household Travel Survey. 2009 <<http://nhts.ornl.gov/2009/pub/stt.pdf>>

Agricultural Data Statement

Date 3/18/23

Instructions: This form must be completed for any application for a special use permit, site plan approval, use variance or a subdivision approval requiring municipal review that would occur on property within 500 feet of a farm operation located in a NYS Dept. of Ag & Markets certified Agricultural District.

Applicant**Owner if Different from Applicant**

Name: <u>Cypress Creek Renewables/Leatherleaf Solar LLC</u> Address: <u>PO Box 173</u> <u>Latham NY 12110</u>	Name: <u>Ivison</u> Address: <u>7501 Ivison Road</u>
---	---

1. Type of Application: Special Use Permit; Site Plan Approval ; Use Variance; Subdivision Approval

2. Description of proposed project: Construct a 5MW solar farm on 35 acres on a 179 acre parcel

3. Location of project: Address: 7501 Ivison Road
Tax Map Number (TMP) 9.-1-7.113

4. Is this parcel within an Agricultural District? NO YES (Check with your local assessor if

5. If YES, Agricultural District Number _____ you do not know)

6. Is this parcel actively farmed? NO YES

7. List all farm operations within 500 feet of your parcel. Attach additional sheets if necessary.

Name: <u>Homer Ivison</u> Address: <u>7410 Ivison Road tax id 9.-1-9</u> Is this parcel actively farmed? NO <input checked="" type="checkbox"/> YES	Name: <u>Dean Ivison</u> Address: <u>tax id 9.-1-8.1</u> Is this parcel actively farmed? NO <input checked="" type="checkbox"/> YES
Name: <u>David Kent</u> Address: <u>tax id 9.-2-39.11</u> Is this parcel actively farmed? NO <input checked="" type="checkbox"/> YES	Name: <u>Josh Kent</u> Address: <u>tax id 9.-2-62</u> Is this parcel actively farmed? NO <input checked="" type="checkbox"/> YES

Signature of Applicant

Signature of Owner (if other than applicant)

Reviewed by: Melissa Verlan
Signature of Municipal Official

3/29/23
Date

NOTE TO REFERRAL AGENCY: County Planning Board review is required. A copy of the Agricultural Data Statement must be submitted along with the referral to the County Planning Department.

T-04-BYR-04-23



© All EagleView Technology Corporation

1. Exhibits

EXHIBIT A. CIVIL SITE PLANS

SITE PLAN REVIEW DRAWINGS FOR **LEATHERLEAF SOLAR, LLC** TOWN OF BYRON GENESSEE COUNTY, NEW YORK

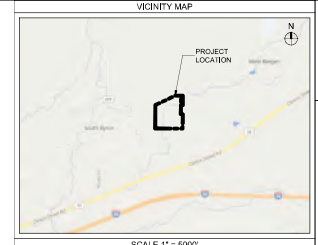

SITE DATA		
FILE: 14-2-113	PROPERTY OWNER: ORAN MESH	SITE ADDRESS: 7501 IVISON ROAD, BYRON, NY 14422
TOWN OF BYRON	ZONE: AGRICULTURAL-RESIDENTIAL	

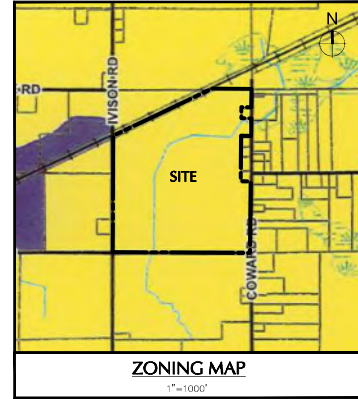

DRAWING LIST	
DRAWING NO.	DRAWING TITLE
C-100	TITLE SHEET
C-150	EXISTING SITE CONDITIONS & REMOVAL PLAN
C-200	SITE LAYOUT & MATERIALS PLAN
C-300	GRADING & DRAINAGE PLAN
C-400	EROSION & SEDIMENT CONTROL PLAN
C-401	PHASING PLAN
C-500	DETAILS (1 OF 2)
C-501	DETAILS (2 OF 2)
L-100	PLANTING PLAN
L-500	PLANTING DETAILS & NOTES

SITE INFORMATION	
ADDRESS:	7501 IVISON ROAD BYRON, NY 14422
TAX ID:	9-1-7.113
ACREAGE:	179.872 ACRES
ZONE:	AGRICULTURAL-RESIDENTIAL (R-A)

APPLICANT	
LEATHERLEAF SOLAR, LLC P.O. BOX 173 LATHAM, NY 12110	TELEPHONE: 203-558-5602 CONTACT: NICK HAWVERMALE

CIVIL ENGINEER AND LANDSCAPE ARCHITECT	
LANGAN ENGINEERING, ENVIRONMENTAL, SURVEYING, LANDSCAPE ARCHITECTURE AND GEOLOGY, D.P.C. ONE NORTH BROADWAY, SUITE 910 WHITE PLAINS, NY 10604	TELEPHONE: 914-323-7400 CONTACT: CHRISTINA M. ZOLEZI, PE

SURVEY	
LAWSON SURVEYING & MAPPING 8546 STATE HIGHWAY 7, SUITE 1 P.O. BOX 1098 ONEONTA, NY 13820	TELEPHONE: 607-432-3300 CONTACT: ROBERT J. LAWSON, LS

LANGAN
LANDSCAPE ARCHITECTURE AND DESIGN, D.P.C.
One North Broadway, Suite 910
White Plains, NY 10601
www.langan.com
T: 914-323-7400 F: 914-323-7401

LEATHERLEAF SOLAR, LLC
7501 IVISON ROAD
TOWN OF BYRON, NY 14422
GENESSEE COUNTY

DATE: 02/24/2023
DRAWN BY: R
CHECKED BY: R
TITLE SHEET
C-100

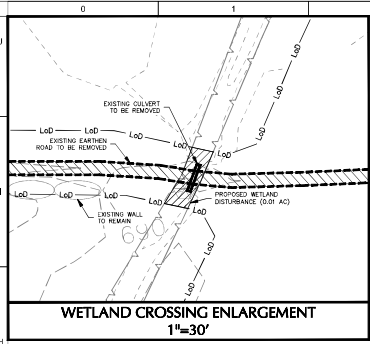
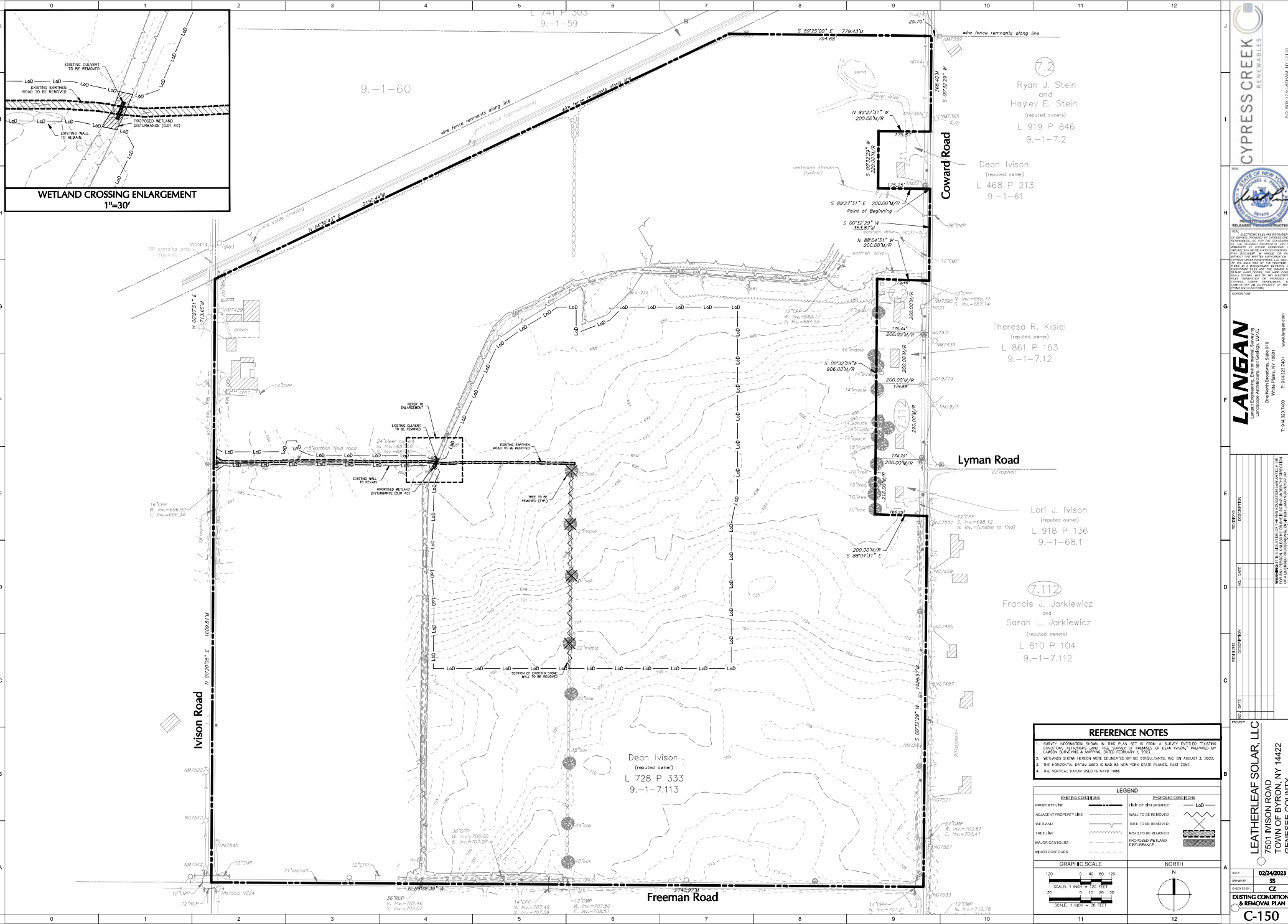

REFERENCE NOTES

- SURVEY INFORMATION SHOWN IN THIS PLAN SET IS FROM A SURVEY ENTITLED "EXISTING CONDITIONS ALIQUOTING LAND: THE COUNTY OF FRANKLIN, STATE OF NEW YORK," PREPARED BY LANGAN SURVEYING & MAPPING, DATED FEBRUARY 1, 2023.
- WETLANDS SHOWN HEREON WERE DELINEATED BY SEI CONSULTANTS, INC. ON AUGUST 3, 2022.
- THE HORIZONTAL DATUM USED IS NAAD AS NEW YORK STATE PLANE, EAST ZONE.
- THE VERTICAL DATUM USED IS NAVD 88.

LEGEND

EXISTING CONDITIONS	PROPOSED CONDITIONS
PROPERTY LINE	LIMIT OF DISTURBANCE
ADJACENT PROPERTY LINE	WALL TO BE REMOVED
WETLAND	TREE TO BE REMOVED
ROAD TO BE REMOVED	PROPOSED WETLAND DISTURBANCE
MAJOR CONTOURS	
MINOR CONTOURS	

GRAPHIC SCALE

SCALE: 1" = 100 FEET
SCALE: 1" = 30 FEET

NORTH

CYPRESS CREEK RENEWABLES

STATE OF NEW YORK
DEPARTMENT OF ENVIRONMENTAL CONSERVATION

LANGAN SURVEYING & MAPPING, INC.
Landscape Architecture and Geology, LLC
One North Broadway, Suite 910
White Plains, NY 10611
www.langan.com
T: 914-423-7400 F: 914-423-7401

LEATHERLEAF SOLAR, LLC
7501 IVISON ROAD
TOWN OF BYRON, NY 14422
GENESEE COUNTY

DATE: 02/24/2023
DRAWN BY: [Signature]
CHECKED BY: [Signature]

EXISTING CONDITIONS & REMOVAL PLAN

C-150

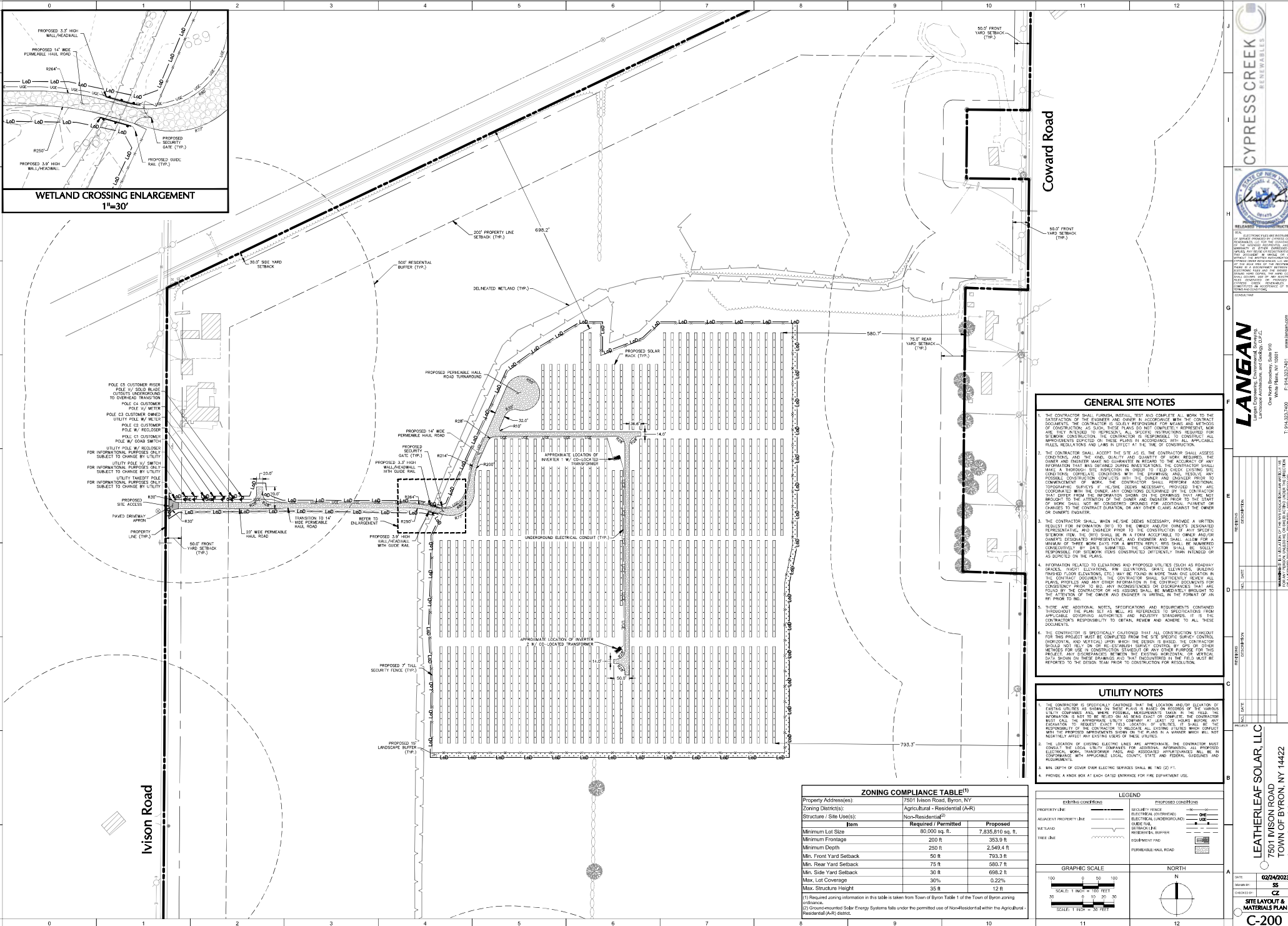

GENERAL SITE NOTES

- THE CONTRACTOR SHALL FURNISH MATERIAL, TEST AND COMPLETE ALL WORK TO THE SATISFACTION OF THE ENGINEER AND OWNER IN ACCORDANCE WITH THE CONTRACT DOCUMENTS. THE CONTRACTOR IS SOLELY RESPONSIBLE FOR MEANS AND METHODS OF CONSTRUCTION AS SUCH. THESE PLANS DO NOT COMPLETELY REPRESENT NOR ARE THEY INTENDED TO REPRESENT ALL REQUIRED CONSTRUCTION DETAILS. THE CONTRACTOR SHALL BE RESPONSIBLE FOR OBTAINING ALL NECESSARY PERMITS AND APPROVALS REQUIRED FOR CONSTRUCTION. THE CONTRACTOR IS RESPONSIBLE TO CONTROL ALL IMPROVEMENTS SPECIFIED ON THESE PLANS IN ACCORDANCE WITH ALL APPLICABLE REGULATIONS AND LAWS IN EFFECT AT THE TIME OF CONSTRUCTION.
- THE CONTRACTOR SHALL ACCEPT THE SITE AS IS. THE CONTRACTOR SHALL VERIFY CONDITIONS AND THE KIND, QUALITY AND QUANTITY OF WORK REQUIRED. THE OWNER AND ENGINEER SHALL NOT GUARANTEE OR WARRANT TO THE CONTRACTOR ANY INFORMATION CONCERNING THE ACCURACY, COMPLETENESS, OR REASONABLENESS OF THE DATA, RECORDS, OR INFORMATION PROVIDED BY THE OWNER AND ENGINEER. THE CONTRACTOR SHALL VERIFY ALL INFORMATION BEFORE COMMENCING CONSTRUCTION. THE CONTRACTOR SHALL BE RESPONSIBLE FOR OBTAINING ALL NECESSARY PERMITS AND APPROVALS REQUIRED FOR CONSTRUCTION. THE CONTRACTOR IS RESPONSIBLE TO CONTROL ALL IMPROVEMENTS SPECIFIED ON THESE PLANS IN ACCORDANCE WITH ALL APPLICABLE REGULATIONS AND LAWS IN EFFECT AT THE TIME OF CONSTRUCTION.
- THE CONTRACTOR SHALL, WHEN HE DEEMS NECESSARY, PROVIDE A WRITTEN REPORT FOR INFORMATION TO THE OWNER AND ENGINEER. THE REPORT SHALL BE SUBMITTED TO THE OWNER AND ENGINEER PRIOR TO THE START OF ANY WORK. THE REPORT SHALL BE SUBMITTED TO THE OWNER AND ENGINEER PRIOR TO THE START OF ANY WORK. THE REPORT SHALL BE SUBMITTED TO THE OWNER AND ENGINEER PRIOR TO THE START OF ANY WORK.
- INFORMATION RELATED TO ELEVATIONS AND PROPOSED UTILITIES (SUCH AS ROADWAY GRADES, INVERT ELEVATIONS, R/W ELEVATIONS, GRADE ELEVATIONS, BUILDING FINISHED FLOOR ELEVATIONS, ETC.) MAY BE FOUND IN MORE THAN ONE LOCATION IN THE CONTRACT DOCUMENTS. THE CONTRACTOR SHALL SUFFICIENTLY REVIEW ALL PLANS, SPECIFICATIONS, AND ANY OTHER DOCUMENTS IN THE CONTRACT DOCUMENTS FOR CONFLICTS PRIOR TO CONSTRUCTION. THE CONTRACTOR SHALL BE RESPONSIBLE FOR BRINGING TO THE ATTENTION OF THE OWNER AND ENGINEER PRIOR TO THE START OF ANY WORK ANY CONFLICTS THAT ARE FOUND IN THESE DOCUMENTS. THE CONTRACTOR'S FAILURE TO DO SO SHALL BE DEEMED CONCLUSIVE AND THE CONTRACTOR SHALL BE RESPONSIBLE FOR ANY CONFLICTS THAT ARE ENCOUNTERED IN THE FIELD OR AS SHOWN ON THE PLANS.
- THESE ARE ADDITIONAL NOTES, SPECIFICATIONS AND REQUIREMENTS CONTAINED THROUGHOUT THE PLANS. SUCH AS REFERENCED TO SPECIFICATIONS FROM THE APPLICABLE REGULATIONS. THE CONTRACTOR SHALL BE RESPONSIBLE TO OBTAIN, REVIEW AND ADHERE TO ALL THESE DOCUMENTS.
- THE CONTRACTOR IS SPECIFICALLY CAUTIONED THAT ALL CONSTRUCTION STAKEOUT FOR THIS PROJECT MUST BE COMPLETED FROM THE SITE SPECIFIC SURVEY CONTROL (BENCHMARK, AND NATURAL CORNERS) WHICH THE DESIGN IS BASED. THE CONTRACTOR SHALL BE RESPONSIBLE FOR OBTAINING ALL NECESSARY PERMITS AND APPROVALS REQUIRED FOR CONSTRUCTION. THE CONTRACTOR IS RESPONSIBLE TO CONTROL ALL IMPROVEMENTS SPECIFIED ON THESE PLANS IN ACCORDANCE WITH ALL APPLICABLE REGULATIONS AND LAWS IN EFFECT AT THE TIME OF CONSTRUCTION.

UTILITY NOTES

- THE CONTRACTOR IS SPECIFICALLY CAUTIONED THAT THE LOCATION AND DEPTH OF EXISTING UTILITIES AS SHOWN ON THESE PLANS IS BASED ON RECORDS OF THE VARIOUS UTILITY COMPANIES AND, WHERE FEASIBLE, RECORDING TAPES. THE CONTRACTOR SHALL VERIFY THE ACCURACY OF ALL RECORDS BY CONDUCTING A FIELD SURVEY PRIOR TO CONSTRUCTION. THE CONTRACTOR SHALL BE RESPONSIBLE FOR BRINGING TO THE ATTENTION OF THE OWNER AND ENGINEER PRIOR TO THE START OF ANY WORK ANY CONFLICTS THAT ARE FOUND IN THESE DOCUMENTS. THE CONTRACTOR'S FAILURE TO DO SO SHALL BE DEEMED CONCLUSIVE AND THE CONTRACTOR SHALL BE RESPONSIBLE FOR ANY CONFLICTS THAT ARE ENCOUNTERED IN THE FIELD OR AS SHOWN ON THE PLANS.
- THE LOCATION OF EXISTING UTILITY LINES AND APPROPRIATELY, THE CONTRACTOR MUST CONSULT THE LOCAL UTILITY COMPANIES FOR ADDITIONAL INFORMATION. ALL NECESSARY ELECTRICAL, PIPING, TRANSFORMER PADS AND APPROPRIATE APPROVALS SHALL BE OBTAINED PRIOR TO CONSTRUCTION.
- A MINIMUM DEPTH OF COVER OVER ALL UTILITIES SHALL BE TWO (2) FT.
- PROVIDE A 30" ROCK AT EACH-GATED ENTRANCE FOR FIRE DEPARTMENT USE.

Property Address(es)	7501 Iverson Road, Byron, NY (Zoning District(s): Agricultural - Residential (A-R))		
Structure / Site Use(s)	Non-Residential ⁽²⁾		
Item	Required	Permitted	Proposed
Minimum Lot Size	80,000 sq. ft.	7,835,810 sq. ft.	7,835,810 sq. ft.
Minimum Frontage	200 ft.	353.9 ft.	353.9 ft.
Minimum Depth	250 ft.	2,549.4 ft.	2,549.4 ft.
Min. Front Yard Setback	50 ft.	793.3 ft.	793.3 ft.
Min. Rear Yard Setback	75 ft.	885.0 ft.	885.0 ft.
Min. Side Yard Setback	30 ft.	688.2 ft.	688.2 ft.
Max. Lot Coverage	30%	0.22%	0.22%
Max. Structure Height	35 ft.	12 ft.	12 ft.

(1) Required zoning information in this table is taken from Town of Byron Table 1 of the Town of Byron zoning ordinance.
 (2) Ground-mounted Solar Energy Systems falls under the permitted use of Non-Residential within the Agricultural - Residential (A-R) district.

LEGEND

EXISTING CONDITIONS	PROPOSED CONDITIONS
PROPERTY LINE	SECURITY FENCE
ADJACENT PROPERTY LINE	ELECTRICAL (OVERGROUND)
SETBACK LINE	SETBACK LINE
WETLAND	EQUIPMENT PAD
UTILITY LINE	PERMEABLE HALL ROAD

GRAPHIC SCALE

1" = 20 FT
 1" = 10 FT

NORTH

DATE: **02/24/2023**

PROJECT: **LEATHERLEAF SOLAR, LLC**

7501 IVerson ROAD
 TOWN OF BYRON, NY 14422

GENESEE COUNTY

SITELAYOUT & MATERIALS PLAN

C-200

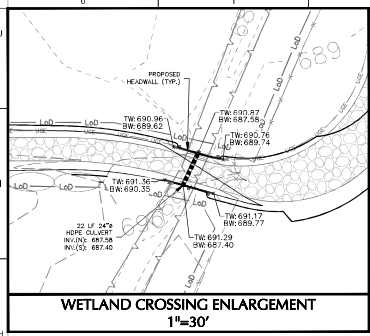
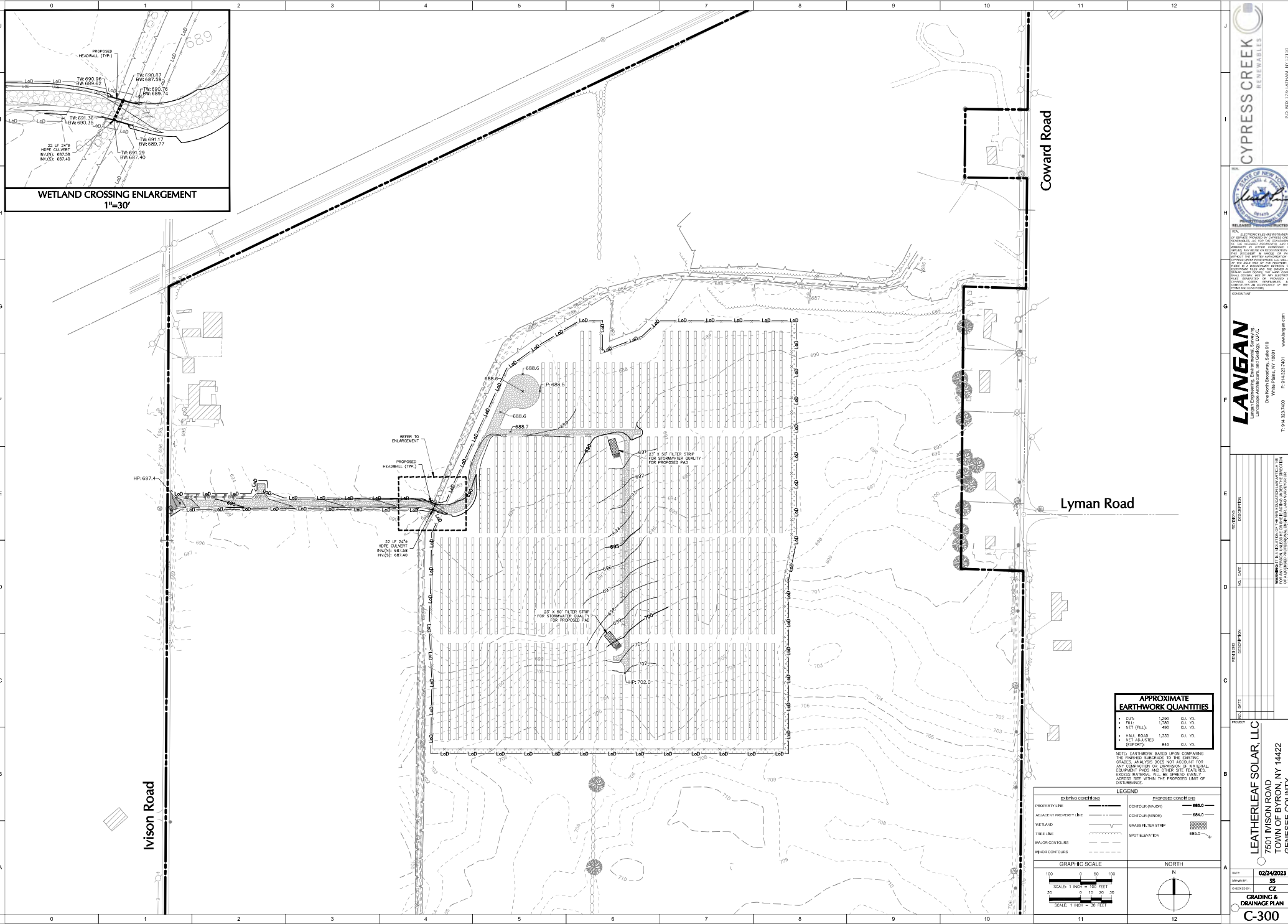

APPROXIMATE EARTHWORK QUANTITIES

• CUT	1,290	CU. YD.
• FILL	1,780	CU. YD.
• NET FILL	490	CU. YD.
• HAUL ROAD	1,150	CU. YD.
• NET IMPORTS	840	CU. YD.

NOTE: EARTHWORK BASED UPON COMPARING THE FINISHED SURFACE TO THE LOWEST GRADE AVAILABLE. DOES NOT ACCOUNT FOR ANY COMPACTION OR LOOSENING OF MATERIAL. EQUIPMENT SIZES AND TOWER SITE FEATURES. EXCESS MATERIAL WILL BE SPREAD EVENLY ACROSS SITE WITHIN THE PROPOSED LIMIT OF DISTURBANCE.

LEGEND

EXISTING CONDITIONS	PROPOSED CONDITIONS
PROPERTY LINE	CONTOUR (RANKING) 685.0
ADJACENT PROPERTY LINE	CONTOUR (RANKING) 684.0
WETLAND	GRASS FILTER STRIP
TREE LINE	SPOT ELEVATION 685.0
MAJOR CONTOURS	
MINOR CONTOURS	

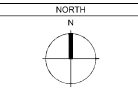
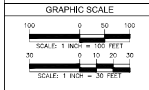

NO.	DATE	DESCRIPTION



PHASE 1
4.0 ACRES

PHASE 7
4.8 ACRES

PHASE 8
3.0 ACRES

PHASE 6
5.0 ACRES

PHASE 4
4.5 ACRES

PHASE 5
3.8 ACRES

PHASE 2
5.0 ACRES

PHASE 3
4.9 ACRES

PHASE #	AREA	1	2	3	4	5	6	7	8	9	10	11	12
1	CL, ESC, FNC, GR, LD, RD, RFP, RM, RST, SFP, SOL, TS												
2	CL, ESC, FNC, GR, LD, RD, RFP, RM, RST, SFP, SOL, TS												
3	CL, ESC, FNC, GR, LD, RD, RFP, RM, RST, SFP, SOL, TS												
4	CL, ESC, FNC, GR, LD, RD, RFP, RM, RST, SFP, SOL, TS												
5	CL, ESC, FNC, GR, LD, RD, RFP, RM, RST, SFP, SOL, TS												
6	CL, ESC, FNC, GR, LD, RD, RFP, RM, RST, SFP, SOL, TS												
7	CL, ESC, FNC, GR, LD, RD, RFP, RM, RST, SFP, SOL, TS												
8	CL, ESC, FNC, GR, LD, RD, RFP, RM, RST, SFP, SOL, TS												
FINAL													

CONSTRUCTION SEQUENCE KEY

- CL COMPLETE TREE REMOVAL AND STUMPING.
- ESC INSTALL EROSION AND SEDIMENT CONTROL PRACTICES.
- FNC INSTALL FENCE.
- GR SITE GRADING.
- LD REMOVE TEMPORARY LAYDOWN AREA. STABILIZE THE DISTURBED AREA.
- RD CONSTRUCT ACCESS ROAD, TEMPORARY LAYDOWN AREA, AND/OR INVERTER PADS.
- RFP COMPLETE SITE RESTORATION OVER PERMEABLE HAUL ROAD AND FINALIZE INSTALLATION.
- RM REMOVE TEMPORARY EROSION AND SEDIMENT CONTROL PRACTICES. STABILIZE THE DISTURBED AREA.
- RST COMPLETE SITE RESTORATION. APPLY SEED AND MULCH.
- SFP INSTALL GRASS FILTER STRIP.
- SOL INSTALL SOLAR PANELS.
- TS APPLY TEMPORARY SEED AND MULCH.

LEGEND

EXISTING CONDITIONS: PROPERTY LINE, ADJACENT PROPERTY LINE, BOUNDARY, TREE LINE

PROPOSED CONDITIONS: PHASE LINE

GRAPHIC SCALE
100 0 50 100
SCALE: 1" = 100' FEET

NORTH
N

CONSTRUCTION SEQUENCE

PHASE #	AREA	1	2	3	4	5	6	7	8	9	10	11	12
1	CL, ESC, FNC, GR, LD, RD, RFP, RM, RST, SFP, SOL, TS												
2	CL, ESC, FNC, GR, LD, RD, RFP, RM, RST, SFP, SOL, TS												
3	CL, ESC, FNC, GR, LD, RD, RFP, RM, RST, SFP, SOL, TS												
4	CL, ESC, FNC, GR, LD, RD, RFP, RM, RST, SFP, SOL, TS												
5	CL, ESC, FNC, GR, LD, RD, RFP, RM, RST, SFP, SOL, TS												
6	CL, ESC, FNC, GR, LD, RD, RFP, RM, RST, SFP, SOL, TS												
7	CL, ESC, FNC, GR, LD, RD, RFP, RM, RST, SFP, SOL, TS												
8	CL, ESC, FNC, GR, LD, RD, RFP, RM, RST, SFP, SOL, TS												
FINAL													

CYPRESS CREEK RENEWABLES
P.O. BOX 175 LATHAM, NY 13110

STATE OF NEW YORK
DEPARTMENT OF ENVIRONMENTAL CONSERVATION
DIVISION OF EROSION CONTROL AND SEDIMENTATION
100 N. ZEEB ROAD, ALBANY, NY 12242-1200
TEL: 518-485-2700 FAX: 518-485-2701

LANGAN
LANGAN ENGINEERING, ARCHITECTURE AND DESIGN, LLC
One North Broadway, Suite 910
White Plains, NY 10601
T: 914-523-7400 F: 914-523-7401 www.langan.com

LEATHERLEAF SOLAR, LLC
7501 IVISON ROAD
TOWN OF BYRON, NY 14422
GENESEE COUNTY

DATE: 02/24/2023
DRAWN BY: R
CHECKED BY: R
PHASING PLAN
C-401

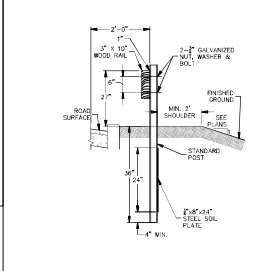

NOTES:

1. GUIDE RAIL SHALL MEET ALL REQUIREMENTS OF THE LATEST EDITION OF THE NYSDOT STANDARD SPECIFICATIONS FOR CONSTRUCTION MATERIALS SECTION 703.05.
2. THE OFFSET TO THE GUIDE RAIL SHALL BE MEASURED FROM FACE OF CURB TO FACE OF GUIDE RAIL. THE RAIL HEIGHT MEASUREMENT SHALL BE TO THE TOP SURFACE OF CURB HEIGHT OR SPEED SHALL BE MEASURED FROM THE SURFACE OF THE ROAD WITH THE OFFSET IS GREATER THAN 1'-0".

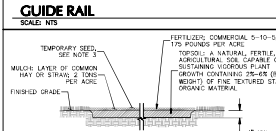

NOTES:

1. TOPSOIL USE ON DISTURBED SOIL AREAS THAT WILL BE LEFT OPENED TOP.
2. TOPSOIL OR ORGANIC MAT. WILL BE APPLIED DURING CONSTRUCTION.
3. SEED MIX:
 - A. IF SPRING, SUMMER OR EARLY FALL SEED WITH ANNUAL OR PERENNIAL VEGETABLES AT A RATE OF 1 LB PER 1000 SQ FT.
 - B. IF LATE FALL OR WINTER SEED WITH COVERED "PROTECTOR" WATER (CELESTAL) AT A RATE OF 2.5 LBS PER 1000 SQ FT.

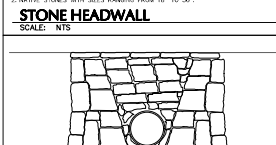
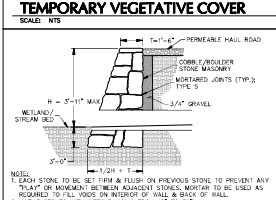

NOTES:

1. SEE STONE HEADWALL DETAIL FOR ADDITIONAL INFORMATION.

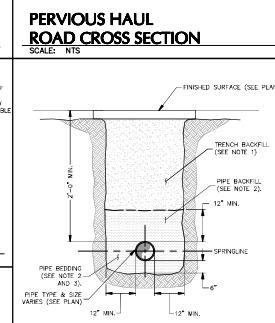
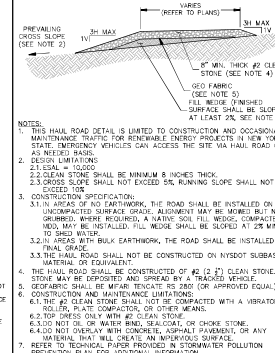

NOTES:

1. PREVIOUSLY GRANULAR FILL MATERIAL, MAX. PARTICLE SIZE 4".
2. Mixture of crushed stone and gravel, free of soft, non-durable particles, organic materials and compressed particles. MIN. PARTICLE SIZE: 4".
3. Mixture of crushed stone and gravel, free of soft, non-durable particles, organic materials and compressed particles. MIN. PARTICLE SIZE: 4".
4. Mixture of crushed stone and gravel, free of soft, non-durable particles, organic materials and compressed particles. MIN. PARTICLE SIZE: 4".

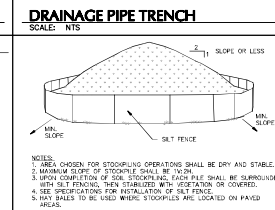

NOTES:

1. SEE SPECIFICATIONS FOR INSTALLATION OF SILT FENCE.
2. SIFT SCREENS TO BE USED WHERE STOCKPILES ARE LOCATED ON FRAGILE AREAS.

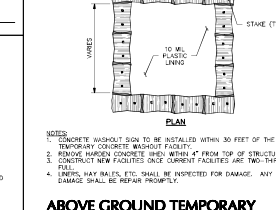
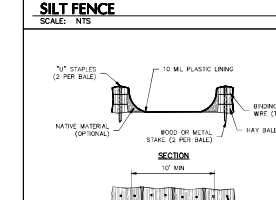
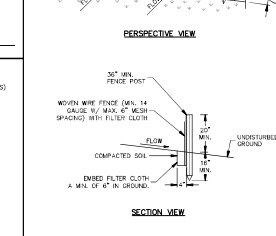
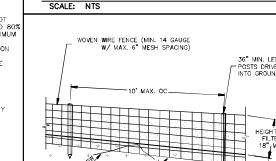
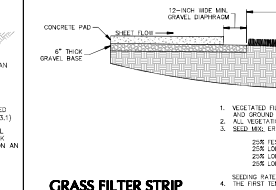

NOTES:

1. CONCRETE WASHOUT FACILITY TO BE INSTALLED WITHIN 30 FEET OF THE TEMPORARY CONCRETE WASHOUT FACILITY.
2. REMOVE WASHOUT CONCRETE OPEN WITHIN 4" FROM TOP OF STRUCTURE.
3. CONCRETE NEW FACILITIES ONLY CURRENT FACILITIES ARE TWO INCHES THICKNESS.
4. REPAIRS, HAY RATES, ETC. SHALL BE INSPECTED FOR DAMAGE. ANY DAMAGE SHALL BE REPAIR PROMPTLY.

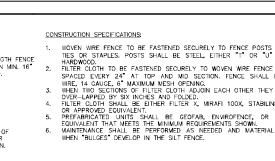
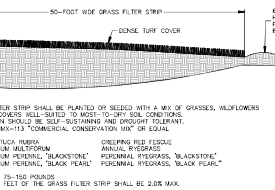

CONSTRUCTION SPECIFICATIONS

1. 60EN WIRE FENCE TO BE FASTENED SECURELY TO FENCE POSTS WITH WIRE TIES OR STAPLES. POSTS SHALL BE STEEL EITHER "T" OR "J" TYPE OR APPROVED.
2. FILTER CLOTH TO BE FASTENED SECURELY TO WIRE WIRE FENCE WITH TIES OR STAPLES. EXIST AT 10' FROM END AND SECTION FENCE SHALL BE WORN WITH 12' GRASS. 12' MINIMUM BEHIND GRASS.
3. WHEN TWO SECTIONS OF FILTER CLOTH ADJOIN EACH OTHER THEY SHALL BE OVERLAPPED BY 12" MINIMUM.
4. FILTER CLOTH SHALL BE BURIED UNDER 12" MINIMUM STAPLER TYPED OR APPROVED EQUIPMENT.
5. BURIED UNDER 12" MINIMUM STAPLER TYPED OR APPROVED EQUIPMENT THAT MEETS THE MINIMUM REQUIREMENTS SPECIFIED.
6. MAINTENANCE SHALL BE PERFORMED AS NECESSARY AND MATERIAL REMOVED WHEN "BULGES" DEVELOP IN THE SILT FENCE.

DETAIL NOTES

1. INSTALLATION SHALL BE DONE IN ACCORDANCE WITH THE NEW YORK STATE ENGINEERING AND PROFESSIONAL ARCHITECTS BOARD STANDARD SPECIFICATIONS FOR CONSTRUCTION MATERIALS SECTION 703.05.
2. ALL SILT FENCE SHALL BE PLACED AS CLOSE TO THE DISTURBED AREA AS POSSIBLE, BUT AT LEAST 10' FROM THE TOP OF ANY DIRT BANKS THAT MAY BEHIND TO ALLOW FOR MAINTENANCE AND ROLL DOWN THE AREA.
3. THE TYPE OF SILT FENCE SPECIFIED FOR EACH LOCATION ON THE PLAN SHALL BE INDICATED BY THE NUMBER OF THE TABLE BELOW. IF A TYPE SILT FENCE IS NOT SPECIFIED ON THE PLAN, IT IS INTENDED FOR STANDARD SILT FENCE CAN BE APPLIED.
4. SILT FENCE SHALL BE REMOVED AS SOON AS THE DISTURBED AREA HAS ACHIEVED FINAL STABILIZATION.

SLOPE	STEEPNESS	SLOPE LENGTH	FENCE LENGTH (FT)	STANDARD	REINFORCED	SUPER
<2%	<6:1	300/1000	N/A	N/A		
2-10%	10:1 TO 12:1	125/1000	250/2000	300/2500		
10-20%	10:1 TO 5:1	100/750	150/1000	200/1000		
20-33%	5:1 TO 3:1	60/500	80/750	100/1000		
33-50%	3:1 TO 2:1	40/250	70/350	100/500		
>50%	>2:1	20/125	30/175	50/250		

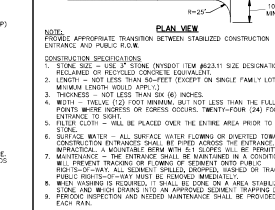
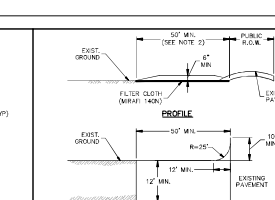

CONSTRUCTION SPECIFICATIONS

1. STONE SIZE TO USE: 2" STONE (WITHOUT FIRM REGISTRY SIZE DESIGNATION #), OR EQUIVALENT OF FIELD-ORIGIN EQUIVALENT.
2. LENGTH - NOT LESS THAN 90-FEET (EXCEPT ON SINGLE FAMILY LOT, 30-FEET MINIMUM WIDTH PERMIT).
3. THICKNESS - NOT LESS THAN 6" (6" MINIMUM).
4. WORK THRESHOLD 200 MINIMUM, BUT NOT LESS THAN THE FULL WIDTH AT POINTS WHERE INGRESS OR EGRESS OCCURS. TWENTY-FOUR (24) FOOT IF SINGLE ENTRANCE TO SITE.
5. FILTER CLOTH - WILL BE PLACED OVER THE ENTIRE AREA PRIOR TO PLACING OF STABILIZER MIXTURE - ALL SURFACE MIXTURES TURNING OR DEFLECTED TOWARD CONSTRUCTION ENTRANCES SHALL BE STOPPED BY THE ENTRANCE IF FENCING IS IMPROPERLY MAINTAINED. EXISTENCE OF A FENCING WILL BE MAINTAINED.
6. MAINTENANCE - THE ENTRANCE SHALL BE MAINTAINED IN A CONDITION WHICH WILL PREVENT TRACKS OR CLUMPS OF SEDIMENT BEHIND EACH RAIL.
7. RIGHTS-OF-WAY - ALL SEDIMENT SPILLS, DEPOSITS, WASHED OR TRACKED INTO RIGHTS-OF-WAY MUST BE REMOVED IMMEDIATELY.
8. WEED GROWTH - WEEDS SHALL BE REMOVED FROM AREAS STABILIZED WITH STONE AND WHICH BEHIND TO AN APPROVED SOILING TRAPPING DEVICE.
9. FENCING REPAIR AND NEEDED MAINTENANCE SHALL BE REPAIRED AFTER EACH RAIN.

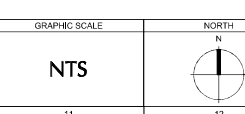

CYPRESS CREEK RENEWABLES

RELEASED PERmits/CONTRACT

STATE OF NEW YORK
DEPARTMENT OF ENVIRONMENTAL CONSERVATION
DIVISION OF EROSION CONTROL
160 W. WASHINGTON ST., SUITE 100
ALBANY, NY 12242
PHONE: (518) 485-2300
WWW.DEC.STATE.NY.US

LANGAN
ENGINEERING

One North Broadway, Suite 910
Byron, NY 14422
Phone: (315) 325-7600 Fax: (315) 325-7601
www.langan.com

DATE: 02/24/2023
DRAWN BY: R
CHECKED BY: R
DETAILS (1 OF 2)
C-500

LEATHERLEAF SOLAR, LLC
7501 WILSON ROAD
TOWN OF BYRON, NY 14422
GENESEE COUNTY

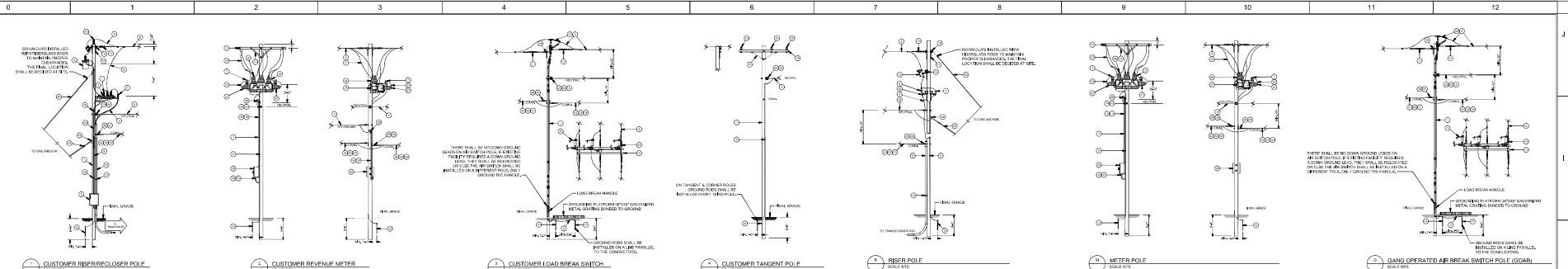

POLE LINE DETAIL MATERIAL LIST

NO.	QTY.	DESCRIPTION
1	1	1/2" DIA. GALV. STEEL
2	1	1/2" DIA. GALV. STEEL
3	1	1/2" DIA. GALV. STEEL
4	1	1/2" DIA. GALV. STEEL
5	1	1/2" DIA. GALV. STEEL
6	1	1/2" DIA. GALV. STEEL
7	1	1/2" DIA. GALV. STEEL
8	1	1/2" DIA. GALV. STEEL
9	1	1/2" DIA. GALV. STEEL
10	1	1/2" DIA. GALV. STEEL
11	1	1/2" DIA. GALV. STEEL
12	1	1/2" DIA. GALV. STEEL
13	1	1/2" DIA. GALV. STEEL
14	1	1/2" DIA. GALV. STEEL
15	1	1/2" DIA. GALV. STEEL
16	1	1/2" DIA. GALV. STEEL
17	1	1/2" DIA. GALV. STEEL
18	1	1/2" DIA. GALV. STEEL
19	1	1/2" DIA. GALV. STEEL
20	1	1/2" DIA. GALV. STEEL
21	1	1/2" DIA. GALV. STEEL
22	1	1/2" DIA. GALV. STEEL
23	1	1/2" DIA. GALV. STEEL
24	1	1/2" DIA. GALV. STEEL
25	1	1/2" DIA. GALV. STEEL
26	1	1/2" DIA. GALV. STEEL
27	1	1/2" DIA. GALV. STEEL
28	1	1/2" DIA. GALV. STEEL
29	1	1/2" DIA. GALV. STEEL
30	1	1/2" DIA. GALV. STEEL
31	1	1/2" DIA. GALV. STEEL
32	1	1/2" DIA. GALV. STEEL
33	1	1/2" DIA. GALV. STEEL
34	1	1/2" DIA. GALV. STEEL
35	1	1/2" DIA. GALV. STEEL
36	1	1/2" DIA. GALV. STEEL
37	1	1/2" DIA. GALV. STEEL
38	1	1/2" DIA. GALV. STEEL
39	1	1/2" DIA. GALV. STEEL
40	1	1/2" DIA. GALV. STEEL
41	1	1/2" DIA. GALV. STEEL
42	1	1/2" DIA. GALV. STEEL
43	1	1/2" DIA. GALV. STEEL
44	1	1/2" DIA. GALV. STEEL
45	1	1/2" DIA. GALV. STEEL
46	1	1/2" DIA. GALV. STEEL
47	1	1/2" DIA. GALV. STEEL
48	1	1/2" DIA. GALV. STEEL
49	1	1/2" DIA. GALV. STEEL
50	1	1/2" DIA. GALV. STEEL

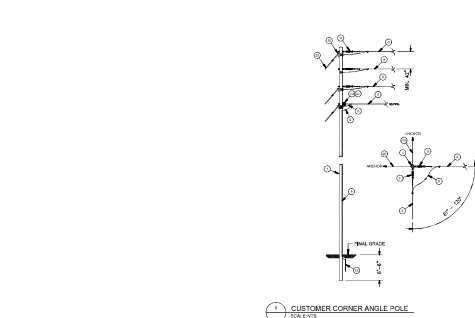
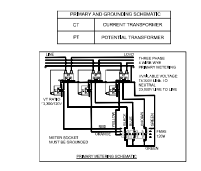

POLE LINE DETAIL MATERIAL LIST

NO.	QTY.	DESCRIPTION
1	1	1/2" DIA. GALV. STEEL
2	1	1/2" DIA. GALV. STEEL
3	1	1/2" DIA. GALV. STEEL
4	1	1/2" DIA. GALV. STEEL
5	1	1/2" DIA. GALV. STEEL
6	1	1/2" DIA. GALV. STEEL
7	1	1/2" DIA. GALV. STEEL
8	1	1/2" DIA. GALV. STEEL
9	1	1/2" DIA. GALV. STEEL
10	1	1/2" DIA. GALV. STEEL
11	1	1/2" DIA. GALV. STEEL
12	1	1/2" DIA. GALV. STEEL
13	1	1/2" DIA. GALV. STEEL
14	1	1/2" DIA. GALV. STEEL
15	1	1/2" DIA. GALV. STEEL
16	1	1/2" DIA. GALV. STEEL
17	1	1/2" DIA. GALV. STEEL
18	1	1/2" DIA. GALV. STEEL
19	1	1/2" DIA. GALV. STEEL
20	1	1/2" DIA. GALV. STEEL
21	1	1/2" DIA. GALV. STEEL
22	1	1/2" DIA. GALV. STEEL
23	1	1/2" DIA. GALV. STEEL
24	1	1/2" DIA. GALV. STEEL
25	1	1/2" DIA. GALV. STEEL
26	1	1/2" DIA. GALV. STEEL
27	1	1/2" DIA. GALV. STEEL
28	1	1/2" DIA. GALV. STEEL
29	1	1/2" DIA. GALV. STEEL
30	1	1/2" DIA. GALV. STEEL
31	1	1/2" DIA. GALV. STEEL
32	1	1/2" DIA. GALV. STEEL
33	1	1/2" DIA. GALV. STEEL
34	1	1/2" DIA. GALV. STEEL
35	1	1/2" DIA. GALV. STEEL
36	1	1/2" DIA. GALV. STEEL
37	1	1/2" DIA. GALV. STEEL
38	1	1/2" DIA. GALV. STEEL
39	1	1/2" DIA. GALV. STEEL
40	1	1/2" DIA. GALV. STEEL
41	1	1/2" DIA. GALV. STEEL
42	1	1/2" DIA. GALV. STEEL
43	1	1/2" DIA. GALV. STEEL
44	1	1/2" DIA. GALV. STEEL
45	1	1/2" DIA. GALV. STEEL
46	1	1/2" DIA. GALV. STEEL
47	1	1/2" DIA. GALV. STEEL
48	1	1/2" DIA. GALV. STEEL
49	1	1/2" DIA. GALV. STEEL
50	1	1/2" DIA. GALV. STEEL

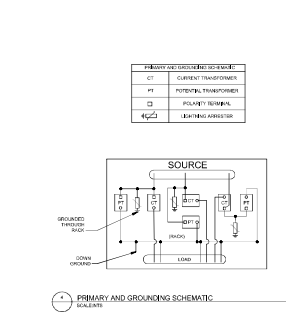

NOTES:

- ALL POLES ARE SHOWN AS CONCEPTUAL AND ARE FOR ENGINEERING PURPOSES ONLY.
- CONTRACTOR SHALL PROVIDE ALL PULL AND WEIGHTS INFORMATION FOR INSTALLING EQUIPMENT. ALL PULLS SHALL BE PROVIDED TO THE CONTRACTOR BY THE MANUFACTURER'S INSTALLATION INSTRUCTIONS.
- ALL EQUIPMENT AND MATERIALS SHALL BE PROVIDED FOR THE PROJECT BY THE MANUFACTURER. THE CONTRACTOR SHALL BE RESPONSIBLE FOR THE PROPER INSTALLATION AND MAINTENANCE OF ALL EQUIPMENT AND MATERIALS.
- CONTRACTOR SHALL BE RESPONSIBLE FOR ALL NECESSARY PERMITS, INCLUDING BUT NOT LIMITED TO, PERMITS FOR ERECTION, ELECTRICAL, AND OTHER NECESSARY PERMITS.
- CONTRACTOR SHALL BE RESPONSIBLE FOR ALL NECESSARY SAFETY MEASURES, INCLUDING BUT NOT LIMITED TO, SAFETY BARRIERS, SAFETY SIGNS, AND SAFETY PERSONNEL.
- CONTRACTOR SHALL BE RESPONSIBLE FOR ALL NECESSARY PROTECTIVE MEASURES, INCLUDING BUT NOT LIMITED TO, PROTECTIVE HOUSING, PROTECTIVE COVERING, AND PROTECTIVE BARRIERS.
- CONTRACTOR SHALL BE RESPONSIBLE FOR ALL NECESSARY GROUNDING MEASURES, INCLUDING BUT NOT LIMITED TO, GROUNDING RODS, GROUNDING RINGS, AND GROUNDING BARS.
- ALL DOWN CONDUCTORS SHALL BE GALVANIZED STEEL THAT MEETS WITH THE REQUIREMENTS OF THE NATIONAL ELECTRICAL CODE (NEC) AND THE NATIONAL FIRE PROTECTION ASSOCIATION (NFPA) 70B.
- ALL WIRE SHALL BE INSTALLED IN ACCORDANCE WITH THE NATIONAL ELECTRICAL CODE (NEC) AND THE NATIONAL FIRE PROTECTION ASSOCIATION (NFPA) 70B.
- CONTRACTOR SHALL BE RESPONSIBLE FOR ALL NECESSARY LABELING AND MARKING OF ALL EQUIPMENT AND MATERIALS.

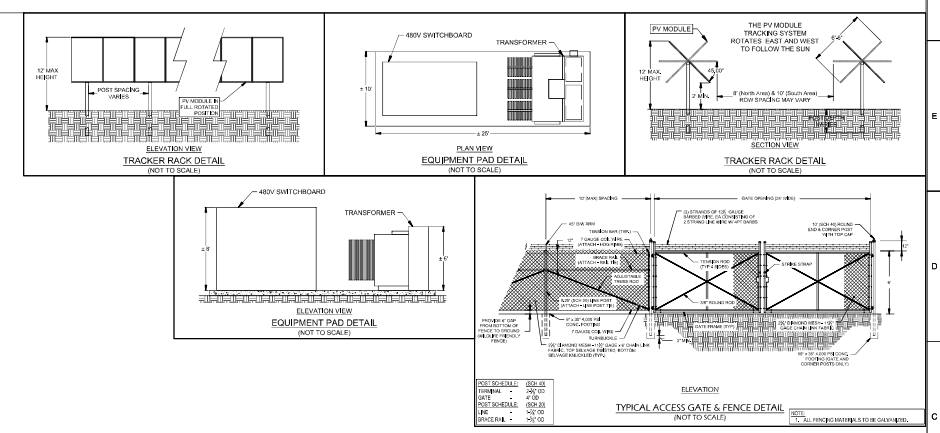

NOTES:

ALL DETAILS ON THIS SHEET HAVE BEEN PROVIDED BY CYPRESS CREEK RENEWABLES. ALL INFORMATION, MEASUREMENTS, AND REQUIREMENTS ARE TO THEIR OWN STANDARDS.

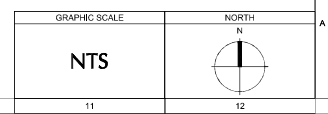

CYPRESS CREEK RENEWABLES

STATE OF NEW YORK

LANGAN

LANGAN ASSOCIATES, INC.

One North Broadway, Suite 910
White Plains, NY 10611

T: 914.323.7400 F: 914.323.4001 www.langan.com

DATE: 02/24/2023

DRAWN BY: R

CHECKED BY: R

DETAILS (2 OF 2)

C-501

LEATHERLEAF SOLAR, LLC
7501 WISON ROAD
TOWN OF BYRON, NY 14422
GENESEE COUNTY

PLANT SCHEDULE

KEY	QTY.	BOTANICAL NAME	COMMON NAME	SIZE	ROOT	REMARKS
SHADE TREE(S)						
AR	17	ACER RUBRUM	RED MAPLE	2 1/2-3" CAL.	B+B	-
PLD	4	PLATANUS OCCIDENTALIS	AMERICAN SYCAMORE	2 1/2-3" CAL.	B+B	-
QA	13	QUERCUS ALBA	WHITE OAK	2 1/2-3" CAL.	B+B	-
EVERGREEN TREE(S)						
ABS	35	ABIES BALSAMEA	BALSAM FIR	6-7'	B+B	-
JV	31	JUNIPERUS VIRGINIANA	EASTERN RED CEDAR	6-7'	B+B	-
PGL	91	PICEA GLAUCA	WHITE SPRUCE	6-7'	B+B	-
PIAB	46	PICEA ABIES	NORWAY SPRUCE	6-7'	B+B	-
PN	45	PINUS NIGRA	AUSTRIAN PINE	6-7'	B+B	-
PP	54	PICEA PUNGENS	COLORADO BLUE SPRUCE	6-7'	B+B	-
PS	92	PINUS STROBUS	EASTERN WHITE PINE	6-7'	B+B	-
DECIDUOUS SHRUB(S)						
MP	103	MYRICA PENNSYLVANICA	NORTHERN BAYBERRY	30-36"	B+B	-
SV	40	SYRINGA VULGARIS	COMMON PURPLE LILAC	3-4'	B+B	-
VD	59	VIBURNUM DENTATUM	ARROWWOOD VIBURNUM	3-4'	B+B	-
VT	40	VIBURNUM TRILOBUM	AMERICAN CRANBERRY	3-4'	B+B	-

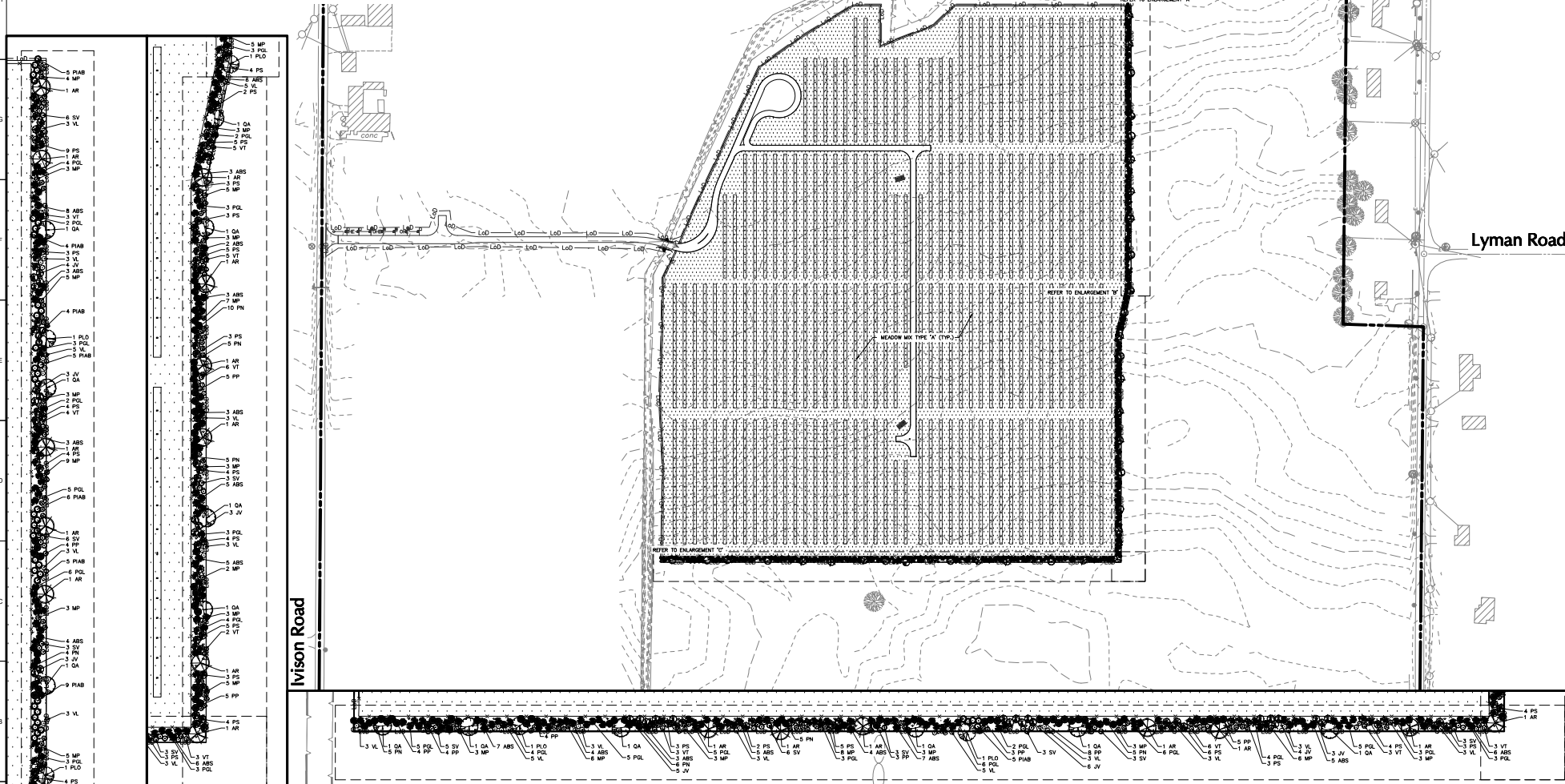

ENLARGEMENT 'A'
SCALE 1" = 40'

ENLARGEMENT 'B'
SCALE 1" = 40'

ENLARGEMENT 'C'
SCALE 1" = 40'

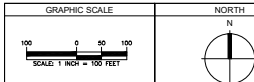
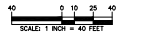

NO.	DATE	DESCRIPTION

TREE & SHRUB SPECIES FOR SCREEN PLANTING IN BYRON, NEW YORK

George Squires

April 28, 2020

Conifers

Austrian Pine (*Pinus nigra*)

Colorado Blue Spruce (*Picea pungens*)

Norway Spruce (*Picea abies*)

White Spruce (*Picea glauca*)

Eastern Red Cedar (*Juniperus virginiana*)

Shrubs

American Cranberry (*Viburnum trilobum*)

Lilac (*Syringa vulgaris*)

Nannyberry (*Viburnum lentago*)

EXHIBIT B. SEQR FULL ENVIRONMENTAL ASSESSMENT FORM – PART 1

Full Environmental Assessment Form
Part 1 - Project and Setting

Instructions for Completing Part 1

Part 1 is to be completed by the applicant or project sponsor. Responses become part of the application for approval or funding, are subject to public review, and may be subject to further verification.

Complete Part 1 based on information currently available. If additional research or investigation would be needed to fully respond to any item, please answer as thoroughly as possible based on current information; indicate whether missing information does not exist, or is not reasonably available to the sponsor; and, when possible, generally describe work or studies which would be necessary to update or fully develop that information.

Applicants/sponsors must complete all items in Sections A & B. In Sections C, D & E, most items contain an initial question that must be answered either "Yes" or "No". If the answer to the initial question is "Yes", complete the sub-questions that follow. If the answer to the initial question is "No", proceed to the next question. Section F allows the project sponsor to identify and attach any additional information. Section G requires the name and signature of the applicant or project sponsor to verify that the information contained in Part I is accurate and complete.

A. Project and Applicant/Sponsor Information.

Name of Action or Project: Leatherleaf Solar, LLC		
Project Location (describe, and attach a general location map): 7501 Ivison Rd, Byron, NY. Parcel: 9.-1-7.113		
Brief Description of Proposed Action (include purpose or need): Leatherleaf Solar, LLC is proposing to construct a 5.00MWac solar photovoltaic (pv) system on a 35 acre portion of the parcel listed above, and illustrated on the attached map. This project will consist of ground-mounted solar pv panels. The construction of the system will involve driving posts approximately 6-10' into the ground, or at depths appropriate for frost conditions, every 12-16' and mounting panel racks to the posts. The Leatherleaf Solar project is a Community Distributed Generation (CDG) facility as prescribed by the New York State Public Service Commission under the electric tariffs of National Grid Electric. As a CDG facility, the project will provide clean energy to the existing electric grid operated by National Grid Electric and offer local customers the opportunity to contract for this energy at or below current market rates.		
Name of Applicant/Sponsor: Leatherleaf Solar, LLC	Telephone: 828-269-4446	E-Mail: bernardo.urdaneta@ccrenew.com
Address: P.O. Box 173		
City/PO: Latham	State: NY	Zip Code: 12110
Project Contact (if not same as sponsor; give name and title/role): Bernardo Urdaneta (Project Developer)	Telephone: 828-269-4446	E-Mail: bernardo.urdaneta@ccherenew.com
Address: P.O. Box 173		
City/PO: Latham	State: NY	Zip Code: 12110
Property Owner (if not same as sponsor): Dean Ivison	Telephone: 585-414-3432	E-Mail: deanivison@gmail.com
Address: 7412 Coward Rd		
City/PO: Byron	State: NY	Zip Code: 14422

B. Government Approvals

B. Government Approvals, Funding, or Sponsorship. (“Funding” includes grants, loans, tax relief, and any other forms of financial assistance.)

Government Entity	If Yes: Identify Agency and Approval(s) Required	Application Date (Actual or projected)
a. City Counsel, Town Board, <input checked="" type="checkbox"/> Yes <input type="checkbox"/> No or Village Board of Trustees	Town of Byron Town Board: PILOT	Est. April 2023
b. City, Town or Village Planning Board or Commission <input checked="" type="checkbox"/> Yes <input type="checkbox"/> No	Town Planning Board: Special Use Permit and Site Plan Review	Est. April 2023
c. City, Town or Village Zoning Board of Appeals <input type="checkbox"/> Yes <input checked="" type="checkbox"/> No		
d. Other local agencies <input checked="" type="checkbox"/> Yes <input type="checkbox"/> No	Byron-Bergen Central School District	Est. April 2023
e. County agencies <input checked="" type="checkbox"/> Yes <input type="checkbox"/> No	Genesee County Planning Board Review: PILOT	Est. May 2023
f. Regional agencies <input type="checkbox"/> Yes <input checked="" type="checkbox"/> No		
g. State agencies <input checked="" type="checkbox"/> Yes <input type="checkbox"/> No	NYSDEC-SPEDES, SHPO	February 2023
h. Federal agencies <input checked="" type="checkbox"/> Yes <input type="checkbox"/> No	US Army Corps of Engineers	January 2023
i. Coastal Resources. i. Is the project site within a Coastal Area, or the waterfront area of a Designated Inland Waterway? <input type="checkbox"/> Yes <input checked="" type="checkbox"/> No ii. Is the project site located in a community with an approved Local Waterfront Revitalization Program? <input type="checkbox"/> Yes <input checked="" type="checkbox"/> No iii. Is the project site within a Coastal Erosion Hazard Area? <input type="checkbox"/> Yes <input checked="" type="checkbox"/> No		

C. Planning and Zoning

C.1. Planning and zoning actions.

Will administrative or legislative adoption, or amendment of a plan, local law, ordinance, rule or regulation be the only approval(s) which must be granted to enable the proposed action to proceed? Yes No

- If Yes, complete sections C, F and G.
- If No, proceed to question C.2 and complete all remaining sections and questions in Part 1

C.2. Adopted land use plans.

a. Do any municipally- adopted (city, town, village or county) comprehensive land use plan(s) include the site where the proposed action would be located? Yes No
 If Yes, does the comprehensive plan include specific recommendations for the site where the proposed action would be located? Yes No

b. Is the site of the proposed action within any local or regional special planning district (for example: Greenway; Brownfield Opportunity Area (BOA); designated State or Federal heritage area; watershed management plan; or other?) Yes No
 If Yes, identify the plan(s):

c. Is the proposed action located wholly or partially within an area listed in an adopted municipal open space plan, or an adopted municipal farmland protection plan? Yes No
 If Yes, identify the plan(s):

C.3. Zoning

a. Is the site of the proposed action located in a municipality with an adopted zoning law or ordinance. Yes No
 If Yes, what is the zoning classification(s) including any applicable overlay district?
 The parcel is located in the Agricultural-Residential zoning district of the Town of Byron

b. Is the use permitted or allowed by a special or conditional use permit? Yes No

c. Is a zoning change requested as part of the proposed action? Yes No
 If Yes,
 i. What is the proposed new zoning for the site? _____

C.4. Existing community services.

a. In what school district is the project site located? Byron-Bergen School District

b. What police or other public protection forces serve the project site?
 Genesee County Police

c. Which fire protection and emergency medical services serve the project site?
 Byron Fire Department #1; United Memorial Medical Center

d. What parks serve the project site?
 Trestle Park, Byron Community Park, Turtle Park

D. Project Details

D.1. Proposed and Potential Development

a. What is the general nature of the proposed action (e.g., residential, industrial, commercial, recreational; if mixed, include all components)? Commercial Large-Scale Solar Energy System

b. a. Total acreage of the site of the proposed action? _____ 179.9 acres
 b. Total acreage to be physically disturbed? _____ 35 acres
 c. Total acreage (project site and any contiguous properties) owned or controlled by the applicant or project sponsor? _____ 35 acres

c. Is the proposed action an expansion of an existing project or use? Yes No
 i. If Yes, what is the approximate percentage of the proposed expansion and identify the units (e.g., acres, miles, housing units, square feet)? % _____ Units: _____

d. Is the proposed action a subdivision, or does it include a subdivision? Yes No
 If Yes,
 i. Purpose or type of subdivision? (e.g., residential, industrial, commercial; if mixed, specify types) _____
 ii. Is a cluster/conservation layout proposed? Yes No
 iii. Number of lots proposed? _____
 iv. Minimum and maximum proposed lot sizes? Minimum _____ Maximum _____

e. Will the proposed action be constructed in multiple phases? Yes No
 i. If No, anticipated period of construction: _____ 4-5 months
 ii. If Yes:
 • Total number of phases anticipated _____
 • Anticipated commencement date of phase 1 (including demolition) _____ month _____ year
 • Anticipated completion date of final phase _____ month _____ year
 • Generally describe connections or relationships among phases, including any contingencies where progress of one phase may determine timing or duration of future phases: _____

f. Does the project include new residential uses? Yes No

If Yes, show numbers of units proposed.

	<u>One Family</u>	<u>Two Family</u>	<u>Three Family</u>	<u>Multiple Family (four or more)</u>
Initial Phase	_____	_____	_____	_____
At completion	_____	_____	_____	_____
of all phases	_____	_____	_____	_____

g. Does the proposed action include new non-residential construction (including expansions)? Yes No

If Yes,

- i. Total number of structures N/A
- ii. Dimensions (in feet) of largest proposed structure: N/A height; N/A width; and N/A length
- iii. Approximate extent of building space to be heated or cooled: N/A square feet

h. Does the proposed action include construction or other activities that will result in the impoundment of any liquids, such as creation of a water supply, reservoir, pond, lake, waste lagoon or other storage? Yes No

If Yes,

- i. Purpose of the impoundment: _____
- ii. If a water impoundment, the principal source of the water: Ground water Surface water streams Other specify: _____
- iii. If other than water, identify the type of impounded/contained liquids and their source. _____
- iv. Approximate size of the proposed impoundment. Volume: _____ million gallons; surface area: _____ acres
- v. Dimensions of the proposed dam or impounding structure: _____ height; _____ length
- vi. Construction method/materials for the proposed dam or impounding structure (e.g., earth fill, rock, wood, concrete): _____

D.2. Project Operations

a. Does the proposed action include any excavation, mining, or dredging, during construction, operations, or both? (Not including general site preparation, grading or installation of utilities or foundations where all excavated materials will remain onsite) Yes No

If Yes:

- i. What is the purpose of the excavation or dredging? _____
- ii. How much material (including rock, earth, sediments, etc.) is proposed to be removed from the site?
 - Volume (specify tons or cubic yards): _____
 - Over what duration of time? _____
- iii. Describe nature and characteristics of materials to be excavated or dredged, and plans to use, manage or dispose of them. _____
- iv. Will there be onsite dewatering or processing of excavated materials? Yes No
If yes, describe. _____
- v. What is the total area to be dredged or excavated? _____ acres
- vi. What is the maximum area to be worked at any one time? _____ acres
- vii. What would be the maximum depth of excavation or dredging? _____ feet
- viii. Will the excavation require blasting? Yes No
- ix. Summarize site reclamation goals and plan: _____

b. Would the proposed action cause or result in alteration of, increase or decrease in size of, or encroachment into any existing wetland, waterbody, shoreline, beach or adjacent area? Yes No

If Yes:

- i. Identify the wetland or waterbody which would be affected (by name, water index number, wetland map number or geographic description): _____

ii. Describe how the proposed action would affect that waterbody or wetland, e.g. excavation, fill, placement of structures, or alteration of channels, banks and shorelines. Indicate extent of activities, alterations and additions in square feet or acres:

iii. Will the proposed action cause or result in disturbance to bottom sediments? Yes No
 If Yes, describe: _____

iv. Will the proposed action cause or result in the destruction or removal of aquatic vegetation? Yes No
 If Yes:

- acres of aquatic vegetation proposed to be removed: _____
- expected acreage of aquatic vegetation remaining after project completion: _____
- purpose of proposed removal (e.g. beach clearing, invasive species control, boat access): _____
- proposed method of plant removal: _____
- if chemical/herbicide treatment will be used, specify product(s): _____

v. Describe any proposed reclamation/mitigation following disturbance: _____

c. Will the proposed action use, or create a new demand for water? Yes No

If Yes:

i. Total anticipated water usage/demand per day: _____ gallons/day

ii. Will the proposed action obtain water from an existing public water supply? Yes No

If Yes:

- Name of district or service area: _____
- Does the existing public water supply have capacity to serve the proposal? Yes No
- Is the project site in the existing district? Yes No
- Is expansion of the district needed? Yes No
- Do existing lines serve the project site? Yes No

iii. Will line extension within an existing district be necessary to supply the project? Yes No

If Yes:

- Describe extensions or capacity expansions proposed to serve this project: _____
- Source(s) of supply for the district: _____

iv. Is a new water supply district or service area proposed to be formed to serve the project site? Yes No

If Yes:

- Applicant/sponsor for new district: _____
- Date application submitted or anticipated: _____
- Proposed source(s) of supply for new district: _____

v. If a public water supply will not be used, describe plans to provide water supply for the project: _____

vi. If water supply will be from wells (public or private), what is the maximum pumping capacity: _____ gallons/minute.

d. Will the proposed action generate liquid wastes? Yes No

If Yes:

i. Total anticipated liquid waste generation per day: _____ gallons/day

ii. Nature of liquid wastes to be generated (e.g., sanitary wastewater, industrial; if combination, describe all components and approximate volumes or proportions of each): _____

iii. Will the proposed action use any existing public wastewater treatment facilities? Yes No

If Yes:

- Name of wastewater treatment plant to be used: _____
- Name of district: _____
- Does the existing wastewater treatment plant have capacity to serve the project? Yes No
- Is the project site in the existing district? Yes No
- Is expansion of the district needed? Yes No

- Do existing sewer lines serve the project site? Yes No
- Will a line extension within an existing district be necessary to serve the project? Yes No

If Yes:

- Describe extensions or capacity expansions proposed to serve this project: _____

iv. Will a new wastewater (sewage) treatment district be formed to serve the project site? Yes No

If Yes:

- Applicant/sponsor for new district: _____
- Date application submitted or anticipated: _____
- What is the receiving water for the wastewater discharge? _____

v. If public facilities will not be used, describe plans to provide wastewater treatment for the project, including specifying proposed receiving water (name and classification if surface discharge or describe subsurface disposal plans):

vi. Describe any plans or designs to capture, recycle or reuse liquid waste: _____

e. Will the proposed action disturb more than one acre and create stormwater runoff, either from new point sources (i.e. ditches, pipes, swales, curbs, gutters or other concentrated flows of stormwater) or non-point source (i.e. sheet flow) during construction or post construction? Yes No

If Yes:

i. How much impervious surface will the project create in relation to total size of project parcel?

_____ Square feet or 0.1 acres (impervious surface)

_____ Square feet or 179.9 acres (parcel size)

ii. Describe types of new point sources. No new point source discharges

iii. Where will the stormwater runoff be directed (i.e. on-site stormwater management facility/structures, adjacent properties, groundwater, on-site surface water or off-site surface waters)?

Stormwater will flow off panels to the ground and drain as normal to surface water on and around the site. Appropriate stormwater controls will be implemented during construction.

- If to surface waters, identify receiving water bodies or wetlands: _____

- Will stormwater runoff flow to adjacent properties? Yes No

iv. Does the proposed plan minimize impervious surfaces, use pervious materials or collect and re-use stormwater? Yes No

f. Does the proposed action include, or will it use on-site, one or more sources of air emissions, including fuel combustion, waste incineration, or other processes or operations? Yes No

If Yes, identify:

i. Mobile sources during project operations (e.g., heavy equipment, fleet or delivery vehicles)

Heavy equipment during the construction period.

ii. Stationary sources during construction (e.g., power generation, structural heating, batch plant, crushers)

iii. Stationary sources during operations (e.g., process emissions, large boilers, electric generation)

g. Will any air emission sources named in D.2.f (above), require a NY State Air Registration, Air Facility Permit, or Federal Clean Air Act Title IV or Title V Permit? Yes No

If Yes:

i. Is the project site located in an Air quality non-attainment area? (Area routinely or periodically fails to meet ambient air quality standards for all or some parts of the year) Yes No

ii. In addition to emissions as calculated in the application, the project will generate:

- _____ Tons/year (short tons) of Carbon Dioxide (CO₂)
- _____ Tons/year (short tons) of Nitrous Oxide (N₂O)
- _____ Tons/year (short tons) of Perfluorocarbons (PFCs)
- _____ Tons/year (short tons) of Sulfur Hexafluoride (SF₆)
- _____ Tons/year (short tons) of Carbon Dioxide equivalent of Hydrofluorocarbons (HFCs)
- _____ Tons/year (short tons) of Hazardous Air Pollutants (HAPs)

h. Will the proposed action generate or emit methane (including, but not limited to, sewage treatment plants, landfills, composting facilities)? Yes No

If Yes:

- i. Estimate methane generation in tons/year (metric): _____
- ii. Describe any methane capture, control or elimination measures included in project design (e.g., combustion to generate heat or electricity, flaring): _____

i. Will the proposed action result in the release of air pollutants from open-air operations or processes, such as quarry or landfill operations? Yes No

If Yes: Describe operations and nature of emissions (e.g., diesel exhaust, rock particulates/dust):

j. Will the proposed action result in a substantial increase in traffic above present levels or generate substantial new demand for transportation facilities or services? Yes No

If Yes:

- i. When is the peak traffic expected (Check all that apply): Morning Evening Weekend
 Randomly between hours of _____ to _____.
- ii. For commercial activities only, projected number of truck trips/day and type (e.g., semi trailers and dump trucks): _____

iii. Parking spaces: Existing _____ Proposed _____ Net increase/decrease _____

iv. Does the proposed action include any shared use parking? Yes No

v. If the proposed action includes any modification of existing roads, creation of new roads or change in existing access, describe:

vi. Are public/private transportation service(s) or facilities available within 1/2 mile of the proposed site? Yes No

vii. Will the proposed action include access to public transportation or accommodations for use of hybrid, electric or other alternative fueled vehicles? Yes No

viii. Will the proposed action include plans for pedestrian or bicycle accommodations for connections to existing pedestrian or bicycle routes? Yes No

k. Will the proposed action (for commercial or industrial projects only) generate new or additional demand for energy? Yes No

If Yes:

i. Estimate annual electricity demand during operation of the proposed action: _____

ii. Anticipated sources/suppliers of electricity for the project (e.g., on-site combustion, on-site renewable, via grid/local utility, or other):

iii. Will the proposed action require a new, or an upgrade, to an existing substation? Yes No

l. Hours of operation. Answer all items which apply.

i. During Construction:

- Monday - Friday: _____ 7:00AM - 7:00PM _____
- Saturday: _____ N/A _____
- Sunday: _____ N/A _____
- Holidays: _____ N/A _____

ii. During Operations:

- Monday - Friday: _____ 24/7 _____
- Saturday: _____ 24/7 _____
- Sunday: _____ 24/7 _____
- Holidays: _____ 24/7 _____

m. Will the proposed action produce noise that will exceed existing ambient noise levels during construction, operation, or both? Yes No

If yes:

i. Provide details including sources, time of day and duration:

Noise levels will exceed ambient levels during construction only (16-20 weeks) from use of heavy equipment, including hydraulic pile drivers, excavators, telescopic forklifts, and skid steer loaders. During operation, inverters produce low level noise that will not exceed ambient levels outside the fence line.

ii. Will the proposed action remove existing natural barriers that could act as a noise barrier or screen? Yes No

Describe: _____

n. Will the proposed action have outdoor lighting? Yes No

If yes:

i. Describe source(s), location(s), height of fixture(s), direction/aim, and proximity to nearest occupied structures:

ii. Will proposed action remove existing natural barriers that could act as a light barrier or screen? Yes No

Describe: _____

o. Does the proposed action have the potential to produce odors for more than one hour per day? Yes No

If Yes, describe possible sources, potential frequency and duration of odor emissions, and proximity to nearest occupied structures: _____

p. Will the proposed action include any bulk storage of petroleum (combined capacity of over 1,100 gallons) or chemical products 185 gallons in above ground storage or any amount in underground storage? Yes No

If Yes:

i. Product(s) to be stored _____

ii. Volume(s) _____ per unit time _____ (e.g., month, year)

iii. Generally, describe the proposed storage facilities: _____

q. Will the proposed action (commercial, industrial and recreational projects only) use pesticides (i.e., herbicides, insecticides) during construction or operation? Yes No

If Yes:

i. Describe proposed treatment(s):

During construction, as a prerequisite to pollinator establishment, herbicides will be applied prior to pollinator habitat prep. This will occur while storm water measures are in place controlling off site sediment exposure. During facility operation, herbicides may be utilized for vegetation management. Under circumstances where herbicides are deemed necessary, an effort is made to minimize use and to only apply highly biodegradable, EPA registered and approved solutions that are nontoxic to pets and wildlife.

ii. Will the proposed action use Integrated Pest Management Practices? Yes No

r. Will the proposed action (commercial or industrial projects only) involve or require the management or disposal of solid waste (excluding hazardous materials)? Yes No

If Yes:

i. Describe any solid waste(s) to be generated during construction or operation of the facility:

• Construction: _____ Approx. 30 tons per _____ 16-20 weeks (unit of time)

• Operation : _____ tons per _____ (unit of time)

ii. Describe any proposals for on-site minimization, recycling or reuse of materials to avoid disposal as solid waste:

• Construction: Wooden pallets from the transport of the solar panels are recycled whenever possible.

• Operation: N/A

iii. Proposed disposal methods/facilities for solid waste generated on-site:

• Construction: Solid waste generated on-site is picked up via dumpster and transported to the landfill used by the dumpster company.

• Operation: N/A

s. Does the proposed action include construction or modification of a solid waste management facility? Yes No

If Yes:

- i. Type of management or handling of waste proposed for the site (e.g., recycling or transfer station, composting, landfill, or other disposal activities): _____
- ii. Anticipated rate of disposal/processing:
- _____ Tons/month, if transfer or other non-combustion/thermal treatment, or
 - _____ Tons/hour, if combustion or thermal treatment
- iii. If landfill, anticipated site life: _____ years

t. Will the proposed action at the site involve the commercial generation, treatment, storage, or disposal of hazardous waste? Yes No

If Yes:

- i. Name(s) of all hazardous wastes or constituents to be generated, handled or managed at facility: _____
- ii. Generally describe processes or activities involving hazardous wastes or constituents: _____
- iii. Specify amount to be handled or generated _____ tons/month
- iv. Describe any proposals for on-site minimization, recycling or reuse of hazardous constituents: _____
- v. Will any hazardous wastes be disposed at an existing offsite hazardous waste facility? Yes No

If Yes: provide name and location of facility: _____

If No: describe proposed management of any hazardous wastes which will not be sent to a hazardous waste facility: _____

E. Site and Setting of Proposed Action

E.1. Land uses on and surrounding the project site

a. Existing land uses.

i. Check all uses that occur on, adjoining and near the project site.

- Urban Industrial Commercial Residential (suburban) Rural (non-farm)
 Forest Agriculture Aquatic Other (specify): _____

ii. If mix of uses, generally describe:

The immediately surrounding properties consist of agricultural crop fields, a forest (to the north) and rural/residential dwellings.

b. Land uses and covertypes on the project site.

Land use or Covertype	Current Acreage	Acreage After Project Completion	Change (Acres +/-)
• Roads, buildings, and other paved or impervious surfaces	0.46	0.46	0.00
• Forested	10.11	10.11	0.00
• Meadows, grasslands or brushlands (non-agricultural, including abandoned agricultural)	1.25	34.43	33.18
• Agricultural (includes active orchards, field, greenhouse etc.)	159.91	125.38	-34.52
• Surface water features (lakes, ponds, streams, rivers, etc.)	0.19	0.19	0.00
• Wetlands (freshwater or tidal)	5.82	5.82	0.00
• Non-vegetated (bare rock, earth or fill)	0.00	0.00	0.00
• Other Describe: <u>Permeable haul road</u>	0.00	1.23	1.23

<p>c. Is the project site presently used by members of the community for public recreation? <input type="checkbox"/> Yes <input checked="" type="checkbox"/> No</p> <p>i. If Yes: explain: _____</p>
<p>d. Are there any facilities serving children, the elderly, people with disabilities (e.g., schools, hospitals, licensed day care centers, or group homes) within 1500 feet of the project site? <input type="checkbox"/> Yes <input checked="" type="checkbox"/> No</p> <p>If Yes,</p> <p>i. Identify Facilities: _____</p>
<p>e. Does the project site contain an existing dam? <input type="checkbox"/> Yes <input checked="" type="checkbox"/> No</p> <p>If Yes:</p> <p>i. Dimensions of the dam and impoundment:</p> <ul style="list-style-type: none"> • Dam height: _____ feet • Dam length: _____ feet • Surface area: _____ acres • Volume impounded: _____ gallons OR acre-feet <p>ii. Dam's existing hazard classification: _____</p> <p>iii. Provide date and summarize results of last inspection: _____</p>
<p>f. Has the project site ever been used as a municipal, commercial or industrial solid waste management facility, or does the project site adjoin property which is now, or was at one time, used as a solid waste management facility? <input type="checkbox"/> Yes <input checked="" type="checkbox"/> No</p> <p>If Yes:</p> <p>i. Has the facility been formally closed? <input type="checkbox"/> Yes <input type="checkbox"/> No</p> <ul style="list-style-type: none"> • If yes, cite sources/documentation: _____ <p>ii. Describe the location of the project site relative to the boundaries of the solid waste management facility: _____</p> <p>iii. Describe any development constraints due to the prior solid waste activities: _____</p>
<p>g. Have hazardous wastes been generated, treated and/or disposed of at the site, or does the project site adjoin property which is now or was at one time used to commercially treat, store and/or dispose of hazardous waste? <input type="checkbox"/> Yes <input checked="" type="checkbox"/> No</p> <p>If Yes:</p> <p>i. Describe waste(s) handled and waste management activities, including approximate time when activities occurred: _____</p>
<p>h. Potential contamination history. Has there been a reported spill at the proposed project site, or have any remedial actions been conducted at or adjacent to the proposed site? <input type="checkbox"/> Yes <input checked="" type="checkbox"/> No</p> <p>If Yes:</p> <p>i. Is any portion of the site listed on the NYSDEC Spills Incidents database or Environmental Site Remediation database? Check all that apply: <input type="checkbox"/> Yes <input type="checkbox"/> No</p> <ul style="list-style-type: none"> <input type="checkbox"/> Yes – Spills Incidents database Provide DEC ID number(s): _____ <input type="checkbox"/> Yes – Environmental Site Remediation database Provide DEC ID number(s): _____ <input type="checkbox"/> Neither database <p>ii. If site has been subject of RCRA corrective activities, describe control measures: _____</p> <p>iii. Is the project within 2000 feet of any site in the NYSDEC Environmental Site Remediation database? <input type="checkbox"/> Yes <input type="checkbox"/> No</p> <p>If yes, provide DEC ID number(s): _____</p> <p>iv. If yes to (i), (ii) or (iii) above, describe current status of site(s): _____</p>

v. Is the project site subject to an institutional control limiting property uses? <input type="checkbox"/> Yes <input checked="" type="checkbox"/> No <ul style="list-style-type: none"> • If yes, DEC site ID number: _____ • Describe the type of institutional control (e.g., deed restriction or easement): _____ • Describe any use limitations: _____ • Describe any engineering controls: _____ • Will the project affect the institutional or engineering controls in place? <input type="checkbox"/> Yes <input type="checkbox"/> No • Explain: _____ _____ 						
E.2. Natural Resources On or Near Project Site						
a. What is the average depth to bedrock on the project site? _____ >6.5 feet						
b. Are there bedrock outcroppings on the project site? <input type="checkbox"/> Yes <input checked="" type="checkbox"/> No If Yes, what proportion of the site is comprised of bedrock outcroppings? _____ %						
c. Predominant soil type(s) present on project site: <table style="width: 100%; border-collapse: collapse;"> <tr> <td style="border-bottom: 1px solid black;">Appleton silt loam</td> <td style="border-bottom: 1px solid black; text-align: right;">26 %</td> </tr> <tr> <td style="border-bottom: 1px solid black;">Ontario loam</td> <td style="border-bottom: 1px solid black; text-align: right;">28.8 %</td> </tr> <tr> <td style="border-bottom: 1px solid black;">Lima silt loam</td> <td style="border-bottom: 1px solid black; text-align: right;">45.2 %</td> </tr> </table>	Appleton silt loam	26 %	Ontario loam	28.8 %	Lima silt loam	45.2 %
Appleton silt loam	26 %					
Ontario loam	28.8 %					
Lima silt loam	45.2 %					
d. What is the average depth to the water table on the project site? Average: _____ 2 feet						
e. Drainage status of project site soils: <table style="width: 100%; border-collapse: collapse;"> <tr> <td style="padding-left: 20px;"><input checked="" type="checkbox"/> Well Drained:</td> <td style="text-align: right;">29 % of site</td> </tr> <tr> <td style="padding-left: 20px;"><input checked="" type="checkbox"/> Moderately Well Drained:</td> <td style="text-align: right;">45 % of site</td> </tr> <tr> <td style="padding-left: 20px;"><input checked="" type="checkbox"/> Poorly Drained</td> <td style="text-align: right;">26 % of site</td> </tr> </table>	<input checked="" type="checkbox"/> Well Drained:	29 % of site	<input checked="" type="checkbox"/> Moderately Well Drained:	45 % of site	<input checked="" type="checkbox"/> Poorly Drained	26 % of site
<input checked="" type="checkbox"/> Well Drained:	29 % of site					
<input checked="" type="checkbox"/> Moderately Well Drained:	45 % of site					
<input checked="" type="checkbox"/> Poorly Drained	26 % of site					
f. Approximate proportion of proposed action site with slopes: <table style="width: 100%; border-collapse: collapse;"> <tr> <td style="padding-left: 20px;"><input checked="" type="checkbox"/> 0-10%:</td> <td style="text-align: right;">_____ % of site</td> </tr> <tr> <td style="padding-left: 20px;"><input type="checkbox"/> 10-15%:</td> <td style="text-align: right;">_____ % of site</td> </tr> <tr> <td style="padding-left: 20px;"><input type="checkbox"/> 15% or greater:</td> <td style="text-align: right;">_____ % of site</td> </tr> </table>	<input checked="" type="checkbox"/> 0-10%:	_____ % of site	<input type="checkbox"/> 10-15%:	_____ % of site	<input type="checkbox"/> 15% or greater:	_____ % of site
<input checked="" type="checkbox"/> 0-10%:	_____ % of site					
<input type="checkbox"/> 10-15%:	_____ % of site					
<input type="checkbox"/> 15% or greater:	_____ % of site					
g. Are there any unique geologic features on the project site? <input type="checkbox"/> Yes <input checked="" type="checkbox"/> No If Yes, describe: _____ _____						
h. Surface water features. <ul style="list-style-type: none"> i. Does any portion of the project site contain wetlands or other waterbodies (including streams, rivers, ponds or lakes)? <input checked="" type="checkbox"/> Yes <input type="checkbox"/> No ii. Do any wetlands or other waterbodies adjoin the project site? <input checked="" type="checkbox"/> Yes <input type="checkbox"/> No If Yes to either <i>i</i> or <i>ii</i> , continue. If No, skip to E.2.i. <ul style="list-style-type: none"> iii. Are any of the wetlands or waterbodies within or adjoining the project site regulated by any federal, state or local agency? <input checked="" type="checkbox"/> Yes <input type="checkbox"/> No iv. For each identified regulated wetland and waterbody on the project site, provide the following information: <table style="width: 100%; border-collapse: collapse;"> <tr> <td style="padding-left: 20px;">• Streams: Name <u>821-40</u> Classification <u>C</u></td> </tr> <tr> <td style="padding-left: 20px;">• Lakes or Ponds: Name _____ Classification _____</td> </tr> <tr> <td style="padding-left: 20px;">• Wetlands: Name <u>PFO1E, PEM1E, PUB1H</u> Approximate Size <u>11.96 acres</u></td> </tr> <tr> <td style="padding-left: 20px;">• Wetland No. (if regulated by DEC) _____</td> </tr> </table> 	• Streams: Name <u>821-40</u> Classification <u>C</u>	• Lakes or Ponds: Name _____ Classification _____	• Wetlands: Name <u>PFO1E, PEM1E, PUB1H</u> Approximate Size <u>11.96 acres</u>	• Wetland No. (if regulated by DEC) _____		
• Streams: Name <u>821-40</u> Classification <u>C</u>						
• Lakes or Ponds: Name _____ Classification _____						
• Wetlands: Name <u>PFO1E, PEM1E, PUB1H</u> Approximate Size <u>11.96 acres</u>						
• Wetland No. (if regulated by DEC) _____						
v. Are any of the above water bodies listed in the most recent compilation of NYS water quality-impaired waterbodies? <input type="checkbox"/> Yes <input checked="" type="checkbox"/> No If yes, name of impaired water body/bodies and basis for listing as impaired: _____ _____						
i. Is the project site in a designated Floodway? <input type="checkbox"/> Yes <input checked="" type="checkbox"/> No						
j. Is the project site in the 100-year Floodplain? <input type="checkbox"/> Yes <input checked="" type="checkbox"/> No						
k. Is the project site in the 500-year Floodplain? <input type="checkbox"/> Yes <input checked="" type="checkbox"/> No						
l. Is the project site located over, or immediately adjoining, a primary, principal or sole source aquifer? <input type="checkbox"/> Yes <input checked="" type="checkbox"/> No If Yes: <ul style="list-style-type: none"> i. Name of aquifer: _____ 						

m. Identify the predominant wildlife species that occupy or use the project site:		
White-tailed deer (<i>odocoileus virginianu</i>)	Striped skunk (<i>Memphitis mephitis</i>)	Gray squirrel (<i>Sciurus Carolinensis</i>)
Raccoon (<i>Procyron lotor</i>)	American Robin (<i>Turdus migratorius</i>)	Red-tailed hawk (<i>Buteo jamaicensis</i>)
Eastern coyote (<i>Canis latrans</i>)	Red fox (<i>Vulpes Vulpes</i>)	
n. Does the project site contain a designated significant natural community? <input type="checkbox"/> Yes <input checked="" type="checkbox"/> No		
If Yes:		
i. Describe the habitat/community (composition, function, and basis for designation): _____		
ii. Source(s) of description or evaluation: _____		
iii. Extent of community/habitat:		
• Currently:	_____	acres
• Following completion of project as proposed:	_____	acres
• Gain or loss (indicate + or -):	_____	acres
o. Does project site contain any species of plant or animal that is listed by the federal government or NYS as endangered or threatened, or does it contain any areas identified as habitat for an endangered or threatened species? <input checked="" type="checkbox"/> Yes <input type="checkbox"/> No		
If Yes:		
i. Species and listing (endangered or threatened): _____		
One federally threatened species identified: Eastern massasauga (<i>sistrurus catenatus</i>). No critical habitats identified. We are currently consulting with the environmental agencies and do not expect it to be present on site given its historic agricultural use.		
p. Does the project site contain any species of plant or animal that is listed by NYS as rare, or as a species of special concern? <input type="checkbox"/> Yes <input checked="" type="checkbox"/> No		
If Yes:		
i. Species and listing: _____		
q. Is the project site or adjoining area currently used for hunting, trapping, fishing or shell fishing? <input type="checkbox"/> Yes <input checked="" type="checkbox"/> No		
If yes, give a brief description of how the proposed action may affect that use: _____		
E.3. Designated Public Resources On or Near Project Site		
a. Is the project site, or any portion of it, located in a designated agricultural district certified pursuant to Agriculture and Markets Law, Article 25-AA, Section 303 and 304? <input checked="" type="checkbox"/> Yes <input type="checkbox"/> No		
If Yes, provide county plus district name/number: <u>Genesee County - District 4</u>		
b. Are agricultural lands consisting of highly productive soils present? <input checked="" type="checkbox"/> Yes <input type="checkbox"/> No		
i. If Yes: acreage(s) on project site? <u>26 acres, and another 9 acres if drained</u>		
ii. Source(s) of soil rating(s): <u>USDA NRCS Web Soil Survey Farmland Classification</u>		
c. Does the project site contain all or part of, or is it substantially contiguous to, a registered National Natural Landmark? <input type="checkbox"/> Yes <input checked="" type="checkbox"/> No		
If Yes:		
i. Nature of the natural landmark: <input type="checkbox"/> Biological Community <input type="checkbox"/> Geological Feature		
ii. Provide brief description of landmark, including values behind designation and approximate size/extent: _____		
d. Is the project site located in or does it adjoin a state listed Critical Environmental Area? <input type="checkbox"/> Yes <input checked="" type="checkbox"/> No		
If Yes:		
i. CEA name: _____		
ii. Basis for designation: _____		
iii. Designating agency and date: _____		

e. Does the project site contain, or is it substantially contiguous to, a building, archaeological site, or district which is listed on the National or State Register of Historic Places, or that has been determined by the Commissioner of the NYS Office of Parks, Recreation and Historic Preservation to be eligible for listing on the State Register of Historic Places?	<input type="checkbox"/> Yes <input checked="" type="checkbox"/> No
If Yes:	
i. Nature of historic/archaeological resource: <input type="checkbox"/> Archaeological Site <input type="checkbox"/> Historic Building or District	
ii. Name: _____	
iii. Brief description of attributes on which listing is based: _____	
f. Is the project site, or any portion of it, located in or adjacent to an area designated as sensitive for archaeological sites on the NY State Historic Preservation Office (SHPO) archaeological site inventory?	<input type="checkbox"/> Yes <input checked="" type="checkbox"/> No
g. Have additional archaeological or historic site(s) or resources been identified on the project site?	<input type="checkbox"/> Yes <input checked="" type="checkbox"/> No
If Yes:	
i. Describe possible resource(s): _____	
ii. Basis for identification: _____	
h. Is the project site within five miles of any officially designated and publicly accessible federal, state, or local scenic or aesthetic resource?	<input checked="" type="checkbox"/> Yes <input type="checkbox"/> No
If Yes:	
i. Identify resource: <u>Trestle Park, Byron Community Park, Turtle Park</u>	
ii. Nature of, or basis for, designation (e.g., established highway overlook, state or local park, state historic trail or scenic byway, etc.): <u>Community Parks</u>	
iii. Distance between project and resource: _____ <u>4.5</u> miles.	
i. Is the project site located within a designated river corridor under the Wild, Scenic and Recreational Rivers Program 6 NYCRR 666?	<input type="checkbox"/> Yes <input checked="" type="checkbox"/> No
If Yes:	
i. Identify the name of the river and its designation: _____	
ii. Is the activity consistent with development restrictions contained in 6NYCRR Part 666? <input type="checkbox"/> Yes <input type="checkbox"/> No	

F. Additional Information

Attach any additional information which may be needed to clarify your project.

If you have identified any adverse impacts which could be associated with your proposal, please describe those impacts plus any measures which you propose to avoid or minimize them.

G. Verification

I certify that the information provided is true to the best of my knowledge.

Applicant/Sponsor Name Geoff Johnson Date 3/22/2023

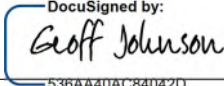
Signature  Title Authorized Person

EAF Mapper Summary Report

Wednesday, March 22, 2023 9:27 AM

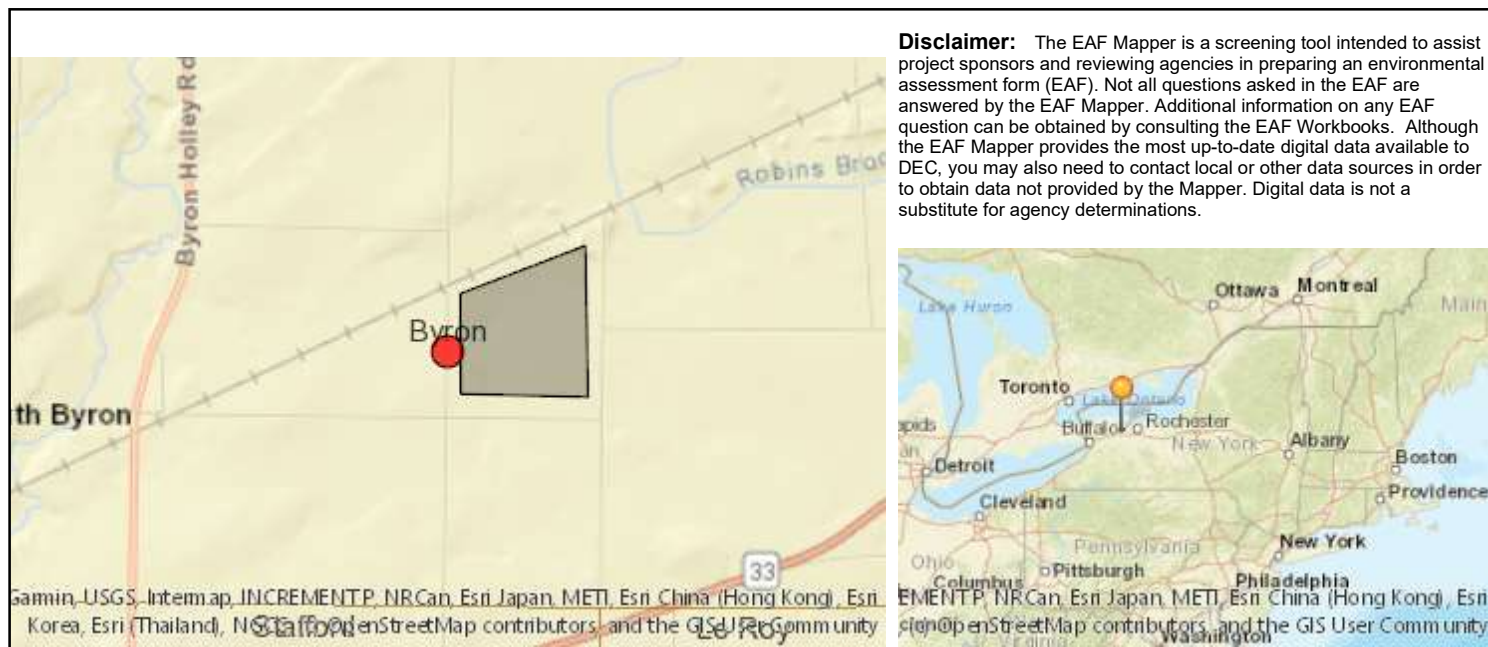

Disclaimer: The EAF Mapper is a screening tool intended to assist project sponsors and reviewing agencies in preparing an environmental assessment form (EAF). Not all questions asked in the EAF are answered by the EAF Mapper. Additional information on any EAF question can be obtained by consulting the EAF Workbooks. Although the EAF Mapper provides the most up-to-date digital data available to DEC, you may also need to contact local or other data sources in order to obtain data not provided by the Mapper. Digital data is not a substitute for agency determinations.

B.i.i [Coastal or Waterfront Area]	No
B.i.ii [Local Waterfront Revitalization Area]	No
C.2.b. [Special Planning District]	Digital mapping data are not available or are incomplete. Refer to EAF Workbook.
E.1.h [DEC Spills or Remediation Site - Potential Contamination History]	Digital mapping data are not available or are incomplete. Refer to EAF Workbook.
E.1.h.i [DEC Spills or Remediation Site - Listed]	Digital mapping data are not available or are incomplete. Refer to EAF Workbook.
E.1.h.i [DEC Spills or Remediation Site - Environmental Site Remediation Database]	Digital mapping data are not available or are incomplete. Refer to EAF Workbook.
E.1.h.iii [Within 2,000' of DEC Remediation Site]	No
E.2.g [Unique Geologic Features]	No
E.2.h.i [Surface Water Features]	Yes
E.2.h.ii [Surface Water Features]	Yes
E.2.h.iii [Surface Water Features]	Yes - Digital mapping information on local and federal wetlands and waterbodies is known to be incomplete. Refer to EAF Workbook.
E.2.h.iv [Surface Water Features - Stream Name]	821-40
E.2.h.iv [Surface Water Features - Stream Classification]	C
E.2.h.iv [Surface Water Features - Wetlands Name]	Federal Waters
E.2.h.v [Impaired Water Bodies]	No
E.2.i. [Floodway]	Digital mapping data are not available or are incomplete. Refer to EAF Workbook.
E.2.j. [100 Year Floodplain]	Digital mapping data are not available or are incomplete. Refer to EAF Workbook.

E.3.k. [500 Year Floodplain]	Digital mapping data are not available or are incomplete. Refer to EAF Workbook.
E.2.l. [Aquifers]	No
E.2.n. [Natural Communities]	No
E.2.o. [Endangered or Threatened Species]	No
E.2.p. [Rare Plants or Animals]	No
E.3.a. [Agricultural District]	Yes
E.3.a. [Agricultural District]	GENE004
E.3.c. [National Natural Landmark]	No
E.3.d [Critical Environmental Area]	No
E.3.e. [National or State Register of Historic Places or State Eligible Sites]	Digital mapping data are not available or are incomplete. Refer to EAF Workbook.
E.3.f. [Archeological Sites]	No
E.3.i. [Designated River Corridor]	No

EXHIBIT C. THREE LINE DIAGRAM



NO.	DATE	DESCRIPTION

LEATHERLEAF SOLAR, LLC
7501 IVISON RD.
BYRON, NY 14422

DATE: 03/17/22
DRAWN BY: RS
CHECKED BY:

PROJECT INFO:

SYSTEM SIZE:	INTERCONNECTION VOLTAGE:
AC SYSTEM RATING: 5 MW AC DC SYSTEM RATING: 6.5 MW DC	13.2 KV
UTILITY:	EQUIPMENT:
NATIONAL GRID	QUANTITY TYPE
	2 SMA SC 2800-UP-US INVERTER
APPLICANT:	2 2800 KVA YGΔ TRANSFORMER
LEATHERLEAF	11,622 BOVIET BMV7512M PV MODULES (OR EQUIVALENT)

GENERAL NOTES:

- ALL EQUIPMENT SHALL BE UL LISTED FOR USE IN SYSTEM CONFIGURATION.
- INSTALLATION SHALL COMPLY WITH THE LATEST VERSION OF NEC STANDARDS ADOPTED BY THE AUTHORITY HAVING JURISDICTION.
- DC ARRAY SYSTEM SIZE AND CONFIGURATION MAY VARY UPON FINAL DESIGN.
- MEDIUM VOLTAGE UTILITY INTERCONNECTION SHALL BE IN COMPLIANCE WITH UTILITY STANDARDS.
- NEUTRAL GROUNDING REACTOR SIZED PER IEEE P1547.8

SYMBOLS:

- CIRCUIT BREAKER
- DISCONNECT
- FUSE
- FUSED DISCONNECT
- SURGE ARRESTER

PRELIMINARY RECLOSER SETTINGS:

DEVICE	FUNCTION	PICKUP	CLEARING TIME	TIME DELAY
27-1	UNDER VOLTAGE	0.88VPU (100.8 V)	2.0 S	1.954S
27-2	UNDER VOLTAGE	0.5V PUI (67.5 V)	1.1 S	1.054S
59-1	OVER VOLTAGE	1.10V PUI (126.1 V)	2.0 S	1.954S
59-2	OVER VOLTAGE	1.20V PUI (137.5 V)	0.16 S	0.114S
81-O-1	OVER FREQUENCY	61.2 HZ	300 S	299.954S
81-O-2	OVER FREQUENCY	62.0 HZ	0.16 S	0.114S
81-U-1	UNDER FREQUENCY	58.5 HZ	300 S	299.954S
81-U-2	UNDER FREQUENCY	56.5 HZ	0.16 S	0.114S
51G	OVER CURRENT	1.2 x FLA PU (2.187A)	1.5 S	1.454S
51	OVER CURRENT	1.3 x FLA PU (2.369A)	1.15 S	1.104S
79	RE-CLOSING	N/A	N/A	300S

- RELAY SETTINGS ARE PRELIMINARY.
- RECLOSER CLEARING TIME IS 3.0 CYCLES (0.046S). CLEARING TIME SHALL BE CONSIDERED IN THE DEVICE SETTINGS.
- 79 ELEMENT IS SET TO CLOSE IN 300S AFTER VOLTAGE AND FREQUENCY RETURN TO THE RANGE DEFINED IN ESB 756 TABLE 7.8.3-1. VOLTAGE RANGE: 0.95PU (108.9V) TO 1.05 PU (120.3V), FREQUENCY RANGE: 59.5 TO 60.5 HZ.
- THE SAFE TRIP JUNCTION BOX WORKS WITH SEL651R 42-PIN TAVRIDA RECLOSER INTERFACE WITH POWER SUPPLY 120VAC OR 230VAC. RECLOSER FEATURES 12V, 26Ah STORAGE ENERGY TO TRIP ONCE EVEN IF MAIN POWER IS LOST. THE SEL-651R SHALL HAVE OUTPUT 201 PROGRAMMED FOR RELAY MALFUNCTION EVENT. THE SAFE TRIP JUNCTION BOX PROVIDES RECLOSER TRIPPING IN THE FOLLOWING CASES:
 - MALFUNCTION OF SEL-651R RELAY IF IT HAPPENS NOT LATER THAN 12 HOURS OF AC POWER SUPPLY LOSS.
 - DISCONNECT CABLE TNA_RecUNIT_Umbilical_22(12) FROM JUNCTION BOX OR SEL IF IT HAPPENS NOT LATER THAN 12 HOURS AFTER AC POWER SUPPLY LOSS.
- RELAY FAIL-SAFE TO TRIP AT A MAXIMUM OF 2 SECONDS FOLLOWING LOSS OF DC POWER AND OR HARDWARE FAILURE.
- RELAY VOLTAGE SETTINGS ARE BASED ON A 114.6V SECONDARY BASE, USING 66.5 PT RATIO FROM THE METER CLUSTER

PRELIMINARY INVERTER SETTINGS:

DEVICE	FUNCTION	PICKUP (630V)	TIME DELAY
27-1	UNDER VOLTAGE	0.88 V PU (554.4V)	2.0 S
27-2	UNDER VOLTAGE	0.5V PU (315V)	1.1 S
59-1	OVER VOLTAGE	1.10 V PU (693V)	2.0 S
59-2	OVER VOLTAGE	1.20 V PU (750V)	0.16 S
59-3	OVER VOLTAGE (TOV)	1.4V PU (882V)	1 ms
81-O-1	OVER FREQUENCY	61.2 HZ	300 S
81-O-2	OVER FREQUENCY	62.0 HZ	0.16 S
81-U-1	UNDER FREQUENCY	58.5 HZ	300 S
81-U-2	UNDER FREQUENCY	56.5 HZ	0.16 S

- INVERTER IS SET TO RECONNECT IN 300S AFTER VOLTAGE AND FREQUENCY RETURN TO THE RANGE DEFINED IN ESB 756 TABLE 7.8.3-1. VOLTAGE RANGE: 0.95 PU (598.5 V) TO 1.05 (661.5V) PU, FREQUENCY RANGE: 59.5 TO 60.5 HZ.

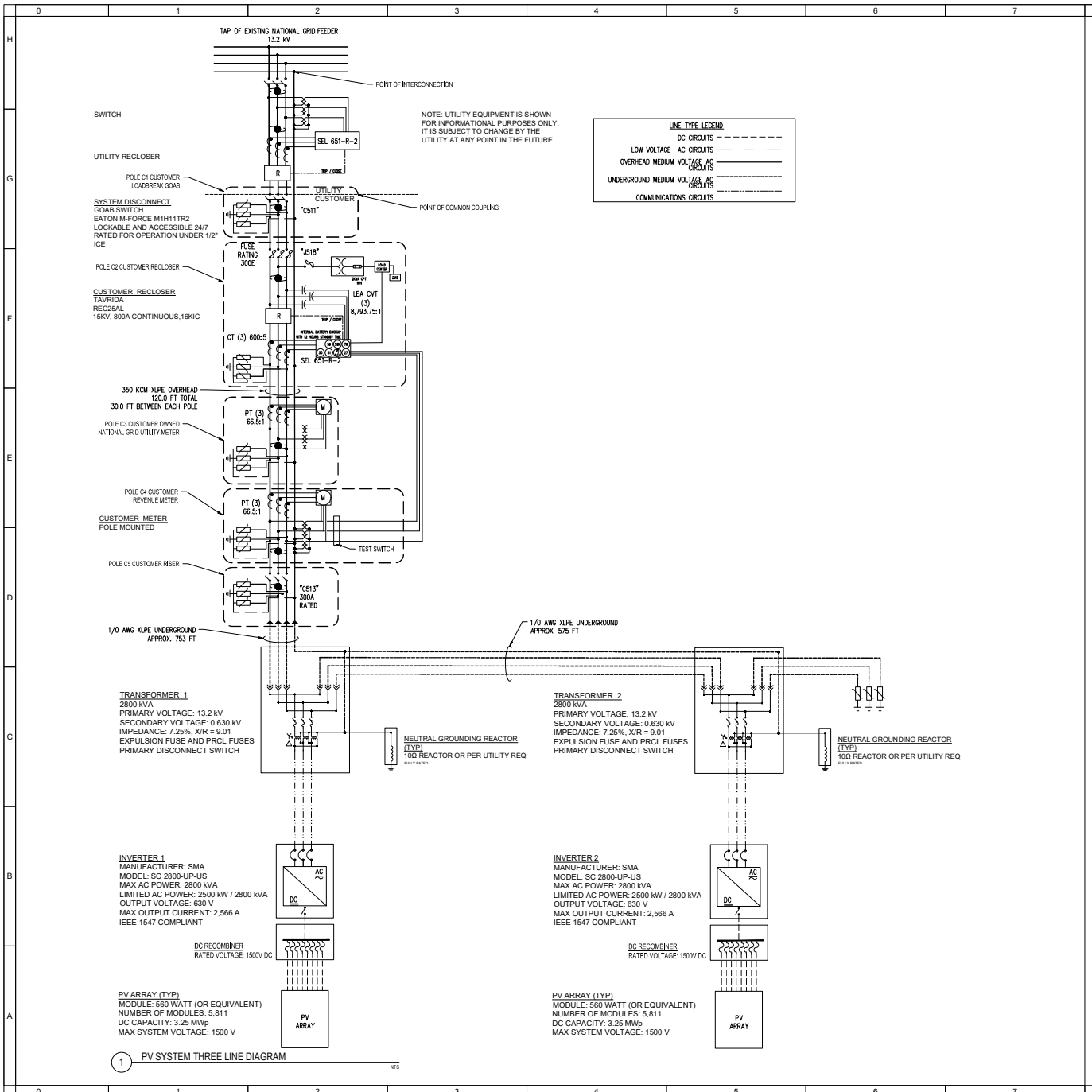

NOTE: UTILITY EQUIPMENT IS SHOWN FOR INFORMATIONAL PURPOSES ONLY. IT IS SUBJECT TO CHANGE BY THE UTILITY AT ANY POINT IN THE FUTURE.

LINE TYPE LEGEND

- DC CIRCUITS: - - - - -
- LOW VOLTAGE AC CIRCUITS: - · - · - · -
- OVERHEAD MEDIUM VOLTAGE AC CIRCUITS: ————
- UNDERGROUND MEDIUM VOLTAGE AC CIRCUITS: - - - - -
- COMMUNICATIONS CIRCUITS: - · - · - · -

0 1 2 3 4 5 6 7 8 9 10

H

G

F

E

D

C

B

A

EXHIBIT D. PRELIMINARY EQUIPMENT SPECIFICATIONS SHEET

PERFORMANCE 6 | 535-555

POWER RANGE: 535 – 555 W

The Performance 6 panel is engineered to meet the unique needs of solar power plants. Bifacial power generation and G12 (210mm) cell technology combine to maximise power density, while its framed glass/glass construction offers greater durability for extended panel life.

Backed by a comprehensive warranty and an estimated 35-year useful life,¹ Performance panels wrap conventional front contact cells with 35 years of materials, engineering and manufacturing expertise to mitigate the reliability challenges of Conventional Panel design.

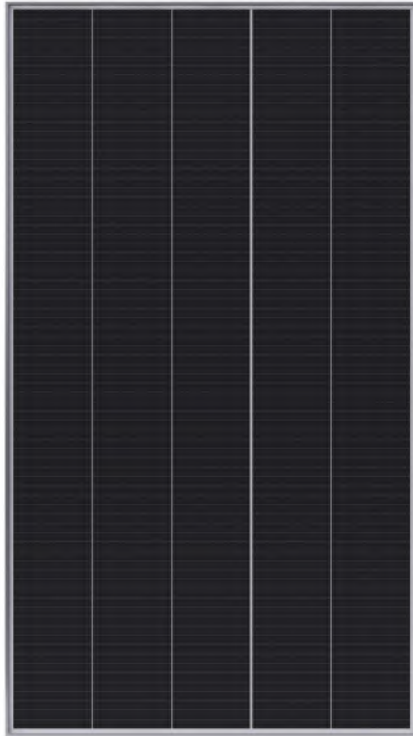

Engineered for Performance

- Smaller cells stay cooler when shaded, extending panel life³
- An advanced encapsulant minimizes degradation from environmental exposure
- Conductive adhesive defends against daily temperature swings
- Redundant cell connections create flexible paths for continuous electricity flow

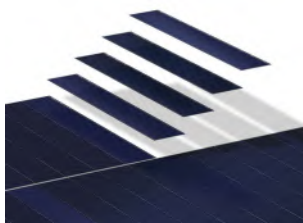

Durability that Translates to More Energy

Engineered to stand up to environmental stresses such as shading, daily temperature swings and high humidity, the Performance 6 is a high power panel uniquely suited for power plant EPCs and developers looking to maximize energy production.

A Track Record of Innovation Leadership

Performance panels represent the most deployed shingled cell panel in the industry—innovation protected by a growing portfolio of patents worldwide.²



6+ GW
Deployed



60+
Countries



90+
Patents

A Better Product. A Better Warranty.

The Performance 6 panel is backed by a 12-year product and 30-year power warranty.

• Year 1 Minimum Warranted Power Output	98.0%
• Maximum Annual Degradation	0.45%
• Year 30 Warranted Power Output	85.0%

Electrical Data, Front STC Characteristics⁴

Model	SPR-P6-555-UPP	SPR-P6-550-UPP	SPR-P6-545-UPP	SPR-P6-540-UPP	SPR-P6-535-UPP
Nominal Power (P _{nom}) ⁴	555 W	550 W	545 W	540 W	535 W
Power Tolerance	+3/0%	+3/0%	+3/0%	+3/0%	+3/0%
Efficiency	21.3%	21.1%	20.9%	20.7%	20.6%
Rated Voltage (V _{mpp})	40.0 V	39.7 V	39.5 V	39.3 V	39.0 V
Rated Current (I _{mpp})	13.89 A	13.85 A	13.80 A	13.76 A	13.71 A
Open-Circuit Voltage (V _{oc})	47.3 V	47.1 V	46.9 V	46.7 V	46.5 V
Short-Circuit Current (I _{sc})	14.73 A	14.68 A	14.64 A	14.59 A	14.54 A
Maximum System Voltage	1500 V UL				
Maximum Series Fuse	25 A				
Power Temp. Coef.	-0.34% / °C				
Voltage Temp. Coef.	-0.28% / °C				
Current Temp. Coef.	0.06% / °C				

Bifacial Characteristics

Bifaciality (φP _{max})	70% +/-10%				
P _{max} BiF05	583 W	578 W	572 W	567 W	562 W
I _{sc} BiF05	15.46 A	15.41 A	15.37 A	15.31 A	15.26 A
P _{max} BiF10	611 W	605 W	600 W	594 W	589 W
I _{sc} BiF10	16.20 A	16.14 A	16.10 A	16.04 A	15.99 A
P _{max} BiF20	666 W	660 W	654 W	648 W	642 W
I _{sc} BiF20	17.67 A	17.61 A	17.56 A	17.50 A	17.44 A

Tests And Certifications (Pending)

Standard Tests	UL1703
Quality Certs	ISO 9001:2008, ISO 14001:2004
EHS Compliance	OHSAS 18001:2007, Recycling Scheme
Ammonia Test	IEC 62716
Desert Test	MIL-STD-810G
Salt Spray Test	IEC 61701 (maximum severity)
LeTID Test ⁵	IEC 61215 (MQT 23.1 LeTID detection) draft standard
PID Test	IEC 62804
Available Listings ⁶	UL

Operating Condition And Mechanical Data

Temperature	-40°F to +185°F (-40°C to +85°C)
Impact Resistance	1 inch (25 mm) diameter hail at 52 mph (23 m/s)
Solar Cells	Monocrystalline PERC
Tempered Glass	High-transmission tempered anti-reflective
Junction Box	IP-68, Renhe ZJRH 05-8 or Zerun Z4S or Stäubli Evo2, 3 bypass diodes
Weight	71.4 lbs (32.4 kg)
Max. Load	Wind: 50 psf, 2400 Pa, 244 kg/m ² back Snow: 112 psf, 5400 Pa, 550 kg/m ² front
Frame	Class 2 silver anodized

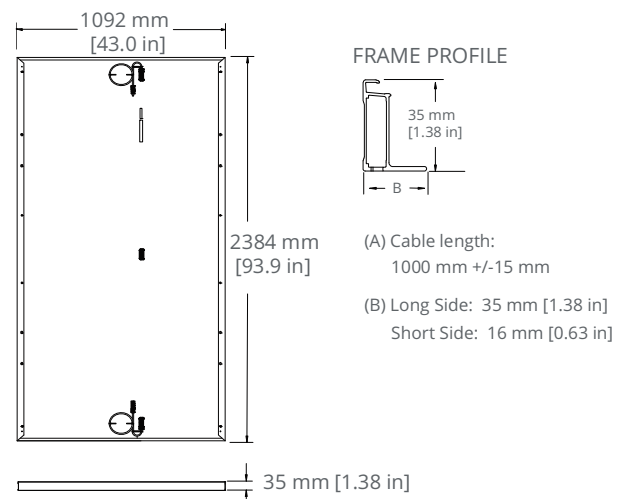

Please read the safety and installation guide.

- 1 Performance panels expected useful life of 35 years. Source: "P-Series Technology Technical Review," Leidos Independent Engineer Report. 2016.
- 2 Based on shipments as of Q2-2020.
- 3 Performance Series – Thermal Performance, Z.Campeau 2016.
- 4 Measured at Standard Test Conditions (STC): irradiance of 1000 W/m², AM 1.5, and cell temperature 25° C.
- 5 Fraunhofer CSP LID Sensitivity according to IEC 61215 (MQT 23.1 LeTID detection), 0.5% power loss at 700 hours.
6. Cert only covers front side performance.

Designed in the U.S.A.
Assembled in Mexico

Specifications included in this datasheet are subject to change without notice.

© 2021 Maxeon Solar Technologies, Ltd. All Rights Reserved. View warranty, patent and trademark information at maxeon.com/legal.

maxeon

538460 REV 0.12 / LTR_US
Publication Date: September 2021

SUNNY CENTRAL

2660 UP-US / 2800 UP-US / 2930 UP-US / 3060 UP-US



Efficient

- Up to 4 inverters can be transported in one standard shipping container
- Overdimensioning up to 150% is possible
- Full power at ambient temperatures of up to 35°C

Robust

- Intelligent air cooling system OptiCool for efficient cooling
- Suitable for outdoor use in all climatic ambient conditions worldwide

Flexible

- Conforms to all known grid requirements worldwide
- Q on demand
- Available as a single device or turnkey solution, including Medium Voltage Power Station

Easy to Use

- Improved DC connection area
- Connection area for customer equipment
- Integrated voltage support for internal and external loads

SUNNY CENTRAL

2660 UP-US / 2800 UP-US / 2930 UP-US / 3060 UP-US

The new Sunny Central: more power per cubic meter

With an output of up to 3060 kVA and system voltages of 1500 V DC, the SMA central inverter allows for more efficient system design and a reduction in specific costs for PV power plants. A separate voltage supply and additional space are available for the installation of customer equipment. True 1500 V technology and the intelligent cooling system OptiCool ensure smooth operation even in extreme ambient temperature as well as a long service life of 25 years.

SUNNY CENTRAL 2660 UP-US / 2800 UP-US

Technical data*	SC 2660 UP-US	SC 2800 UP-US
Input (DC)		
MPP voltage range V_{DC} (at 35 °C / at 50 °C)	880 to 1325 V / 1100 V	921 to 1325 V / 1100 V
Min. input voltage $V_{DC, min}$ / Start voltage $V_{DC, Start}$	849 V / 1030 V	891 V / 1071 V
Max. input voltage $V_{DC, max}$	1500 V	
Max. input current $I_{DC, max}$ / with DC coupling	3200 A / 4800 A	
Max. short-circuit current $I_{DC, sc}$	6400 A	
Number of DC inputs	24 double pole fused (32 single pole fused)	
Number of DC inputs with optional DC coupling of battery	18 double pole fused (36 single pole fused) for PV, 6 double pole fused for batteries	
Max. number of DC cables per DC input (for each polarity)	2 x 800 kcmil, 2 x 400 mm ²	
Integrated zone monitoring	○	
Available PV fuse sizes (per input)	200 A, 250 A, 315 A, 350 A, 400 A, 450 A, 500 A	
Available DC-DC converter fuse size (per input)	750 A	
Output (AC)		
Nominal AC power at $\cos \varphi = 1$ (at 35 °C / at 50 °C)	2667 kVA / 2400 kVA	2800 kVA / 2520 kVA
Nominal AC power at $\cos \varphi = 0.8$ (at 35 °C / at 50 °C)	2134 kW / 1920 kW	2240 kW / 2016 kW
Nominal AC current $I_{AC, nom}$ (at 35 °C / at 50 °C)	2566 A / 2309 A	
Max. total harmonic distortion	< 3% at nominal power	
Nominal AC voltage / nominal AC voltage range ^{1) 8)}	600 V / 480 V to 720 V	630 V / 504 V to 756 V
AC power frequency / range	50 Hz / 47 Hz to 53 Hz 60 Hz / 57 Hz to 63 Hz	
Min. short-circuit ratio at the AC terminals ⁹⁾	> 2	
Power factor at rated power / displacement power factor adjustable ^{8) 10)}	1 / 0.8 overexcited to 0.8 underexcited	
Efficiency		
Max. efficiency ²⁾ / European efficiency ²⁾ / CEC efficiency ³⁾	98.7%* / 98.6%* / 98.5%*	98.7%* / 98.6%* / 98.5%*
Protective Devices		
Input-side disconnection point	DC load break switch	
Output-side disconnection point	AC circuit breaker	
DC overvoltage protection	Surge arrester, type I	
AC overvoltage protection (optional)	Surge arrester, class I	
Lightning protection (according to IEC 62305-1)	Lightning Protection Level III	
Ground-fault monitoring / remote ground-fault monitoring	○ / ○	
Insulation monitoring	○	
Degree of protection	NEMA 3R	
General Data		
Dimensions (W / H / D)	2815 / 2318 / 1588 mm (110.8 / 91.3 / 62.5 inch)	
Weight	< 3400 kg / < 7500 lb	
Self-consumption (max. ⁴⁾ / partial load ⁵⁾ / average ⁶⁾	< 8100 W / < 1800 W / < 2000 W	
Self-consumption (standby)	< 370 W	
Internal auxiliary power supply	○ Integrated 8.4 kVA transformer	
Operating temperature range ⁸⁾	-25 °C to 60 °C / -13 °F to 140 °F	
Noise emission ⁷⁾	67.0 dB(A)*	
Temperature range (standby)	-40 °C to 60 °C / -40 °F to 140 °F	
Temperature range (storage)	-40 °C to 70 °C / -40 °F to 158 °F	
Max. permissible value for relative humidity (condensing / non-condensing)	95% to 100% (2 month/year) / 0% to 95%	
Maximum operating altitude above MSL ⁸⁾ 1000 m / 2000 m	● / ○ (earlier temperature-dependent derating)	
Fresh air consumption	6500 m ³ /h	
Features		
DC connection	Terminal lug on each input (without fuse)	
AC connection	With busbar system (three busbars, one per line conductor)	
Communication	Ethernet, Modbus Master, Modbus Slave	
Communication with SMA string monitor (transmission medium)	Modbus TCP / Ethernet (FO MM, Cat-5)	
Enclosure / roof color	RAL 9016 / RAL 7004	
Supply transformer for external loads	○ (2.5 kVA)	
Standards and directives complied with	UL 62109-1, UL 1741 (Chapter 31, CDR 61), UL 1741-SA, UL 1998, IEEE 1547, MIL-STD-810G	
EMC standards	FCC Part 15 Class A	
Quality standards and directives complied with	VDI/VDE 2862 page 2, DIN EN ISO 9001	
● Standard features ○ Optional * preliminary		

1) At nominal AC voltage, nominal AC power decreases in the same proportion

2) Efficiency measured without internal power supply

3) Efficiency measured with internal power supply

4) Self-consumption at rated operation

5) Self-consumption at < 75% P_n at 25 °C

6) Self-consumption averaged out from 5% to 100% P_n at 25 °C

7) Sound pressure level at a distance of 10 m

8) Values apply only to inverters. Permissible values for SMA MV solutions from SMA can be found in the corresponding data sheets.

9) A short-circuit ratio of < 2 requires a special approval from SMA

10) Depending on the DC voltage

SUNNY CENTRAL 2930 UP-US / 3060 UP-US

Technical data*	SC 2930 UP-US	SC 3060 UP-US
Input (DC)		
MPP voltage range V_{DC} (at 35 °C / at 50 °C)	962 to 1325 V / 1100 V	1003 to 1325 V / 1100 V
Min. input voltage $V_{DC, min}$ / Start voltage $V_{DC, Start}$	934 V / 1112 V	976 V / 1153 V
Max. input voltage $V_{DC, max}$	1500 V	
Max. input current $I_{DC, max}$ / with DC coupling	3200 A / 4800 A	
Max. short-circuit current $I_{DC, sc}$	6400 A	
Number of DC inputs	24 double pole fused (32 single pole fused)	
Number of DC inputs with optional DC coupling of battery	18 double pole fused (36 single pole fused) for PV, 6 double pole fused for batteries	
Max. number of DC cables per DC input (for each polarity)	2 x 800 kcmil, 2 x 400 mm ²	
Integrated zone monitoring	○	
Available PV fuse sizes (per input)	200 A, 250 A, 315 A, 350 A, 400 A, 450 A, 500 A	
Available DC-DC converter fuse size (per input)	750 A	
Output (AC)		
Nominal AC power at $\cos \varphi = 1$ (at 35 °C / at 50 °C)	2933 kVA / 2640 kVA	3067 kVA / 2760 kVA
Nominal AC power at $\cos \varphi = 0.8$ (at 35 °C / at 50 °C)	2346 kW / 2112 kW	2454 kW / 2208 kW
Nominal AC current $I_{AC, nom}$ (at 35 °C / at 50 °C)	2566 A / 2309 A	
Max. total harmonic distortion	< 3% at nominal power	
Nominal AC voltage / nominal AC voltage range ^{1) 8)}	660 V / 528 V to 759 V	690 V / 552 V to 759 V
AC power frequency / range	50 Hz / 47 Hz to 53 Hz 60 Hz / 57 Hz to 63 Hz	
Min. short-circuit ratio at the AC terminals ⁹⁾	> 2	
Power factor at rated power / displacement power factor adjustable ^{8) 10)}	1 / 0.8 overexcited to 0.8 underexcited	
Efficiency		
Max. efficiency ²⁾ / European efficiency ²⁾ / CEC efficiency ³⁾	98.7%* / 98.6%* / 98.5%*	98.7%* / 98.6%* / 98.5%*
Protective Devices		
Input-side disconnection point	DC load break switch	
Output-side disconnection point	AC circuit breaker	
DC overvoltage protection	Surge arrester, type I	
AC overvoltage protection (optional)	Surge arrester, class I	
Lightning protection (according to IEC 62305-1)	Lightning Protection Level III	
Ground-fault monitoring / remote ground-fault monitoring	○ / ○	
Insulation monitoring	○	
Degree of protection	NEMA 3R	
General Data		
Dimensions (W / H / D)	2815 / 2318 / 1588 mm (110.8 / 91.3 / 62.5 inch)	
Weight	< 3400 kg / < 7500 lb	
Self-consumption (max. ⁴⁾ / partial load ⁵⁾ / average ⁶⁾)	< 8100 W / < 1800 W / < 2000 W	
Self-consumption (standby)	< 370 W	
Internal auxiliary power supply	○ Integrated 8.4 kVA transformer	
Operating temperature range ⁸⁾	-25 °C to 60 °C / -13 °F to 140 °F	
Noise emission ⁷⁾	67.0 dB(A)*	
Temperature range (standby)	-40 °C to 60 °C / -40 °F to 140 °F	
Temperature range (storage)	-40 °C to 70 °C / -40 °F to 158 °F	
Max. permissible value for relative humidity (condensing / non-condensing)	95% to 100% (2 month/year) / 0% to 95%	
Maximum operating altitude above MSL ⁸⁾ 1000 m / 2000 m	● / ○ (earlier temperature-dependent derating)	
Fresh air consumption	6500 m ³ /h	
Features		
DC connection	Terminal lug on each input (without fuse)	
AC connection	With busbar system (three busbars, one per line conductor)	
Communication	Ethernet, Modbus Master, Modbus Slave	
Communication with SMA string monitor (transmission medium)	Modbus TCP / Ethernet (FO MM, Cat-5)	
Enclosure / roof color	RAL 9016 / RAL 7004	
Supply transformer for external loads	○ (2.5 kVA)	
Standards and directives complied with	UL 62109-1, UL 1741 (Chapter 31, CDR 61), UL 1741-SA, UL 1998 IEEE 1547, MIL-STD-810G	
EMC standards	FCC Part 15 Class A	
Quality standards and directives complied with	VDI/VDE 2862 page 2, DIN EN ISO 9001	
● Standard features ○ Optional * preliminary		

1) At nominal AC voltage, nominal AC power decreases in the same proportion

2) Efficiency measured without internal power supply

3) Efficiency measured with internal power supply

4) Self-consumption at rated operation

5) Self-consumption at < 75% P_n at 25 °C

6) Self-consumption averaged out from 5% to 100% P_n at 25 °C

7) Sound pressure level at a distance of 10 m

8) Values apply only to inverters. Permissible values for SMA MV solutions from SMA can be found in the corresponding data sheets.

9) A short-circuit ratio of < 2 requires a special approval from SMA

10) Depending on the DC voltage

SYSTEM DIAGRAM

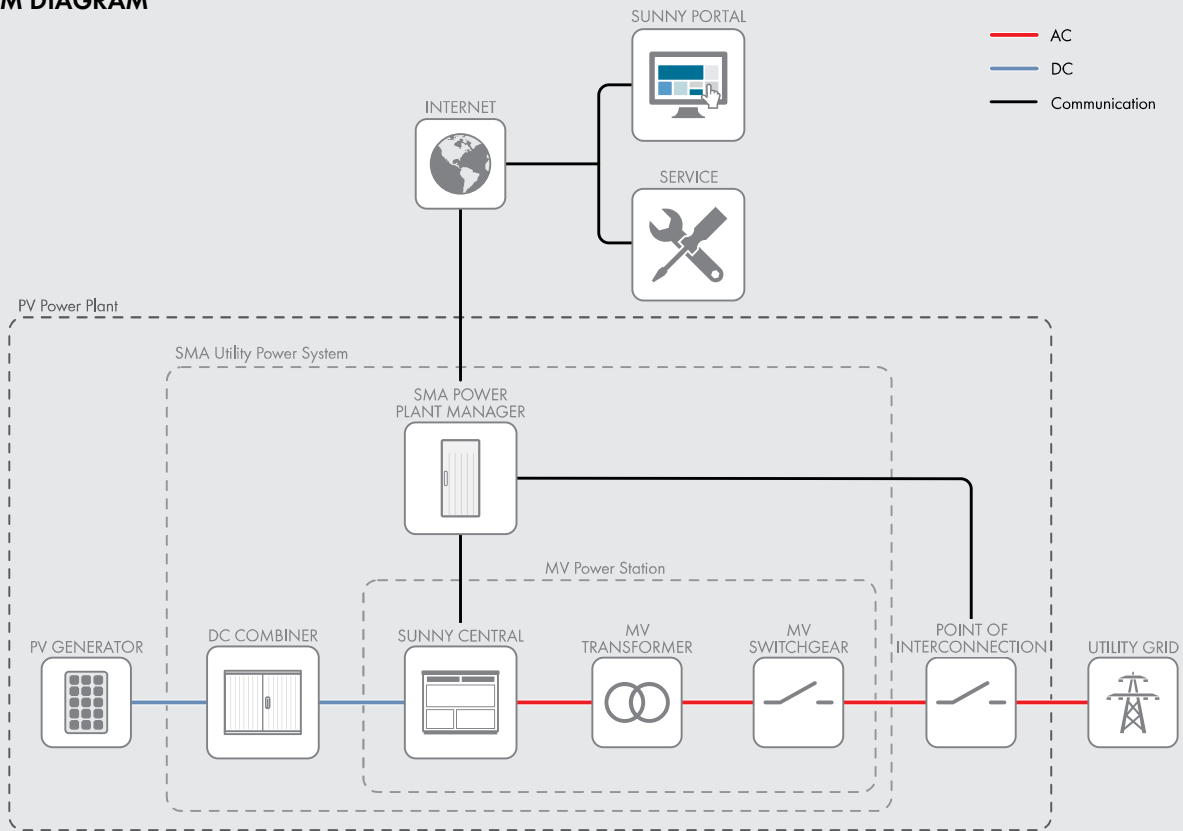

TEMPERATURE BEHAVIOR (at 1000 m)

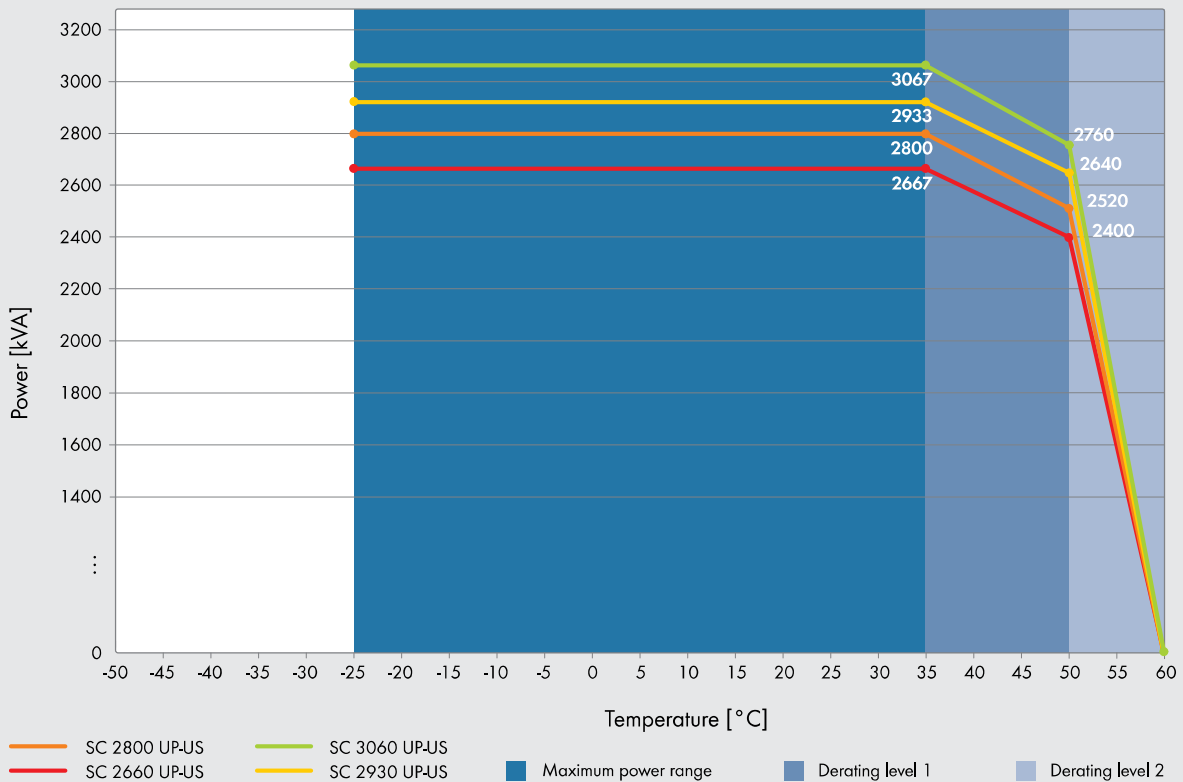

SC23XXUPUSDS-en-17 All products and services described and all technical data are subject to change, even for reasons of country-specific deviations, at any time without notice. SMA assumes no liability for typographical or other errors. For current information, please see www.SMA.Solar.com.

MECHANICAL SYSTEMS OVERVIEW

COMPONENT DATA SHEET

With over 5GW of solar trackers delivered on five continents, NEXTracker's NX Horizon™ is the world's leading single-axis tracker. The NX Horizon is a self-powered, decentralized tracking system where each row is independent of one another - an industry first. Prior to this pioneering innovation, single-axis trackers included a drive shaft connecting each row, which impeded overall operations and maintenance of solar power plants. For NX Horizon, each row is driven by a brushless DC motor coupled to a slew gear. Power for the motor is provided by our patent-pending Self-Powered Controller (SPC) and a dedicated PV module.

BRUSHLESS DC MOTOR SPECIFICATIONS

MECHANICAL		POWER RATINGS	
Protection Class	IP 65	Nominal Voltage	24 V DC
Isolation Class	EN62114 (120C)	Motor Continuous Current (85C)	< 6.25 A
Certification	UL 1004-1	No load Current at 24VDC (85C)	< 1 A
Operating Temperature	-40°C to 85°C	Max Power at Rated Torque	150 W
Motor Type	Brushless		
Weight	1.7kg	OUTPUT	
Relative Humidity	0-95%	Rated Gear Output Torque (1 hr. continuous)	150 N-m



SLEW GEAR SPECIFICATIONS

MECHANICAL

Protection Class	IP 55 per IEC60529
Ambient Temp. Range	-40C to 60C
Housing Material	Ductile Iron
Rotation Range	±65°
Weight	77.5kg

LOAD RATINGS

Normal Output Torque, min	± 2000 N-m
High Output Torque, min	± 5000 N-m

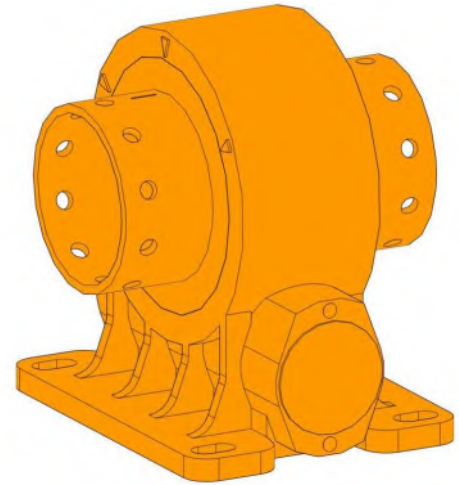

SLEW GEAR

The NX Horizon slew gear is a single stage, worm gear speed reducer. The slew gear is designed to adjust the tracker tilt position to follow the sun each day, as well as hold the tracker position fixed during periods of wind stow. The brushless motor is directly coupled to the input worm shaft of the slew gear, with the tracker torque tubes permanently connected to the output collars. The slew gear is sealed and requires no scheduled maintenance for the life of the product.



NX Horizon Solar Tracker
UL 2703 & 3703 Certified

NX HORIZON BACKUP BATTERY

COMPONENT DATA SHEET

With over 5 GW of solar trackers delivered on five continents, NEXTracker's NX Horizon™ is the world's leading single-axis tracker. Unique to our tracking technology is a patent-pending self-powered control system. Each Self-Powered Controller (SPC) contains an uninterruptible power supply (UPS) with an integrated, low-cost, off-the-shelf lithium-ion battery pack. A small, dedicated PV panel powers the controller and motor for each individual tracker row, eliminating the need for power wiring. The battery in the controller is used for backup only during low-light conditions and when safety stop is triggered. The battery is capable of driving the row uninterrupted for three days without PV power.

BACKUP BATTERY SPECIFICATIONS

ELECTRICAL RATING

Maximum charge current	2 A
Maximum discharge current (5 minutes)	11.5 A
Nominal voltage	14.5 V
Maximum capacity	4 Ah
Service life	10 years

MECHANICAL

SPC enclosure rating	NEMA 4X/IP65
Max. dimensions, mm (L x W x D)	68 x 92 x 45
Weight	< 3 lb

ENVIRONMENT

Charge temperature	0°C to 60°C
Discharge temperature	-30°C to 60°C
Storage temperature	0°C to 40°C

COMPLIANCE

IEC 62133, CB Scheme
UN38.3
UL 2054

LITHIUM ION BATTERY

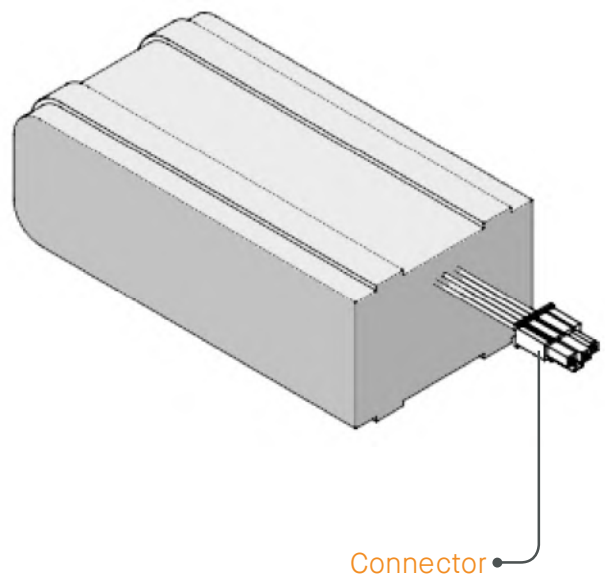



NX Horizon 2 Control System

Component Data Sheet

Control System Overview

With over 50+ GW of solar trackers delivered on six continents, Nextracker's NX Horizon™ 2 is the world's leading single-axis tracker. NX Horizon 2 includes a comprehensive communications and control system for maximum tracker accuracy and system reliability. This system consists of three types of control units, all networked together via ZigBee® wireless mesh communications.

Self-Powered Controller

Our patent-pending Self-Powered Controller (SPC) is mounted on each tracker row and autonomously commands the tracker to follow the sun throughout the day. Location, time, and tracker angle data ensure effective tracking accuracy. The SPC is powered by a small, dedicated PV panel and includes a backup battery¹ to eliminate the need for any tracker power wiring. All SPCs communicate over a ZigBee wireless mesh network for monitoring and global control functions.

Network Control Unit

A Network Control Unit (NCU) aggregates communication and control for up to 100 SPCs via the same ZigBee network. Each NCU monitors real-time SPC parameters and issues global commands to its associated SPCs. During wind or snow events, stowing commands are generated and issued automatically based on real-time data from

Weather Stations located on-site. Manual operator-generated commands are available via a small control board on the NCU.

Each NCU is accessible via a Modbus interface for SCADA integration. NCUs are typically located at inverter pads with other electrical equipment to easily connect to the required AC power. As with the SPCs, a backup battery¹ is built into each NCU unit.

Self-Powered NCU

Also available is an optional Self-Powered NCU configuration comprising a small solar module and mounting kit. This Self-Powered NCU allows tracker commissioning and functional testing to be completed earlier than typical in the construction schedule and adds considerable flexibility to project execution. As with the standard NCU, the intention is to connect the NCU to AC power, once available, for added reliability. The Self-Powered NCU requires an Ethernet connection to transmit data to and from the project site.

1. A backup battery at full charge can provide power for 3 consecutive days of low irradiance and low temperature conditions.

Weather Station

A Weather Station measures real-time wind speed and snow depth and reports this data to the NCUs over the ZigBee network. When conditions warrant, the NCUs will propagate a stowing command out to their associated SPCs within seconds. Like the SPCs, each Weather Station is powered by a small, dedicated PV panel and includes a backup battery¹ eliminating the need for power wiring. The quantity and location of Weather Stations is defined on a per project basis.

1. A backup battery at full charge can provide power for 3 consecutive days of low irradiance and low temperature conditions.

Self-Powered Controller Specifications (Gen 2)

INPUT	
Max PV input power	135W
Max PV input voltage	30V _{dc}
Max PV input current	3.5A
MPPT voltage range	16V to 27V
Battery voltage	Nominal: 14.5V Range: 12V to 16V
MECHANICAL	
Enclosure rating	NEMA 4X / IP65
Dimensions (L x W x D)	355 mm x 203 mm x 101 mm (14" x 8" x 4")
Weight	<4 kg (<9 lbs.)
Enclosure Material	Polymer
EMI compliance	FCC Part 15 Subpart B EN 55022: 2010 AS/NZS CISPR
Safety compliance	UL 3703 in USA
OPERATING PERFORMANCE	
Standby consumption	<0.5W

OUTPUT	
Rated power	150W
Motor voltage	Nominal: 24V Range: 0V to 24V
Motor typical operating current	1.0A to 2.0A
Motor peak current	10A
ENVIRONMENT	
Operating temperature	-30°C to 55°C (-22°F to 131°F) -40°C to 55°C (-40°F to 131°F) with continuous external AC power
Storage temperature	-10°C to 45°C (14°F to 113°F)
Relative humidity	0 to 95%
BACKUP BATTERY	
Battery technology	Lithium ion
Expected battery life	10+ years
Backup storage capacity, extreme low irradiance conditions	3 days
COMMUNICATIONS	
Interface to NCU	ZigBee (2.4 GHz)

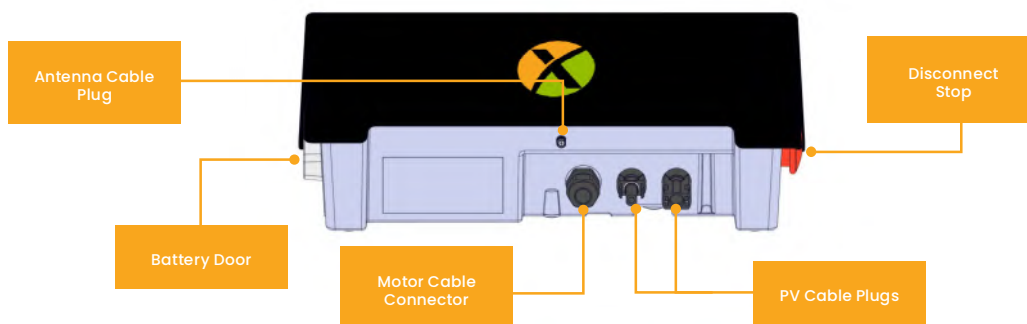

Weather Station Controller Specifications

INPUT	
Max PV input power	70W
Max PV input voltage	30V _{dc}
Max PV input current	3A
MPPT voltage range	10V to 25V
Battery voltage (nominal/range)	Nominal: 14.5V Range: 12V to 16V
MECHANICAL	
Enclosure rating	NEMA 4X / IP65
Dimensions (L x W x D)	355 mm x 203 mm x 101 mm (14" x 8" x 4")
Weight	<4 kg (<9 lbs)
COMMUNICATIONS	
Interface to NCU	ZigBee (2.4 GHz)

WEATHER STATION SENSORS	
Wind	Novalynx Wind Sonic 65
Snow/Flood	Novalynx 260-700
ENVIRONMENT	
Operating temperature, standard	0°C to 55°C (32°F to 131°F)
Operating temperature	-30°C to 55°C (-22°F to 131°F)
	-40°C to 55°C (-40°F to 131°F) with continuous external AC power
Storage temperature	-10°C to 45°C (14°F to 113°F)
Relative Humidity	0 to 95%
BACKUP BATTERY	
Battery technology	Lithium ion
Expected battery life	10+ years
Backup storage capacity	3 days minimum

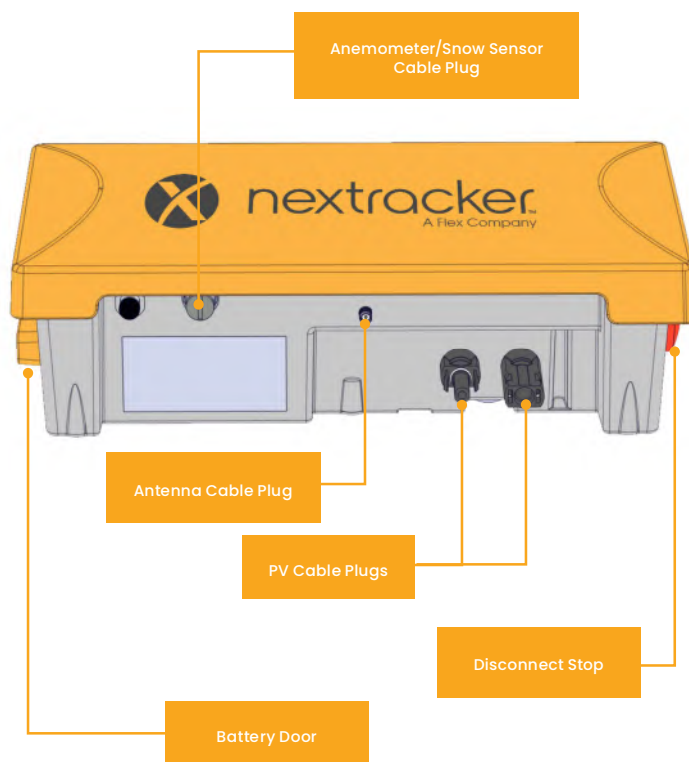
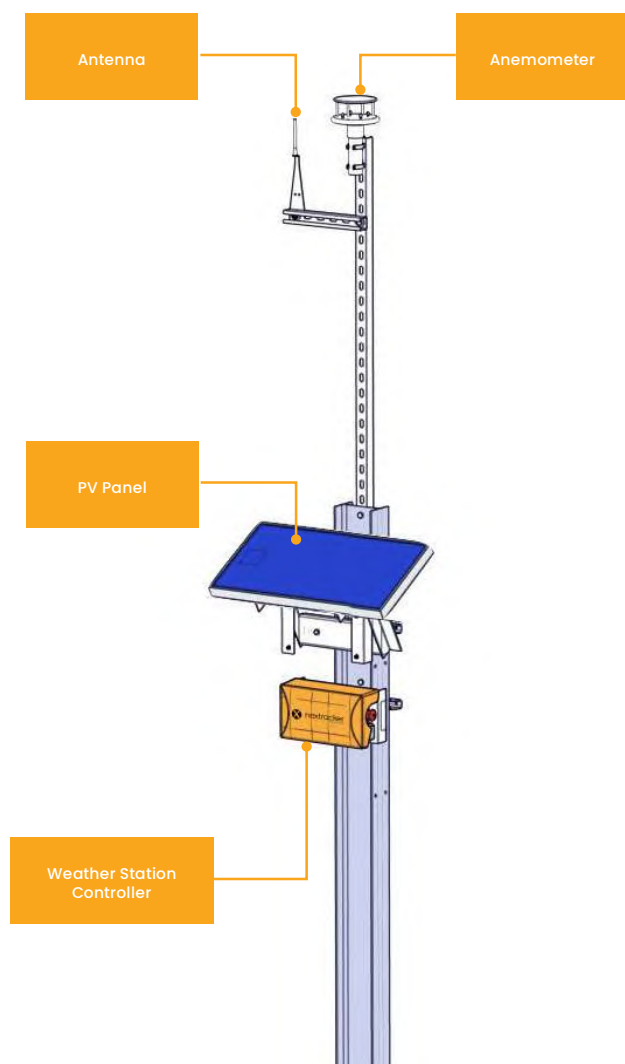

Network Control Unit Specifications

INPUT		MECHANICAL	
AC input voltage	100VAC to 265VAC	Enclosure rating	NEMA 4X
Operational power consumption	<10W	Dimensions (L x W x D)	491 mm x 452 mm x 200 mm (19" x 18" x 8")
Min. overcurrent device rating	2A	Weight	<9 kg (<20 lbs)
HARDWARE		COMMUNICATIONS	
CPU (Processor)	Cortex A8	Remote interface	ZigBee (2.4 GHz)
Onboard storage	4GB	Digital control panel	<ul style="list-style-type: none"> - Auto, Manual & Wash Positioning - Command Tracker to Any Angle - Functional System Testing - NCU Parameter Setting
Additional storage option	SD slot	Network interface	Ethernet RJ45
Onboard screen	VFD		
BACKUP BATTERY		ENVIRONMENT	
Battery technology	Lithium Ion	Operating temperature	-30°C to 55°C (-22°F to 131°F)
Expected battery life	10+ years		-40°C to 55°C (-40°F to 131°F) with continuous external AC power
Shelf Life (in storage)	3 months	Storage temperature	-10°C to 45°C (14°F to 113°F)
		Relative humidity	0 to 95%

Network Control Unit



EXHIBIT E. SPECIAL USE PERMIT APPLICATION

TOWN OF BYRON

APPLICATION TO THE PLANNING BOARD

Special Use Permit

Special Use Number : _____

Date : _____

OWNER

Name : Dean Ivison
Address : 7412 Coward Rd. Byron NY
14422
Telephone # : 585 414 3432

APPLICANT (If other than owner)

Name : Leather leaf Solar LLC
Address : PO Box 173 Latham NY
12110
Telephone # : 8282694446

- Request to the Planning Board to overturn the Zoning Enforcement Officer's decision to DENY GRANT an application for a Zoning Permit Application Number N/A Dated N/A.
- APPLICATION FOR : Special Use Permit Other Site Plan _____
Please Specify
- Address of Project Site : 7501 Ivison Rd. Byron NY 14422
Tax Map Number : 9.~1~7.113 Zoning District : Agricultural Residential
- Has a previous appeal been filed pertaining to this parcel ? No
Yes If yes, list Appeal No. _____ Date _____ Purpose of Request : _____
- Justification for Request : General Response Requirement for Tier 4 Solar Energy System in AR Agricultural Residential District.

 A more SPECIFIC RESPONSE should accompany this application on separate sheet(s) of paper. Address each of the statements listed on the back of the PINK sheet which pertain to your specific appeal.

The Applicant shall submit with this request, appropriate supporting materials including, but not limited to, site plans, elevations, traffic circulation diagrams, neighborhood land use maps and any other material that will assist the Board in making a determination regarding this request.

CERTIFICATION : I hereby certify that I have read and examined this application and supporting attachments and know the same to be true and correct. All provisions of laws and ordinances covering this type of work or use will be complied with whether specified herein or not. The granting of an appeal does not presume to give authority to violate or cancel the provisions of any other state or local ordinance or law regarding construction or performance of construction and/or use.

Groff Johnson 3/21/2023

Dean Ivison 3/20/2023

Applicant's Signature

Date:

Owner's Signature (if other than applicant)

Date:

PROVISIONS of ZONING LAW for SPECIAL USE:

- Article _____ Section _____
Subsection _____ Paragraph _____
state reason; _____
- Table I or II - state reason; _____

FEE COLLECTED : Check # _____

Special Use Fee \$ _____

Public Hearing Fee \$ _____

TOTAL FEE \$ _____

Signature - Zoning Enforcement Officer

Date

COPY DISTRIBUTION : White - Z.E.O.

Yellow - PLANNING BOARD

Pink - APPLICANT

OFFICE USE ONLY

EXHIBIT F. O&M AND VEGETATION MANAGEMENT PLAN

OPERATION AND MAINTENANCE PLAN

MAINTENANCE SERVICES FOR LEATHERLEAF SOLAR, LLC

During the term, Leatherleaf Solar, LLC (“Project Owner”) shall procure the services at the frequency indicated below, in accordance with the terms and conditions of a Operations and Maintenance Agreement with a Provider. It is expected that the Provider shall exert best efforts to note items of concern outside the scope of scheduled visits; inspecting and assessing items that seem to be problematic even if not part of the scheduled visits and later discussing with the owner to seek remedy.

Item #	Service	Service Description	Frequency
1. Monitoring, Reporting, and Inventory			
1.1	Active Site Monitoring	Monitor inverters and meter output data for issues and alarms.	Daily
1.2	Annual Maintenance Plan	Provision of Annual Maintenance Plan, including baseline schedule for all maintenance services contemplated to occur in such year	Annually, by November 1 of each calendar year during the Term
1.3	Monthly Reporting	Provide monthly operating report for the projects including a summary of (i) operations; (ii) weather data, power and environmental attributes; (iii) Project performance; (iv) reports of any environmental or site disturbances; (v) safety/accident reports; (vi) Non-Covered Services; (vii) maintenance and inspection reporting; and (viii) any scheduled or recommended maintenance for the upcoming month.	Monthly, by the 15th day of the following month
1.4	Annual Reporting	Provide annual maintenance/inspection reports for the Project for the preceding calendar year	Annually, by February 1 of each calendar year during the Term
1.5	Emergency Services and Incident Reporting	Provide written report (in .pdf format) on any event involving Emergency Services, personnel injury associated with the Projects, or material damage to any Project or any part thereof.	No later than five (5) business days after the occurrence, or immediately for OSHA recordable events, but no later than 24 hours after obtaining knowledge of the event.

Item #	Service	Service Description	Frequency
1.6	Security Incident Reporting	Notify Project Owner following provider receiving information indicative of a security issue on site	Immediately, but no later than 24 hours after obtaining knowledge of the event.
1.7	Maintain Spare Parts	Store, maintain, and replenish spare parts inventory at Project Owner's expense. Inventory will be stored, at Provider's option either on-site in an O&M storage structure or off-site at a centralized storage facility or warehouse.	As Needed
2. Site Property Inspection/Maintenance			
2.1	Vegetation Management	Maintain vegetation and debris removal/control and landscaping, for all property within the fence line and all property immediately surrounding fencing up to the road frontage, specifically ensuring vegetation does not encroach on modules. So long as Project Owner elects to maintain the Project as pollinator-friendly habitat, Provider will comply with and follow the Pollinator Vegetation Management Plan attached as Appendix I to this O&M Plan (as Provider may reasonably update from time to time and upon reasonable prior written notice to Project Owner).	Approximately 4X per year, unless otherwise stated in Appendix I.
2.2	Perimeter and Fence Inspection	Inspect all fencing for signs of damage, intrusion, and overgrowth of vegetation. Inspect signage to ensure all originally installed signs are present and legible	2 X per year
2.3	Roads	Inspect all roads for soil erosion concerns.	2 X per year
2.4	Site Security Systems	Inspect security systems (if installed) for proper operation according to original security plan and design. Inspect entire site for general vandalism or other signs of security related issues.	2 X per year
3. DC Systems			
3.1	Racking Inspection	Inspect all racking, racking mounts and conduits on racking for damage, corrosion, settling and stability	1 X per year
3.2	Module Inspections	Visually inspect a 25% sampling of modules for soiling, breakage, delamination, discoloring and hot spots (only via aerial thermal audits). Inspections may be done either on the ground or via aerial visual analysis and aerial thermal imaging. If systemic issues are identified, notify Project Owner and propose a corrective action plan to be implemented as needed.	1 X per year

Item #	Service	Service Description	Frequency
3.3	Broken Module Replacement	Replace modules that have previously been identified as broken (within reason) or identified as broken at the time of inspection. The cost of replacement modules (either for immediate use or to replenish spare parts) will be paid for by Project Owner as needed. The procurement of replacement modules is conditional to Project Owner approval.	As Needed
3.4	Wire Inspection	Visually inspect for proper wire management and any possible damage on exposed conductors.	2 X per year
3.5	Combiner Box and Re-Combiner Inspections	Electrical/mechanical inspection of combiners & disconnects. Visually inspect bonding bushings and grounding, check for wire damage especially at entrance/exit locations, terminal corrosion, any discoloration, and inspect fuses for proper functionality. Remove insects/pest debris from all enclosures.	2 X per year
3.6	Combiner Box and Re-Combiner Torque Inspections	Confirm and correct terminal torque settings for both sides of all fuse holders, grounded (negative) terminal bar, grounding bar, PV output circuit and DC Disconnects.	1 X per year
4. AC Systems			
4.1	Inverters	Perform annual inverter preventative maintenance work for all inverters per manufacturer's recommendations and manufacturer's warranty requirements.	Per Manufacturer's Recommendations and Manufacturer's Warranty Requirements
4.2	Inverter Air Filters and Transformer heat sinks	Inspect inverter air-filters and heat sinks, and clean or replace air filters if necessary.	2 X per year or Per Manufacturers Recommendations, whichever is more frequent.
4.3	Transformers	Visually inspect and clean all transformers per manufacturer recommendations, including but not limited to oil level measurement and clearing heat sink of debris.	1 X per year
4.4	AC Disconnect (if applicable)	Inspection of latches and seals on enclosure, verify proper operation of disconnect, visually inspect terminations and confirm and correct terminal torque settings. Check for signs of arcing.	1 X per year
5. DAS/SCADA Inspections			

Item #	Service	Service Description	Frequency
5.1	General DAS Inspection	Perform monitoring system maintenance per manufacturer's specifications; verify orientation and attachment of pyranometers and module temperature sensors and MET station and verify back up power supply functionality.	1 X per year
5.2	Pyranometers	Clean pyranometer domes with a soft cloth.	All scheduled & unscheduled site visits
5.3	Pyranometer Calibration	Coordinate with Project Owner to cause calibration of pyranometers per manufacturer's specifications.	Per manufacturer specifications
5.4	Data/Instrument Accuracy and Communications Verification	Test MET station sensors (GHI and POA pyranometers, ambient temperature, back-of-module, anemometer, Revenue Grade Meter (including current transducers), and inverter direct	1 X per year
6. Testing			
6.1	IV Curve String Testing or Module Level Thermal Audits	100% IV Curve Testing on strings, or 100% Module Level Thermal Audits	1 X per year
6.2	Thermal Imaging	Thermal imaging of all: overcurrent protection devices (OCPD) and bolted electrical connections including terminations in combiners and all disconnects, inverters and transformers	1 X per year
6.3	Transformer Oil Testing	Conduct transformer oil sampling and testing per nationally and/or internationally recognized testing standards	1 X per two years
6.4	Point-to-Point Testing	For 5% random sampling of combiner boxes, inspect grounding from modules & rack to combiners for wear, corrosion, and secure connections, and test the point-to-point resistance between modules, rack and EGC per NETA-ATS 2013 Section 7.13; document location, measure resistance and record results. Investigate point-to-point resistance readings that exceed 0.5 ohms. Notify Project Owner of any issues identified and propose a corrective action plan to be implemented as needed.	1 X per year

APPENDIX I Pollinators

Cypress Creek Renewables, LLC Pollinator Vegetation Management Memo

Cypress Creek Renewables, LLC (“CCR”) approaches every local solar PV facility site as an opportunity to provide local renewable energy, as well as to maintain or improve upon the local ecosystem. From a vegetation perspective, our goal is to stabilize the soil to add strength and durability for the long-term success of the generation facility and health of the land. CCR understands the value of sustainable long-term management practices and will continue to develop solutions to enhance these techniques and promote healthy biodiversity within local ecosystems.

In many cases, there is a need to re-seed the portions of the property after construction. There is not a single solution that works for all climates throughout our national footprint, but rather we work to employ best practices and techniques that are most appropriate for each unique, local environment. Some of the factors that we evaluate when making these decisions are:

- Preventing runoff
- Native vegetation
- Pollination and other insect services
- Air quality concerns
- Invasive species resistance
- Viable wildflower areas
- Rate of fescue growth

One of the most important considerations for the vegetation plan is the maintenance requirements for the site, which will vary tremendously given the local terrain, soils and microclimates. Our landscape managers employ different strategies to minimize the use of herbicides. When herbicides are deemed necessary, an effort is made to only apply highly bio-degradable, EPA registered and approved, solutions that are nontoxic to pets and wildlife. The guidelines below, adopted from vetted expert pollinator habitat management companies, shall be complied with when operating and maintaining facilities where there is pollinator habitat.

Pollinator Habitat Overview

CCR, by way of an Operation and Maintenance Agreement executed by CCR’s subsidiary, Cypress Creek O&M, LLC (“Provider”), on the one hand, and Project Owner, on the other hand, will maintain vegetation (including debris removal/control and other associated landscaping), for all property within the fence line and all property immediately surrounding fencing (within reason), specifically ensuring vegetation does not encroach on solar panels. Frequency of vegetation management visits is determined by both regional and seasonal factors.

Establishing a native pollinator habitat will provide a long term, low maintenance, ecologically sound landscape that is adapted to the existing conditions of the site. The revegetation plan will typically utilize species that are native to the project area, ensuring long-term success. Due to the height constraints presented by the solar panels to avoid shading impacts on energy

production, custom seed mixes will be designed using species that are generally not taller than 2 feet. A separate, perimeter seed mix will be proposed for the areas outside of the array.

Typical Site Preparation Practices

1. The site will be fine graded whenever possible.
2. If perennial non- native vegetation and/or invasive species exists, EPA-approved herbicides are to be applied with a minimum of 10 days prior to pollinator habitat prep. These herbicides are similar to commonly utilized agricultural herbicides.
3. Seedbed prep will then take place using construction grade tilling and harrowing equipment. If soil amendments, such as lime and fertilizer, are necessary, they will be applied at rates deemed necessary after a soil test is completed.

Typical Seed & Seeding Practices

1. Native species are to be seeded, typically before August 10th or between September 20th and the first freeze.
2. A cover crop, such as oats, can be planted to provide soil erosion control and allow native seeds to germinate quickly.
3. Wildflower seed is applied via broadcasting.
4. Restricted areas, such as the array footprint, will have grass seed applied by a seed drill. In open area, broadcasting will be the method to apply grass seed.

Typical Vegetation Management Practices

Integrated Pest Management (IPM) involves spot treatment of certain herbicides by a crew on foot or with light duty trucks. IPM is a common technique deployed during the first 3 years of pollinator habitat establishment and on an as needed basis after the 3rd growing season. Other techniques include herbicide wicking, spot mowing, and hand pulling. The correct timing and herbicide choice is essential to ensure adequate control while at the same time minimizing collateral damage. The below table details a typical vegetation management plan for years 1-5.

Growing Season	Land Management
1	2-3 mowings
2	2-3 IPM trips, including 2-4 mowings
3	2-3 IPM trips, including 1-2 mowings
4	2 IPM trips
5	1 IPM trip

Table 1. An outline of typical timed management practices per the recommendations of Prairie Restorations. A growing season represents the year.

In general, a minimum of a 5-year contract between a vetted pollinator habitat management company and Provider is necessary for all monitoring efforts of pollinator habitat, due to the nature of native seed germination and growth. After the fifth year, annual visits by the habitat management company are advised to identify any additional habitat monitoring needs. The costs of all such visits shall be addressed by Provider.

- The first 2-3 years are the most intensive and crucial in terms of needed maintenance.
- Mowing is typically the predominant maintenance strategy during the first and second growing season. Typically, 2-4 mowings are needed depending on weather patterns.
- During the 3rd growing season and beyond, maintenance becomes more targeted control.
- Cover crops allow the native seeds to germinate quickly, while also providing erosion control. Erosion control blankets for native vegetation is typical if the site is sloped greater than 3:1.

Management Assumptions

- Atypical site-specific reseeding may be required during the maintenance period to maintain the desired vegetation.
- Herbicides will be used only when necessary to treat highly invasive, non-native species to ensure establishment of desired native plant communities.

Solar Site Constraints

Available spacing between solar array rows can affect which equipment is used. A low-growing shade tolerant species will be used in the array area, such as one already within the multi-species and diverse pollinator-friendly seed mix to be planted in the buffer area. The seed mixes, selected by Provider in consultation with the habitat management company, shall provide pollinator services, while also preventing soil erosion and storm water runoff. By covering the entire site in beneficial and meaningful species, the benefits of the habitat area can extend across the entire site and nearby agricultural land.

EXHIBIT G. SWPPP

STORMWATER POLLUTION PREVENTION PLAN

for

**Leatherleaf Solar, LLC
7501 Ivison Road
Town of Byron, New York**

Prepared For:

**Leatherleaf Solar, LLC
P.O. Box 173
Latham, NY 12110**

Prepared By:

**Langan Engineering, Environmental, Surveying
Landscape Architecture and Geology, D.P.C.
One North Broadway, Suite 910
White Plains, New York 10601**

February 24, 2023

LANGAN

Project No.: 190087901

Preparer of the SWPPP

I hereby certify that the Stormwater Pollution Prevention Plan (SWPPP) for this project has been prepared in accordance with the terms and conditions of the SPDES General Permit for Stormwater Discharges from Construction Activity. Furthermore, I understand that certifying false, incorrect or inaccurate information is a violation of this permit and the laws of the State of New York and could subject me to criminal, civil or administrative proceedings.

Name: Michael Finan, PE, LEED-AP

Date: February 24, 2023



Table of Contents

1	Executive Summary.....	1
2	Project Information	2
3	Site Conditions	3
3.1	Soils.....	3
3.2	Water Resources	4
3.3	Floodplains.....	4
3.4	Cultural Resources.....	4
4	Stormwater Management Plan.....	9
4.1	Stormwater Site Planning	9
4.1.1	Preservation of Natural Features and Conservation	9
4.1.2	Reduction of Impervious Cover	10
4.1.3	Runoff Reduction Techniques	10
4.1.4	Standard Stormwater Management Practices	11
4.2	Hydrologic Analysis.....	13
4.2.1	Drainage Patterns.....	13
4.2.2	Stormwater Modeling.....	13
4.2.3	Water Quality Control.....	14
4.2.4	Runoff Reduction Volume	14
4.2.5	Water Quantity Control.....	15
5	Erosion and Sediment Control Plan.....	15
5.1	Construction Sequencing Schedule and Phasing.....	15
5.2	Erosion and Sediment Control Measures.....	15
5.3	Pollution Prevention Controls.....	16
5.4	Soil Stabilization and Restoration	18
6	Stormwater Pollution Prevention Plan Implementation.....	19
6.1	Certification Statements	19
6.2	Pre-Construction Meeting	20
6.3	Construction Site Log	20
6.4	Construction Inspections and Maintenance	20
6.4.1	Contractor Maintenance Inspection Requirements.....	20
6.4.2	Qualified Inspector Inspection Requirements.....	20
7	Termination of Coverage.....	21
8	Post-Construction Requirements.....	21
8.1	Record Retention	21
8.2	Inspection and Maintenance	22

Table of Contents

9 Conclusion 22

Tables

Table 1-1: Overall Summary of Peak Discharge Rates..... 1
Table 2-1: Project Summary 2
Table 3-1: USDA Soil Data..... 3
Table 4-1: Preservation of Natural Features and Conservation 9
Table 4-2: Reduction of Impervious Cover..... 10
Table 4-3: Runoff-Reduction Practices 10
Table 4-4: Standard Stormwater Management Practices 12
Table 4-5: Rainfall Data..... 14
Table 4-6: Total Water Quality Volume 14
Table 4-7: Implemented Runoff Reduction Volume Techniques 14
Table 5-1: Soil Restoration 18

Figures

Figure 1: Site Location Map 5
Figure 2: Soils Map 6
Figure 3: Flood Insurance Rate Map..... 7
Figure 4: Cultural Resource Map..... 8
Figure 5: Pre-Development Watershed Map Appendix F
Figure 6: Post-Development Watershed Map Appendix G

Appendices

Appendix A: NYSDEC SPDES General Permit
Appendix B: NYSDEC SPDES General Permit Forms
Appendix C: Certification Statements
Appendix D: Example Inspection Form
Appendix E: Design Calculations
Appendix F: Pre-Development Stormwater Analysis
Appendix G: Post-Development Stormwater Analysis
Appendix H: Post-Construction Inspection & Maintenance
Appendix I: NYSDEC Permeable Haul Road Design

1 Executive Summary

This Stormwater Pollution Prevention Plan (SWPPP) and accompanying project plans have been prepared in accordance with the New York State Department of Environmental Conservation (NYSDEC) State Pollutant Discharge Elimination System (SPDES) General Permit for Stormwater Discharges from Construction Activity (General Permit) latest revision, the *New York State Stormwater Management Design Manual (Design Manual)* latest revision, and the *New York State Standards and Specifications for Erosion and Sediment Control* latest revision. The Applicant, Leatherleaf Solar, LLC, is proposing to develop a 179.89 acre property at 7501 Ivison Road, in the Town of Byron, New York. The project, Leatherleaf Solar, LLC, is a large-scale solar energy system that consists of solar racks, permeable driveway, perimeter fencing, and stormwater management practices. Access to the site is provided by a 20-foot wide permeable driveway (see [Appendix I](#)). The project will maintain existing drainage patterns as much as practicable.

The pre- and post-development conditions were analyzed using the USDA Soil Conservation Service Publication Technical Release (TR-55) "Urban Hydrology for Small Watersheds", which provides procedures for estimating runoff and peak discharges in small watersheds. The analysis is based upon the watershed areas, land coverage, soil group types, curve numbers (CN), times of concentration (Tc), rainfall distribution type, and rainfall amount for the design storm events. The pre- and post-development peak discharge rates of runoff have been evaluated utilizing stormwater modeling software. An overall comparison of the pre- and post-development peak discharge rates for each of the design storms analyzed is provided in the table below.

Table 1-1: Overall Summary of Peak Discharge Rates

Storm Event	Pre (cfs)	Post (cfs)	Diff (cfs)
1-year	3.49	3.49	0.00
10-year	29.18	29.18	0.00
100-year	103.89	103.89	0.00

The overall comparison of the pre- and post-development stormwater runoff peak discharge rates demonstrates no significant adverse impacts to the design points analyzed. In addition, the erosion control, sediment control, pollution-prevention, and stormwater management measures to be implemented during construction as outlined in this SWPPP and project drawings will minimize soil erosion and control sediment transport off site, and after construction will control the water quality and quantity of stormwater runoff.

2 Project Information

The Applicant is proposing to develop a property in the Town of Byron, NY (see [Figure 1](#)). Below is a summary of the project information:

Table 2-1: Project Summary

Project Name:	Leatherleaf Solar, LLC
Project Location:	7501 Ivison Road, Town of Byron, NY
Property Tax ID No.:	Section 9., Block 1, Lot 7.113
Property Acreage:	179.89 acres
Municipality:	Town of Byron, NY, which is not a municipal separate storm sewer system (MS4)
Project Description:	A large-scale solar energy system that consists of solar racks, permeable driveway, and associated electrical appurtenances
Estimated Disturbed Area:	34.96 acres, which does require coverage under the SPDES General Permit
Existing Site Conditions:	Woods (fair condition), meadow (fair condition), impervious area (gravel) 2.60 acres of existing impervious area
Proposed Site Conditions:	Woods (fair condition), meadow (good condition), impervious area (gravel, pavement) 2.71 acres of proposed impervious area (increase of 0.11 acres)
Stormwater Management Practices:	Filter strip
Construction Duration:	From September 2023 to September 2024 including planned winter shutdowns.

Coverage under the New York State Department of Environmental Conservation (NYSDEC) State Pollutant Discharge Elimination System (SPDES) General Permit for Stormwater Discharges from Construction Activity (General Permit) latest revision will be required (see [Appendix A](#)), since the project involves soil disturbance of 1 or more acres. The Notice of Intent (NOI) form will be submitted to the NYSDEC before construction begins to obtain coverage under the SPDES General Permit. The form has been provided in [Appendix B](#).

3 Site Conditions

3.1 Soils

The United States Department of Agriculture (USDA) Soil Conservation Service Soil Survey for Genesee County has been reviewed. The surficial soil conditions are shown in [Figure 2](#) and are summarized in the table below.

Table 3-1: USDA Soil Data

Map Symbol	Description	Depth to Groundwater (ft.)	Depth to Bedrock (ft.)	Hydrologic Soil Group
Ad	Alden mucky silt loam	0	> 6	C/D ¹
ApA	Appleton silt loam, 0 to 3 percent slopes	0.7	> 6	B/D ¹
GP	Gravel Pits	> 6	> 6	
HIA	Hilton loam, 0 to 3 percent slopes	1.8	> 6	B/D ¹
HIB	Hilton loam, 3 to 8 percent slopes	1.8	> 6	B/D ¹
LmA	Lima silt loam, 0 to 3 percent slopes	1.8	> 6	B/D ¹
OnA	Ontario loam, 0 to 3 percent slopes	> 6	> 6	B
OnB	Ontario loam, 3 to 8 percent slopes	> 6	> 6	B
PhB	Palmyra gravelly loam, 3 to 8 percent slopes	> 6	> 6	A
PhC	Palmyra gravelly loam, 8 to 15 percent slopes	> 6	> 6	A

¹ Soil types Ad, ApA, HIA, HIB, and LmA were analyzed as hydrologic soil group 'D' with poorly draining soils based on their proximity to the on site wetlands.

The Soil Conservation Service defines the hydrologic soil groups as follows:

- **Type A Soils:** Soils having a high infiltration rate and low runoff potential when thoroughly wet. These soils consist mainly of deep, well-drained to excessively drained sands or gravelly sands. These soils have a high rate of water transmission.
- **Type B Soils:** Soils having a moderate infiltration rate when thoroughly wet. These soils consist mainly of moderately deep to deep, moderately well to well-drained soils with moderately fine to moderately coarse textures. These soils have a moderate rate of water transmission.
- **Type C Soils:** Soils having a low infiltration rate when thoroughly wet. These soils consist mainly of soils with a layer that impedes downward movement of water, and soils with moderately fine to fine texture. These soils have a low rate of water transmission.

- **Type D Soils:** Soils having a very low infiltration rate and high runoff potential when thoroughly wet. These soils consist mainly of clays that have high shrink-swell potential, soils that have a permanent high water table, soils that have a clay pan or clay layer at or near the surface, and soils that are shallow over nearly impervious material. These soils have a very low rate of water transmission.

3.2 Water Resources

A wetland and waterbody delineation was conducted by GEI Consultants, Inc. in August 2022. Two wetlands were identified within the total property area and appear to be mapped by the NWI Mapper. The site also features one NWI mapped stream.

Aquifer mapping was reviewed to determine whether the site is over a sole source, primary or principal aquifer. According to the Environmental Protection Agency "Sole Source Aquifers" map, the site is not over a sole-source aquifer. According to the NYSDEC "Primary and Principal Aquifers in New York State" map, the site is not over a primary aquifer or a principal aquifer.

3.3 Floodplains

The site is not within a flood plain or special flood hazard area per FIA Flood Hazard Boundary Maps No. H08 dated December 6, 1974. This is the most current documentation offered by FEMA for the site (see [Figure 3](#)).

3.4 Cultural Resources

According to the New York State Office of Parks, Recreation and Historic Preservation (NYSOPRHP) Cultural Resource Information System (CRIS), the property is not within an archaeological sensitive area; not listed or eligible for listing on the state or national registers of historic places; and not adjacent to a place listed or eligible for listing on the state or national registers of historic places (see [Figure 4](#)).

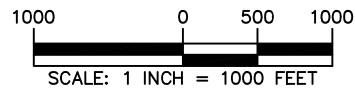
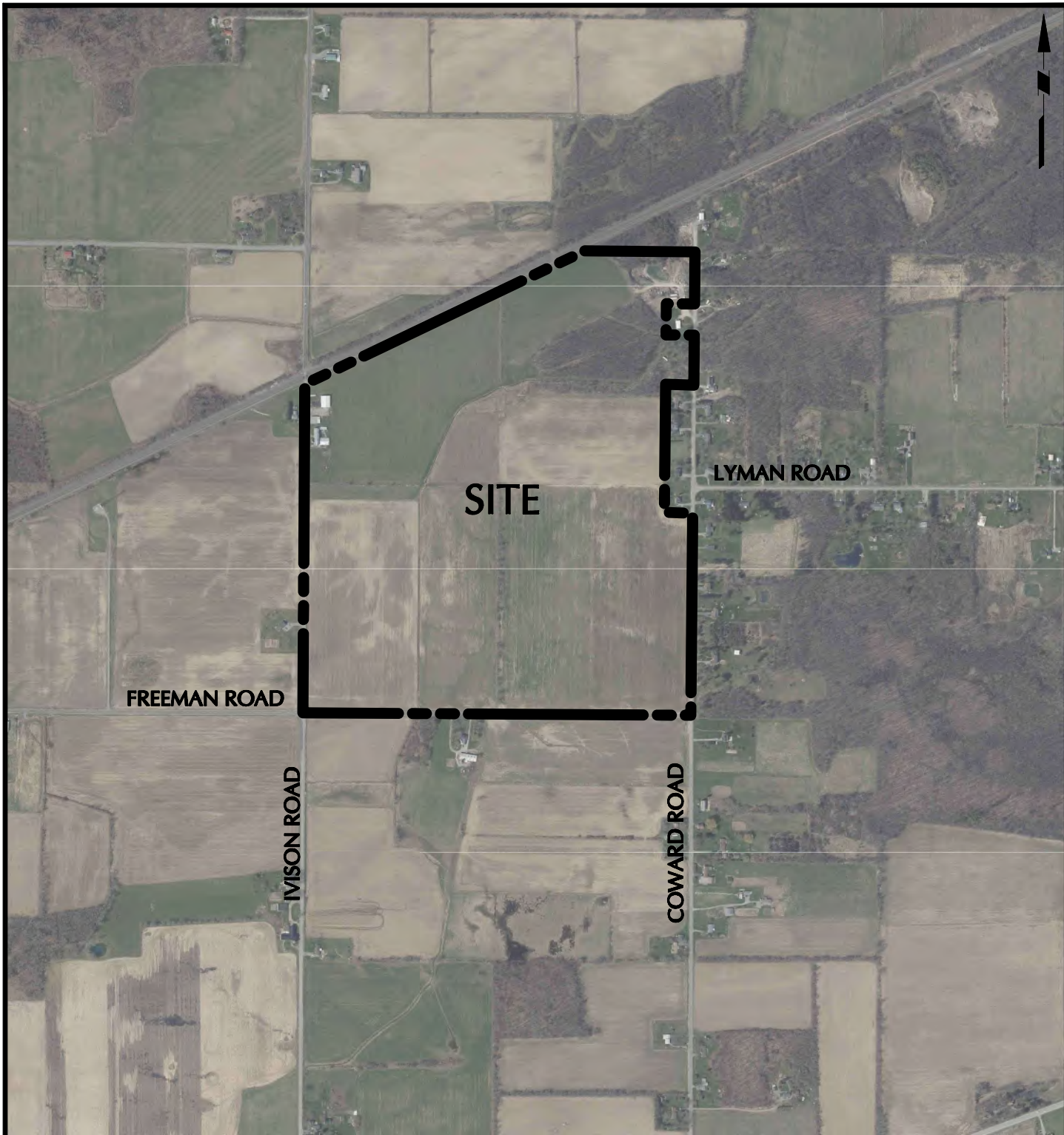

WARNING: IT IS A VIOLATION OF THE NYS EDUCATION LAW ARTICLE 145 FOR ANY PERSON, UNLESS HE OR SHE IS ACTING UNDER THE DIRECTION OF A LICENSED PROFESSIONAL ENGINEER, LAND SURVEYOR OR GEOLOGIST, TO ALTER THIS ITEM IN ANY WAY.

<p>LANGAN Langan Engineering, Environmental, Surveying, Landscape Architecture, and Geology, D.P.C. One North Broadway, Suite 910 White Plains, NY 10601 T: 914.323.7400 F: 914.323.7401 www.langan.com</p>	Project	Drawing Title	Project No.	Figure
	LEATHERLEAF SOLAR, LLC	SITE LOCATION MAP	190087901	FG01
	TAX ID: 9-1-7.113 TOWN OF BYRON		Date 02/24/2023	
	GENESEE COUNTY NEW YORK		Drawn By GN Checked By SS	Sheet 1 of 6

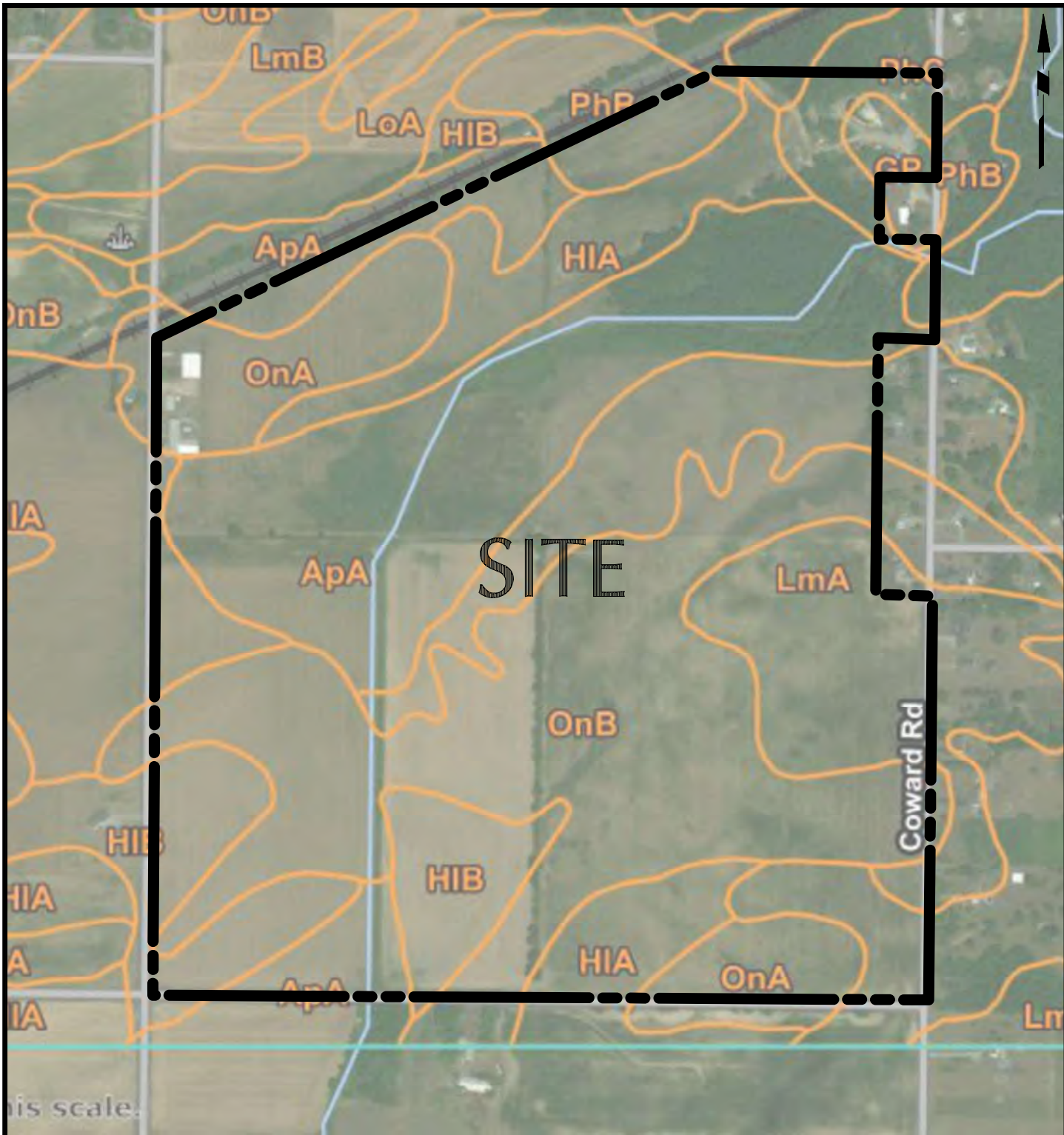

SITE

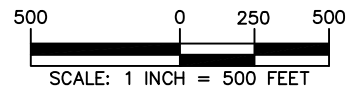

WARNING: IT IS A VIOLATION OF THE NYS EDUCATION LAW ARTICLE 145 FOR ANY PERSON, UNLESS HE OR SHE IS ACTING UNDER THE DIRECTION OF A LICENSED PROFESSIONAL ENGINEER, LAND SURVEYOR OR GEOLOGIST, TO ALTER THIS ITEM IN ANY WAY.

<p>LANGAN Langan Engineering, Environmental, Surveying, Landscape Architecture, and Geology, D.P.C. One North Broadway, Suite 910 White Plains, NY 10601 T: 914.323.7400 F: 914.323.7401 www.langan.com</p>	Project	Drawing Title	Project No.	Figure
	LEATHERLEAF SOLAR, LLC	SOILS MAP	190087901	FG02
	TAX ID: 9-1-7.113 TOWN OF BYRON		Date 02/24/2023	
	GENESEE COUNTY NEW YORK		Drawn By GN Checked By SS	Sheet 2 of 6

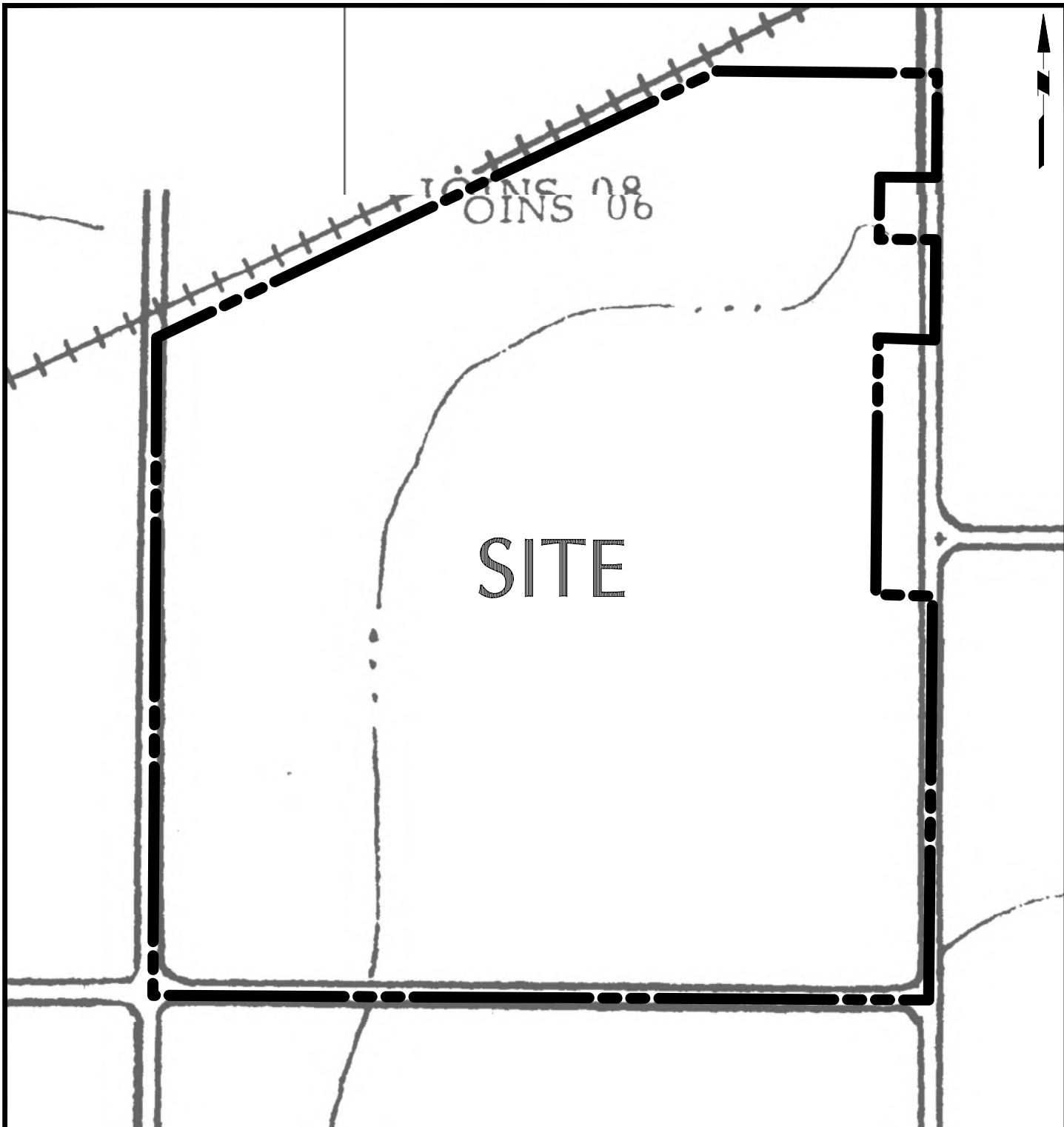

WARNING: IT IS A VIOLATION OF THE NYS EDUCATION LAW ARTICLE 145 FOR ANY PERSON, UNLESS HE OR SHE IS ACTING UNDER THE DIRECTION OF A LICENSED PROFESSIONAL ENGINEER, LAND SURVEYOR OR GEOLOGIST, TO ALTER THIS ITEM IN ANY WAY.



<p>LANGAN Langan Engineering, Environmental, Surveying, Landscape Architecture, and Geology, D.P.C. One North Broadway, Suite 910 White Plains, NY 10601 T: 914.323.7400 F: 914.323.7401 www.langan.com</p>	Project	Drawing Title	Project No.	Figure
	LEATHERLEAF SOLAR, LLC	FLOOD INSURANCE RATE MAP	190087901	FG03
	TAX ID: 9-1-7.113 TOWN OF BYRON		Date 02/24/2023	
	GENESEE COUNTY NEW YORK		Drawn By GN Checked By SS	Sheet 3 of 6

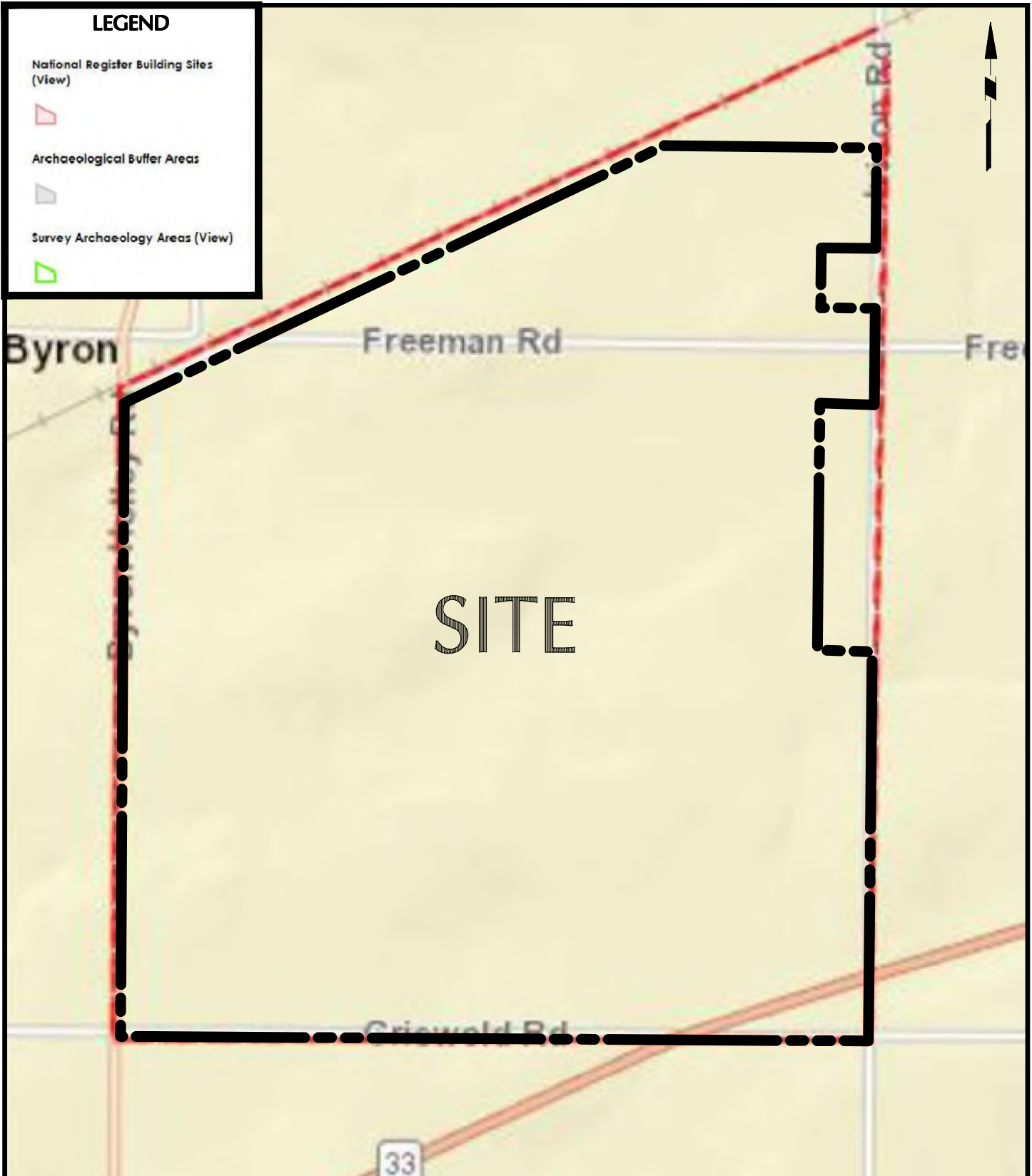

WARNING: IT IS A VIOLATION OF THE NYS EDUCATION LAW ARTICLE 145 FOR ANY PERSON, UNLESS HE OR SHE IS ACTING UNDER THE DIRECTION OF A LICENSED PROFESSIONAL ENGINEER, LAND SURVEYOR OR GEOLOGIST, TO ALTER THIS ITEM IN ANY WAY.

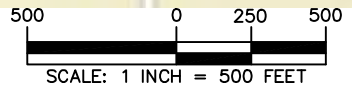

<p>LANGAN Langan Engineering, Environmental, Surveying, Landscape Architecture, and Geology, D.P.C. One North Broadway, Suite 910 White Plains, NY 10601 T: 914.323.7400 F: 914.323.7401 www.langan.com</p>	Project	Drawing Title	Project No.	Figure
	LEATHERLEAF SOLAR, LLC	CULTURAL RESOURCES MAP	190087901	FG04
	TAX ID: 9-1-7.113 TOWN OF BYRON		Date	
	GENESEE COUNTY NEW YORK		02/24/2023	
			Drawn By	
			GN	
			Checked By	
			SS	
				Sheet 4 of 6

4 Stormwater Management Plan

4.1 Stormwater Site Planning

4.1.1 Preservation of Natural Features and Conservation

Preservation of natural features includes techniques to identify and preserve natural areas that can be used to protect water, habitat and vegetative resources. Conservation includes designing elements of the development in a way that the site design takes advantage of a site’s natural features, preserves sensitive areas and identifies constraints and opportunities to prevent or reduce negative effects of a development. An evaluation of the preservation of natural features and conservation planning practices is provided in the table below.

Table 4-1: Preservation of Natural Features and Conservation

Practice	Description	Incorporated	Reason
Preservation of Undisturbed Areas	Delineate and place into permanent conservation undisturbed forests, native vegetated areas, riparian corridors, wetlands, and natural terrain.	Considered and Not Applied	There are areas of forested, native vegetated areas, wetlands, and wetland buffers that will remain undisturbed; however, they will not be placed into a permanent conservation.
Preservation of Buffers	Define, delineate and preserve naturally vegetated buffers along perennial streams, rivers, shorelines and wetlands.	Considered and Not Applied	There are areas of streams, wetlands, and wetland buffers that will remain undisturbed; however, they will not be placed into a permanent conservation.
Reduction of Clearing and Grading	Limit clearing and grading to the minimum amount needed for roads, driveways, foundations, utilities and stormwater management facilities.	Considered and Applied	None
Locating Development in Less Sensitive Areas	Avoid sensitive resource areas such as floodplains, steep slopes, erodible soils, wetlands, mature forests and critical habitats by locating development to fit the terrain in areas that will create the least impact.	Considered and Applied	None
Open Space Design	Use clustering, conservation design or open space design to reduce impervious cover, preserve more open space and protect water resources.	N/A	
Soil Restoration	Restore the original properties and porosity of the soil by deep till and amendment with compost to reduce the generation of runoff and enhance the runoff reduction performance of post construction practices.	Considered and Applied	None

4.1.2 Reduction of Impervious Cover

Reduction of impervious cover includes methods to reduce the amount of rooftops, parking lots, roadways, sidewalks, and other surfaces that do not allow rain to infiltrate into the soil. An evaluation of the reduction of impervious cover techniques is provided in the table below.

Table 4-2: Reduction of Impervious Cover

Practice	Description	Incorporated	Reason
Roadway Reduction	Minimize roadway widths and lengths to reduce site impervious area	N/A	
Sidewalk Reduction	Minimize sidewalk lengths and widths to reduce site impervious area	N/A	
Driveway Reduction	Minimize driveway lengths and widths to reduce site impervious area	Considered and Applied	The driveway width is the minimum width allowed for emergency service access
Cul-de-sac Reduction	Minimize the number of cul-de-sacs and incorporate landscaped areas to reduce their impervious cover.	N/A	
Building Footprint Reduction	Reduce the impervious footprint of residences and commercial buildings by using alternate or taller buildings while maintaining the same floor to area ratio.	N/A	
Parking Reduction	Reduce imperviousness on parking lots by eliminating unneeded spaces, providing compact car spaces and efficient parking lanes, minimizing stall dimensions, using porous pavement surfaces in overflow parking areas, and using multi-storied parking decks where appropriate.	N/A	

4.1.3 Runoff Reduction Techniques

Green infrastructure techniques use the natural features of the site and promote runoff reduction through micromanaging runoff, promoting groundwater recharge, increasing losses through evapotranspiration, and emulating the existing hydrology. An evaluation of the runoff reduction practices is provided in the table below.

Table 4-3: Runoff-Reduction Practices

Practice	Description	Incorporated	Reason
Conservation of Natural Areas	Retain the pre-development hydrologic and water quality characteristics of undisturbed natural areas, stream and wetland buffers by restoring and/or permanently conserving these areas on a site.	Considered and Not Applied	There are areas of forested, native vegetated areas, and wetlands that will remain undisturbed; however, they will not be placed into a permanent conservation.

Practice	Description	Incorporated	Reason
Sheet flow to Riparian Buffers or Filter Strips	Undisturbed natural areas such as forested conservation areas and stream buffers or vegetated filter strips and riparian buffers can be used to treat and control stormwater runoff from some areas of a development project.	Considered and Applied	None
Vegetated Open Swale	The natural drainage paths, or properly designed vegetated channels, can be used instead of constructing underground storm sewers or concrete open channels to increase time of concentration, reduce the peak discharge, and provide infiltration.	Considered and Not Applied	Vegetated swales are not proposed.
Tree Planting/Tree Box	Plant or conserve trees to reduce stormwater runoff, increase nutrient uptake, and provide bank stabilization. Trees can be used for applications such as landscaping, stormwater management practice areas, conservation areas and erosion and sediment control.	Considered and Not Applied	Trees cannot be planted in the fence perimeter of the solar facility, since it could cause shading of the racks.
Disconnection of Rooftop Runoff	Direct runoff from residential rooftop areas and upland overland runoff flow to designated pervious areas.	N/A	
Stream Daylighting for Redevelopment Projects	Stream daylight previously culverted/piped streams to restore natural habitats, better attenuate runoff by increasing the storage size and promoting infiltration.	N/A	
Rain Garden	Manage and treat small volumes of stormwater runoff using a conditioned planting soil bed and planting materials to filter runoff stored within a shallow depression.	Considered and Not Applied	A different runoff reduction practice will be used.
Green Roof	Capture runoff through a layer of vegetation and soil installed on top of a conventional flat or sloped roof.	N/A	
Stormwater Planter	Small landscaped stormwater treatment devices that can be designed as infiltration or filtering practices.	N/A	
Rain Tank/Cistern	Capture and store stormwater runoff to be used for irrigation systems or filtered and reused for non-contact activities.	N/A	
Porous Pavement	Pervious types of pavements that provide an alternative to conventional paved surfaces, designed to infiltrate rainfall through the surface.	Considered and Applied	The driveway is proposed to be constructed of large pervious stone.

4.1.4 Standard Stormwater Management Practices

Standard stormwater management practices (SMPs) are structural practices that are designed to capture and treat the water quality volume. Some of the standard SMPs can also provide runoff reduction or water quantity controls. An evaluation of the standard SMPs is provided in the table below.

Table 4-4: Standard Stormwater Management Practices

Practice	Description	Incorporated	Reason
Stormwater Ponds	Constructed stormwater retention basins that have a permanent pool (or micropool). Runoff from each rain event is detained and treated in the pool. Can be used to treat hostspot runoff if 2 feet minimum separation to seasonally groundwater is provided or if a permeable liner is provided.	Considered and Not Applied	This practice would take up a larger footprint than the proposed filter strips.
Stormwater Wetlands	Constructed stormwater wetlands that are structural practices that incorporate wetland plants to store and treat runoff. Can be used to treat hostspot runoff if 2 feet minimum separation to seasonally groundwater is provided.	Considered and Not Applied	This practice would take up a larger footprint than the proposed filter strips.
Stormwater Infiltration	Excavated trench or basin used to capture and allow for infiltration into the surrounding soils from the bottom and sides of the basin or trench. Also, a standard stormwater practice that also provides runoff reduction volume capacity.	Considered and Not Applied	This practice would take up a larger footprint than the proposed filter strips.
Underground Infiltration System	An underground perforated piping or chambers used to capture and allow for infiltration into the surrounding soils from the bottom and sides. Also, a standard stormwater practice that also provides runoff reduction volume capacity.	Considered and Not Applied	Proposed practice is above ground for easier access for maintenance.
Stormwater Filtering Systems – Sand or Organic	Aboveground or underground multi-chamber practice designed to treat stormwater runoff through filtration using a sediment forebay, primary filter media and underdrain. Can be used to treat hostspot runoff if a permeable liner is provided.	Considered and Not Applied	Proposed practice is above ground for easier access for maintenance.
Stormwater Filtering Systems – Bioretention	Shallow basin or landscaped area that uses engineered soils and vegetation to capture and treat runoff. Can be used to treat hostspot runoff if a permeable liner is provided. Also, a standard stormwater practice that also provides runoff reduction volume capacity.	Considered and Not Applied	This practice would take up a larger footprint than the proposed filter strips.
Stormwater Open Channel Systems - Dry Swale	Vegetated channel that captures and treats runoff within dry cells formed by check dams or other means. Can be used to treat hostspot runoff if a permeable liner is provided. Also, a standard stormwater practice that also provides runoff reduction volume capacity.	Considered and Not Applied	The site slopes do not meet the criteria to take credit for vegetated open swales.
Stormwater Open Channel Systems - Wet Swale	Vegetated channel that captures and treats runoff within wet cells formed by check dams or other means.	Considered and Not Applied	The site slopes do not meet the criteria to take credit for vegetated open swales.

4.2 Hydrologic Analysis

4.2.1 Drainage Patterns

The site is located within the Black Creek Watershed. Looking at the proposed lease portion of the property under existing conditions, stormwater runoff generally flows overland to the east and south portion of the property where it leaves the site from the delineated wetlands cutting through the property.

In the proposed conditions, stormwater runoff outside the development will continue to flow overland in the same direction as in the existing conditions. Stormwater runoff within the development will follow the existing drainage patterns as much as possible.

4.2.2 Stormwater Modeling

The USDA Soil Conservation Service Publication Technical Release (TR-55) "Urban Hydrology for Small Watersheds" has been used to analyze the pre- and post-development rainfall runoff rates and volumes. Watershed areas, curve numbers (CN), and times of concentration (T_c) were calculated for each contributing watershed. The curve number is a land-sensitive coefficient that dictates the relationship between total rainfall depth and direct storm runoff. Based on the land coverage and soil group types, the average CN has been determined for each subcatchment for both the existing and proposed conditions.

The T_c is defined as the time for runoff to travel from the hydraulically most distant point in the watershed to a Design Point (DP). Values of the time of concentration were determined for both the pervious and impervious area of each watershed for both the existing and proposed conditions based on land cover and slope of the flow path using methods outlined in TR-55. As per TR-55, the minimum T_c used in 0.1 hours (for 6 minutes).

An overall watershed boundary was developed for the pre- and post-development conditions (see [Figure 5](#) and [Figure 6](#), respectively). Runoff conditions were analyzed at the Design Point (DP) to compare the proposed development to the existing conditions. A description of the selected design point is provided below:

- Design Point 1: Wetlands, from the eastern property line eventually leading to the southern property line.

Rainfall data used in the modeling and analysis was obtained from the isohyet maps provided in the *New York State Stormwater Management Design Manual* and the Northeast Regional Climate Center (NRCC). A Type II rainfall distribution was used to evaluate the pre- and post-development stormwater runoff conditions for the 1-, 10-, and 100-year 24-hour storm events. The rainfall data used in the stormwater management design and analysis is provided in the table below.

Table 4-5: Rainfall Data

Storm Event	24-Hour Rainfall
90 th Percentile ^(1,2)	1.00 inches
1-year	1.57 inches
2-year ⁽³⁾	1.83 inches
10-year	2.65 inches
100-year	4.45 inches

1. The 90th percentile 24-hour rainfall value was taken from the *New York State Stormwater Management Design Manual*. The other 24-hour rainfall values are taken from NRCC.
2. The 90th percentile 24-hour rainfall amount was used to calculate the required total water quality volume.
3. The 2-year 24-hour rainfall amount was used to calculate the sheet flow component in the time of concentration.

The rainfall data used in the stormwater management design and analysis is provided in [Appendix E](#). The results of the computer modeling used to analyze the pre- and post-development watershed conditions are provided in [Appendix F](#) and [Appendix G](#), respectively.

4.2.3 Water Quality Control

The water quality volumes have been determined based on the methodology described in the Design Manual. The total water quality volume is provided in the table below.

Table 4-6: Total Water Quality Volume

Subcatchment	Area (ac)	Impervious Area (ac)	WQ _v (cf)
100A	0.03	0.006	25
100B	0.03	0.006	25
Total	0.06	0.01	50

Detailed design calculations have been provided in [Appendix E](#).

4.2.4 Runoff Reduction Volume

Runoff reduction is achieved by infiltration, groundwater recharge, reuse, recycle, evaporation and evapotranspiration of 100 percent of the post-development water quality volumes to replicate pre-development hydrology by maintaining pre-construction infiltration, peak runoff flow, discharge volume, and minimizing concentrated flow by using runoff-control techniques to provide treatment in a distributed manner before runoff reaches the collection system. The runoff-reduction-volume techniques that were used to reduce the total required water quality volume are in the table below.

Table 4-7: Implemented Runoff Reduction Volume Techniques

Techniques/ Practices	RRv Reduction Method	Reduction Amount
Filter Strips	Area Reduction	100% of the WQv

After applying the above runoff-reduction techniques, the total required water quality volume was reduced 100 percent. Detailed design calculations have been provided in [Appendix E](#).

4.2.5 Water Quantity Control

This project was designed to minimize any changes to the hydrology that would result in an increase in the discharge rate. Since 100% of the runoff reduction has been reduced, the channel protection volume requirement is being waived.

A comparison of the pre- and post-development peak discharge rates is provided in the table below.

Table 4-8: Summary of Peak Discharge Rates

Storm Event	Design Point	Pre (cfs)	Post (cfs)	Diff (cfs)
1-year	1	3.49	3.49	0.00
10-year	1	29.18	29.18	0.00
100-year	1	103.89	103.89	0.00

Comparison of the peak discharge rates for pre- and post-development watershed conditions demonstrates that the peak rate of runoff from the proposed development will not be increased. The pre- and post-development stormwater models have been provided in [Appendix F](#) and [Appendix G](#), respectively.

5 Erosion and Sediment Control Plan

5.1 Construction Sequencing Schedule and Phasing

The project will be completed in 7 phases. The general construction sequencing is shown on the project plans. In addition, the Applicant is not requesting to disturb more than 5 acres of soil at any one time.

5.2 Erosion and Sediment Control Measures

Temporary erosion and sediment control measures to be used during construction generally include the following:

- **Stabilized Construction Access** - Before construction, the stabilized construction access shall be installed to reduce the tracking of sediment onto adjacent roadways. Construction traffic must enter and exit the site at the stabilized construction access. The stabilized construction access shall be maintained in good condition to control tracking of sediment onto rights-of-way or streets. When necessary, the placement of additional aggregate atop the filter fabric shall be done to maintain the minimum thickness. Sediments and soils spilled, dropped, or washed onto the public rights-of-way shall be removed immediately.
- **Dust Control** - Water trucks or other approved water source shall be used, as needed, during construction to reduce dust generated on the site. Dust control shall be provided by the general contractor to a degree acceptable to the owner/operator, and in compliance with the applicable local and state dust control requirements.

- **Temporary Soil Stockpile** - Materials, such as topsoil, shall be temporarily stockpiled (if necessary) on site during construction. Stockpiles shall be located away from storm drainage, water bodies or courses, and shall be properly protected from erosion in accordance with the NYSDEC standard detail.
- **Silt Fencing** - Before initiation of and during construction, silt fencing shall be established along the perimeter of areas to be disturbed as a result of the construction up gradient of water courses or adjacent properties. These barriers may extend into non-impact areas to adequately protect adjacent lands. Clearing and grubbing shall be performed only as necessary for the installation of the sediment control barrier. To maximize effectiveness of the silt fencing, daily inspections shall be performed by site personnel. Maintenance of the fence shall be performed as needed and when directed by the Qualified Inspector.
- **Temporary Seeding** - Within seven days after construction ceases on any particular area of the site, all disturbed areas where there shall be no construction for longer than 14 days shall be temporarily seeded and mulched to minimize erosion and sediment loss. Other stabilization methods maybe approved by the Qualified Inspector.
- **Fiber Rolls** – Fiber rolls shall be installed on the finished slopes 3:1 or steeper to reduce sheet flow on slopes help minimize erosion while final seeding and planting is underway.
- **Dewatering** - Dewatering, if required, must not be discharged directly into wetlands, water courses, water bodies, and storm sewer systems without appropriate protection or authorizations. Proper methods and devices shall be used to the extent permitted by law, such as pumping water into temporary sediment basins, providing surge protection at the inlet and outlet of pumps, floating the intake of the pump, or other methods to minimize and retain the suspended solids.

Permanent erosion and sediment control measures to be used after construction generally include the following:

- **Establish Permanent Vegetation** - Disturbed areas not covered by impervious surfaces shall be seeded in accordance with the accompanying plans. The type of seed, mulch, and maintenance measures shall be followed. All areas at final grade shall be seeded and mulched within 14 days after completion of the major construction. All seeded areas shall be protected with mulch or hay. Final site stabilization is achieved when soil-disturbing activities have been completed and a uniform, perennial vegetative cover with a density of 80 percent has been established or equivalent stabilization measures (such as the use of mulches or geotextiles) have been employed on the disturbed unpaved areas and areas not covered by permanent structures.

Specific erosion and sediment control measures, inspection frequency, and remediation procedures are provided in the subsequent sections and on the accompanying project plans.

5.3 Pollution Prevention Controls

Good housekeeping practices are designed to maintain a clean and orderly work environment. Good housekeeping measures shall be maintained throughout the construction process by those parties involved with the direct care and development of the site. The following measures shall

be implemented to control the possible exposure of harmful substances and materials to stormwater runoff:

1. Material resulting from the clearing and grubbing operation shall be stockpiled away from storm drainage, water bodies or watercourses and surrounded with adequate erosion and sediment control measures. Soil stockpile locations shall be exposed no longer than 14 days before seeding.
2. Equipment maintenance areas shall be protected from stormwater flows and shall be supplied with appropriate waste receptacles for spent chemicals, solvents, oils, greases, gasoline, and any pollutants that might contaminate the surrounding habitat or water supply. Equipment wash-down zones shall be within areas draining to sediment control devices.
3. The use of detergents for large-scale (e.g., vehicles, buildings, pavement surfaces) washing is prohibited.
4. Material storage locations and facilities (e.g., covered storage areas, storage sheds) shall be on-site and shall be stored according to the manufacturer's standards in a dedicated staging area. Chemicals, paints, solvents, fertilizers, and other toxic material shall be stored in waterproof containers. Runoff containing such materials shall be collected, removed from the site, treated and disposed of at an approved solid waste or chemical disposal facility.
5. Hazardous spills shall be immediately contained to prevent pollutants from entering the surrounding habitat or water supply. Spill Kits shall be provided on site and shall be displayed in a prominent location for ease of access and use. Spills greater than 5 gallons shall be reported to the NYSDEC Response Unit at 1-800-457-7362. In addition, a record of the incidents or notifications shall be documented and attached to the SWPPP.
6. Portable sanitary waste facilities shall be provided on site for workers and shall be properly maintained.
7. Dumpsters or debris containers shall be on site and shall be of adequate size to manage respective materials. Regular collection and disposal of wastes must occur as required.
8. Temporary concrete washout facilities shall be a minimum of 50 feet from storm drain inlets, open drainage facilities, and watercourses. Each facility should be away from construction traffic or access areas to prevent disturbance or tracking. A sign shall be installed adjacent to each washout facility to inform concrete equipment operators to use the proper facilities. When temporary concrete washout facilities are no longer required for the work, the hardened concrete shall be removed and disposed of. Materials used to construct the temporary concrete washout facilities shall be removed and disposed of. Holes, depressions or other ground disturbance caused by the removal of the temporary concrete washout facilities shall be backfilled or repaired, seeded, and mulched for final stabilization. Wastewater discharges from washout of concrete is prohibited.
9. Non-stormwater components of site discharge shall be clean water. Water used for construction, which discharges from the site, must originate from a public water supply

or approved private well. Water used for construction that does not originate from an approved public supply must not discharge from the site.

10. Discharges from dewatering activities, including discharges from dewatering trenches and excavations, shall be managed by appropriate control measures.
11. Wastewater discharges from washout and cleanout of stucco, paint, form-release oils, curing compounds, and other construction materials is prohibited.

5.4 Soil Stabilization and Restoration

Stabilization

In areas where soil disturbance has temporarily or permanently ceased, the application of soil stabilization measures shall be initiated by the end of the next business day and completed within 14 days from the date the current soil disturbance ceased. The soil-stabilization measures shall be in conformance with the *New York State Standards and Specifications for Erosion and Sediment Control*, latest edition.

Restoration

Soil restoration shall be performed in the disturbed areas. The soils shall be restored in accordance with the table below.

Table 5-1: Soil Restoration

Type of Soil Disturbance	Soil Restoration Requirement	
No Soil Disturbance (e.g., preservation of natural features)	Restoration not required.	
Minimal Soil Disturbance (e.g., clearing and grubbing)	Restoration not required.	
Areas where top soil is stripped only (e.g., no change in grade)	Apply 6 inches of topsoil in Type A and B soils	Aerate and apply 6 inches of topsoil in Type C and D soils
Areas of cut or fill	Aerate and apply 6 inches of topsoil in Type A and B soils	Apply full soil restoration in Type C and D soils
Heavy traffic areas on site (especially in 5 to 25 feet around buildings, but not within a 5-foot perimeter around foundation walls)	Apply full soil restoration (see below).	
Areas where runoff reduction or infiltration practices are applied	Restoration not required, but can be applied to enhance soil infiltration.	

Full Soil Restoration

Before applying full soil restoration, all construction, including construction equipment and material storage, site cleanup and trafficking, should be finished and the site closed to further disturbance. Full soil restoration should be performed with a heavy-duty agricultural-grade deep ripper, deep angled-leg subsoiler, or equivalent machinery to achieve de-compaction.

Full soil restoration is implemented in a two-phase process:

1. Deep rip the affected thickness of exposed subsoil, aggressively fracturing it before the protected topsoil is reapplied on the site.
2. De-compact simultaneously through the restored topsoil layer and upper half of the affected subsoil.

Low to Moderate Subsoil Moisture

The disturbed soils are returned to rough grade and the following is applied:

1. Apply 3 inches of compost over the subsoil.
2. Till compost a minimum of 12 inches into the subsoil using a cat-mounted ripper, tractor-mounted disc, or tiller mixing and circulating air and compost into subsoils.
3. Rock-pick until uplifted stone and rock of 4 inches or larger size are cleaned off the site. All construction material and foreign debris and existing root masses shall be removed from proposed planting areas.
4. Apply 6 inches of topsoil. Newly installed planting soils shall be mixed with existing soils where they meet in order to create a transitional gradient to allow for proper drainage.
5. Install plants and vegetation in accordance with the Landscaping Plan.

6 Stormwater Pollution Prevention Plan Implementation

6.1 Certification Statements

Before starting construction, the owner/operator, contractors, and subcontractors are required to sign the certification statements provided in [Appendix C](#).

The owner/operator must sign a copy of the Owner's/Operator's certification before submitting the Notice of Intent. The owner/operator acknowledges that the SWPPP has been developed and will be implemented as the first element of construction and agrees to comply with the terms and conditions of the general permit for which the Notice of Intent is being submitted.

The owner/operator must identify the contractors and subcontractors that will be responsible for installing, constructing, repairing, replacing, inspecting, and maintaining the erosion and sediment control practices; and constructing the post-construction stormwater management practices included in the SWPPP. The contractors and subcontractors must identify at least one trained individual from their company who will be responsible for implementation of the SWPPP. This person will be known as the trained contractor. At least one trained contractor will be on site daily when soil disturbing activities are being performed. If new or additional contractors are hired to implement measures identified in the SWPPP after construction has begun, they must also sign the certification statement and identify their responsibilities.

6.2 Pre-Construction Meeting

Before beginning construction, the owner/operator must set up a pre-construction meeting with the town representative, qualified professional, qualified inspector, contractors, and subcontractors. The primary purpose of the pre-construction meeting is to discuss the responsibilities of each party as they relate to the implementation of the SWPPP and to clarify any questions.

6.3 Construction Site Log

The owner/operator must maintain a copy of the following, including but not limited to: General Permit, signed NOI, signed MS4 Acceptance form, NOI Acknowledgement Letter, SWPPP, signed certification statements, and inspections reports. The documents must be maintained in a secure location onsite. The secure location must be accessible during normal business hours to an individual performing a compliance inspection.

6.4 Construction Inspections and Maintenance

6.4.1 Contractor Maintenance Inspection Requirements

The trained contractor must inspect the erosion and sediment control practices and pollution-prevention measures to verify that they are being maintained in effective operating condition. The inspections will be conducted as follows:

- For construction sites where soil disturbance is on-going, the trained contractor must inspect the measures within the active work area daily. If deficiencies are identified, the contractor will begin implementing corrective actions within one business day and must complete the corrective actions by the end of the day.
- For construction sites where soil disturbance activities have been temporarily suspended (e.g., winter shutdown) and temporary stabilization measures have been applied to all disturbed areas, the trained contractor can stop conducting the maintenance inspections. The trained contractor must conduct the daily maintenance inspections as soil disturbance resumes.
- For construction sites where soil disturbance has been shut down with partial project completion, the trained contractor can stop conducting the maintenance inspections if all areas disturbed as of the project shutdown date have achieved final stabilization and all post-construction stormwater management practices required for the completed part of the project have been constructed in conformance with the SWPPP and are operational.

6.4.2 Qualified Inspector Inspection Requirements

The owner/operator must have a Qualified Inspector conduct site inspections to verify the stability and effectiveness of protective measures and practices employed during construction. The site inspections will be conducted as follows:

- For construction sites where soil disturbance is ongoing, the Qualified Inspector must conduct a site inspection at least once every seven days.
- For construction sites where soil disturbance activities have been temporarily suspended (e.g., winter shutdown) and temporary stabilization measures have been applied to all disturbed areas, the Qualified Inspector must conduct a site inspection at least once every 30 days. The owner/operator must notify the NYSDEC or MS4 in writing before reducing the frequency of the inspections.
- For construction sites where soil disturbance activities have been shut down with partial project completion, the Qualified Inspector can stop conducting inspections if all areas disturbed as of the project shutdown date have achieved final stabilization and all post-construction stormwater management practices are operational. The owner/operator must notify the NYSDEC or the MS4 in writing before the shutdown.

All erosion and sediment control inspections shall be performed in accordance with this SWPPP, accompanying project plans, latest revision of *New York State Standards and Specifications for Erosion and Sediment Control*, and procedures outlined in Appendix H of the latest revision of the *New York State Stormwater Management Design Manual*. Inspection reports must identify and document the maintenance of the erosion and sediment control measures. An Example inspection report has been provided in [Appendix D](#).

Specific maintenance components, schedule frequency, inspection parameters and remediation procedures are provided on the accompanying project plans. Any adjustments or modifications to the maintenance plan shall be noted in the inspection reports and submitted to the town for approval.

7 Termination of Coverage

The owner/operator may terminate coverage when:

- a. Total project completion has occurred.
- b. A planned shutdown with partial project completion has occurred.
- c. Property ownership changes or when there is a change in operational control over the construction plans and specifications; and the new owner/operator has obtained coverage under the SPDES General Permit.
- d. Coverage under an alternative SPDES general permit or an individual SPDES permit has been obtained.

The completed NOT must be submitted to the NYSDEC to cancel coverage. A blank copy of the NOT has been provided in [Appendix B](#).

8 Post-Construction Requirements

8.1 Record Retention

Following construction, the owner/operator must retain a copy of the signed NOI, NOI Acknowledgement Letter, SWPPP, project plans, and any inspection reports that were prepared

in conjunction with the General Permit for at least five years from the date that the NYSDEC receives a complete NOT.

8.2 Inspection and Maintenance

Post-construction inspections and maintenance will be performed by Leatherleaf Solar, LLC. Inspections and maintenance for the various site components and stormwater management facilities shall be performed in accordance with the accompanying project plans and this SWPPP. Detailed post-construction inspections and maintenance procedures are provided in [Appendix H](#).

9 Conclusion

This Stormwater Pollution Prevention Plan has been developed in accordance with the requirements of the Town of Byron and the New York State Department of Environmental Conservation (NYSDEC) State Pollutant Discharge Elimination System (SPDES) Phase II technical guidelines. This SWPPP identifies the erosion control, sediment control, pollution-prevention, and stormwater management measures to be implemented during construction to minimize soil erosion and control sediment transport off site, and after construction to control and treat stormwater runoff from the developed site.

In the opinion of the SWPPP preparer, the proposed project will not have adverse impacts if the measures for erosion control, sediment control, pollution prevention, and stormwater management measures are properly constructed and maintained in accordance with the requirements outlined herein and on the accompanying project plans.

\\langan.com\data\WPW\data\9\190087901\Project Data\Discipline\Site Civil\Reports\2023-02-24 SWPPP\2023-02-24 Full SWPPP Leatherleaf Solar.docx

Leatherleaf Solar, LLC
7501 Ivison Road
Town of Byron, New York

Appendix A: NYSDEC SPDES General Permit



Department of
Environmental
Conservation

NEW YORK STATE
DEPARTMENT OF ENVIRONMENTAL CONSERVATION

SPDES GENERAL PERMIT
FOR STORMWATER DISCHARGES

From

CONSTRUCTION ACTIVITY

Permit No. GP- 0-20-001

Issued Pursuant to Article 17, Titles 7, 8 and Article 70
of the Environmental Conservation Law

Effective Date: January 29, 2020

Expiration Date: January 28, 2025

John J. Ferguson

Chief Permit Administrator



Authorized Signature

1-23-20
Date

Address: NYS DEC
Division of Environmental Permits
625 Broadway, 4th Floor
Albany, N.Y. 12233-1750

PREFACE

Pursuant to Section 402 of the Clean Water Act (“CWA”), stormwater *discharges* from certain *construction activities* are unlawful unless they are authorized by a *National Pollutant Discharge Elimination System (“NPDES”)* permit or by a state permit program. New York administers the approved State Pollutant Discharge Elimination System (SPDES) program with permits issued in accordance with the New York State Environmental Conservation Law (ECL) Article 17, Titles 7, 8 and Article 70.

An *owner or operator* of a *construction activity* that is eligible for coverage under this permit must obtain coverage prior to the *commencement of construction activity*. Activities that fit the definition of “*construction activity*”, as defined under 40 CFR 122.26(b)(14)(x), (15)(i), and (15)(ii), constitute construction of a *point source* and therefore, pursuant to ECL section 17-0505 and 17-0701, the *owner or operator* must have coverage under a SPDES permit prior to *commencing construction activity*. The *owner or operator* cannot wait until there is an actual *discharge* from the *construction site* to obtain permit coverage.

***Note: The italicized words/phrases within this permit are defined in Appendix A.**

**NEW YORK STATE DEPARTMENT OF ENVIRONMENTAL CONSERVATION
SPDES GENERAL PERMIT FOR STORMWATER DISCHARGES FROM
CONSTRUCTION ACTIVITIES**

Table of Contents

Part 1. PERMIT COVERAGE AND LIMITATIONS	1
A. Permit Application	1
B. Effluent Limitations Applicable to Discharges from Construction Activities	1
C. Post-construction Stormwater Management Practice Requirements	4
D. Maintaining Water Quality	8
E. Eligibility Under This General Permit.....	9
F. Activities Which Are Ineligible for Coverage Under This General Permit	9
Part II. PERMIT COVERAGE	12
A. How to Obtain Coverage	12
B. Notice of Intent (NOI) Submittal	13
C. Permit Authorization	13
D. General Requirements For Owners or Operators With Permit Coverage	15
E. Permit Coverage for Discharges Authorized Under GP-0-15-002.....	17
F. Change of Owner or Operator	17
Part III. STORMWATER POLLUTION PREVENTION PLAN (SWPPP).....	18
A. General SWPPP Requirements	18
B. Required SWPPP Contents	20
C. Required SWPPP Components by Project Type.....	24
Part IV. INSPECTION AND MAINTENANCE REQUIREMENTS	24
A. General Construction Site Inspection and Maintenance Requirements	24
B. Contractor Maintenance Inspection Requirements	24
C. Qualified Inspector Inspection Requirements	25
Part V. TERMINATION OF PERMIT COVERAGE	29
A. Termination of Permit Coverage	29
Part VI. REPORTING AND RETENTION RECORDS	31
A. Record Retention	31
B. Addresses	31
Part VII. STANDARD PERMIT CONDITIONS.....	31
A. Duty to Comply.....	31
B. Continuation of the Expired General Permit.....	32
C. Enforcement.....	32
D. Need to Halt or Reduce Activity Not a Defense.....	32
E. Duty to Mitigate	33
F. Duty to Provide Information.....	33
G. Other Information	33
H. Signatory Requirements.....	33
I. Property Rights	35
J. Severability.....	35

K.	Requirement to Obtain Coverage Under an Alternative Permit.....	35
L.	Proper Operation and Maintenance	36
M.	Inspection and Entry	36
N.	Permit Actions	37
O.	Definitions	37
P.	Re-Opener Clause	37
Q.	Penalties for Falsification of Forms and Reports.....	37
R.	Other Permits.....	38
APPENDIX A – Acronyms and Definitions		39
	Acronyms.....	39
	Definitions.....	40
APPENDIX B – Required SWPPP Components by Project Type		48
	Table 1.....	48
	Table 2.....	50
APPENDIX C – Watersheds Requiring Enhanced Phosphorus Removal		52
APPENDIX D – Watersheds with Lower Disturbance Threshold		58
APPENDIX E – 303(d) Segments Impaired by Construction Related Pollutant(s)		59
APPENDIX F – List of NYS DEC Regional Offices		65

Part 1. PERMIT COVERAGE AND LIMITATIONS

A. Permit Application

This permit authorizes stormwater *discharges* to *surface waters of the State* from the following *construction activities* identified within 40 CFR Parts 122.26(b)(14)(x), 122.26(b)(15)(i) and 122.26(b)(15)(ii), provided all of the eligibility provisions of this permit are met:

1. *Construction activities* involving soil disturbances of one (1) or more acres; including disturbances of less than one acre that are part of a *larger common plan of development or sale* that will ultimately disturb one or more acres of land; excluding *routine maintenance activity* that is performed to maintain the original line and grade, hydraulic capacity or original purpose of a facility;
2. *Construction activities* involving soil disturbances of less than one (1) acre where the Department has determined that a *SPDES* permit is required for stormwater *discharges* based on the potential for contribution to a violation of a *water quality standard* or for significant contribution of *pollutants* to *surface waters of the State*.
3. *Construction activities* located in the watershed(s) identified in Appendix D that involve soil disturbances between five thousand (5,000) square feet and one (1) acre of land.

B. Effluent Limitations Applicable to Discharges from Construction Activities

Discharges authorized by this permit must achieve, at a minimum, the effluent limitations in Part I.B.1. (a) – (f) of this permit. These limitations represent the degree of effluent reduction attainable by the application of best practicable technology currently available.

1. Erosion and Sediment Control Requirements - The *owner or operator* must select, design, install, implement and maintain control measures to *minimize* the *discharge of pollutants* and prevent a violation of the *water quality standards*. The selection, design, installation, implementation, and maintenance of these control measures must meet the non-numeric effluent limitations in Part I.B.1.(a) – (f) of this permit and be in accordance with the New York State Standards and Specifications for Erosion and Sediment Control, dated November 2016, using sound engineering judgment. Where control measures are not designed in conformance with the design criteria included in the technical standard, the *owner or operator* must include in the *Stormwater Pollution Prevention Plan* (“SWPPP”) the reason(s) for the

deviation or alternative design and provide information which demonstrates that the deviation or alternative design is *equivalent* to the technical standard.

- a. **Erosion and Sediment Controls.** Design, install and maintain effective erosion and sediment controls to *minimize* the *discharge* of *pollutants* and prevent a violation of the *water quality standards*. At a minimum, such controls must be designed, installed and maintained to:
- (i) *Minimize* soil erosion through application of runoff control and soil stabilization control measure to *minimize pollutant discharges*;
 - (ii) Control stormwater *discharges*, including both peak flowrates and total stormwater volume, to *minimize* channel and *streambank* erosion and scour in the immediate vicinity of the *discharge* points;
 - (iii) *Minimize* the amount of soil exposed during *construction activity*;
 - (iv) *Minimize* the disturbance of *steep slopes*;
 - (v) *Minimize* sediment *discharges* from the site;
 - (vi) Provide and maintain *natural buffers* around surface waters, direct stormwater to vegetated areas and maximize stormwater infiltration to reduce *pollutant discharges*, unless *infeasible*;
 - (vii) *Minimize* soil compaction. Minimizing soil compaction is not required where the intended function of a specific area of the site dictates that it be compacted;
 - (viii) Unless *infeasible*, preserve a sufficient amount of topsoil to complete soil restoration and establish a uniform, dense vegetative cover; and
 - (ix) *Minimize* dust. On areas of exposed soil, *minimize* dust through the appropriate application of water or other dust suppression techniques to control the generation of pollutants that could be discharged from the site.
- b. **Soil Stabilization.** In areas where soil disturbance activity has temporarily or permanently ceased, the application of soil stabilization measures must be initiated by the end of the next business day and completed within fourteen (14) days from the date the current soil disturbance activity ceased. For construction sites that *directly discharge* to one of the 303(d) segments

listed in Appendix E or is located in one of the watersheds listed in Appendix C, the application of soil stabilization measures must be initiated by the end of the next business day and completed within seven (7) days from the date the current soil disturbance activity ceased. See Appendix A for definition of *Temporarily Ceased*.

- c. **Dewatering.** *Discharges* from *dewatering* activities, including *discharges* from *dewatering* of trenches and excavations, must be managed by appropriate control measures.

- d. **Pollution Prevention Measures.** Design, install, implement, and maintain effective pollution prevention measures to *minimize* the *discharge* of *pollutants* and prevent a violation of the *water quality standards*. At a minimum, such measures must be designed, installed, implemented and maintained to:
 - (i) *Minimize* the *discharge* of *pollutants* from equipment and vehicle washing, wheel wash water, and other wash waters. This applies to washing operations that use clean water only. Soaps, detergents and solvents cannot be used;

 - (ii) *Minimize* the exposure of building materials, building products, construction wastes, trash, landscape materials, fertilizers, pesticides, herbicides, detergents, sanitary waste, hazardous and toxic waste, and other materials present on the site to precipitation and to stormwater. Minimization of exposure is not required in cases where the exposure to precipitation and to stormwater will not result in a *discharge* of *pollutants*, or where exposure of a specific material or product poses little risk of stormwater contamination (such as final products and materials intended for outdoor use) ; and

 - (iii) Prevent the *discharge* of *pollutants* from spills and leaks and implement chemical spill and leak prevention and response procedures.

- e. **Prohibited *Discharges*.** The following *discharges* are prohibited:
 - (i) Wastewater from washout of concrete;

 - (ii) Wastewater from washout and cleanout of stucco, paint, form release oils, curing compounds and other construction materials;

- (iii) Fuels, oils, or other *pollutants* used in vehicle and equipment operation and maintenance;
 - (iv) Soaps or solvents used in vehicle and equipment washing; and
 - (v) Toxic or hazardous substances from a spill or other release.
- f. Surface Outlets. When discharging from basins and impoundments, the outlets shall be designed, constructed and maintained in such a manner that sediment does not leave the basin or impoundment and that erosion at or below the outlet does not occur.

C. Post-construction Stormwater Management Practice Requirements

1. The *owner or operator* of a *construction activity* that requires post-construction stormwater management practices pursuant to Part III.C. of this permit must select, design, install, and maintain the practices to meet the *performance criteria* in the New York State Stormwater Management Design Manual (“Design Manual”), dated January 2015, using sound engineering judgment. Where post-construction stormwater management practices (“SMPs”) are not designed in conformance with the *performance criteria* in the Design Manual, the *owner or operator* must include in the SWPPP the reason(s) for the deviation or alternative design and provide information which demonstrates that the deviation or alternative design is *equivalent* to the technical standard.
2. The *owner or operator* of a *construction activity* that requires post-construction stormwater management practices pursuant to Part III.C. of this permit must design the practices to meet the applicable *sizing criteria* in Part I.C.2.a., b., c. or d. of this permit.

a. Sizing Criteria for New Development

- (i) Runoff Reduction Volume (“RRv”): Reduce the total Water Quality Volume (“WQv”) by application of RR techniques and standard SMPs with RRv capacity. The total WQv shall be calculated in accordance with the criteria in Section 4.2 of the Design Manual.
- (ii) Minimum RRv and Treatment of Remaining Total WQv: Construction activities that cannot meet the criteria in Part I.C.2.a.(i) of this permit due to site limitations shall direct runoff from all newly constructed impervious areas to a RR technique or standard SMP with RRv capacity unless infeasible. The specific site limitations that prevent the reduction of 100% of the WQv shall be documented in the SWPPP.

For each impervious area that is not directed to a RR technique or standard SMP with RRv capacity, the SWPPP must include documentation which demonstrates that all options were considered and for each option explains why it is considered infeasible.

In no case shall the runoff reduction achieved from the newly constructed impervious areas be less than the Minimum RRv as calculated using the criteria in Section 4.3 of the Design Manual.

The remaining portion of the total WQv that cannot be reduced shall be treated by application of standard SMPs.

- (iii) Channel Protection Volume (“Cpv”): Provide 24 hour extended detention of the post-developed 1-year, 24-hour storm event; remaining after runoff reduction. The Cpv requirement does not apply when:
 - (1) Reduction of the entire Cpv is achieved by application of runoff reduction techniques or infiltration systems, or
 - (2) The site discharges directly to tidal waters, or fifth order or larger streams.

- (iv) *Overbank* Flood Control Criteria (“Qp”): Requires storage to attenuate the post-development 10-year, 24-hour peak discharge rate (Qp) to predevelopment rates. The Qp requirement does not apply when:
 - (1) the site discharges directly to tidal waters or fifth order or larger streams, or
 - (2) A downstream analysis reveals that *overbank* control is not required.

- (v) Extreme Flood Control Criteria (“Qf”): Requires storage to attenuate the post-development 100-year, 24-hour peak discharge rate (Qf) to predevelopment rates. The Qf requirement does not apply when:
 - (1) the site discharges directly to tidal waters or fifth order or larger streams, or
 - (2) A downstream analysis reveals that *overbank* control is not required.

b. Sizing Criteria for New Development in Enhanced Phosphorus Removal Watershed

- (i) Runoff Reduction Volume (RRv): Reduce the total Water Quality Volume (WQv) by application of RR techniques and standard SMPs with RRv capacity. The total WQv is the runoff volume from the 1-year, 24 hour design storm over the post-developed watershed and shall be

calculated in accordance with the criteria in Section 10.3 of the Design Manual.

- (ii) Minimum RRv and Treatment of Remaining Total WQv: *Construction activities* that cannot meet the criteria in Part I.C.2.b.(i) of this permit due to *site limitations* shall direct runoff from all newly constructed *impervious areas* to a RR technique or standard SMP with RRv capacity unless *infeasible*. The specific *site limitations* that prevent the reduction of 100% of the WQv shall be documented in the SWPPP. For each *impervious area* that is not directed to a RR technique or standard SMP with RRv capacity, the SWPPP must include documentation which demonstrates that all options were considered and for each option explains why it is considered *infeasible*.

In no case shall the runoff reduction achieved from the newly constructed *impervious areas* be less than the Minimum RRv as calculated using the criteria in Section 10.3 of the Design Manual. The remaining portion of the total WQv that cannot be reduced shall be treated by application of standard SMPs.

- (iii) Channel Protection Volume (Cpv): Provide 24 hour extended detention of the post-developed 1-year, 24-hour storm event; remaining after runoff reduction. The Cpv requirement does not apply when:
 - (1) Reduction of the entire Cpv is achieved by application of runoff reduction techniques or infiltration systems, or
 - (2) The site *discharges* directly to tidal waters, or fifth order or larger streams.
- (iv) *Overbank* Flood Control Criteria (Qp): Requires storage to attenuate the post-development 10-year, 24-hour peak *discharge* rate (Qp) to predevelopment rates. The Qp requirement does not apply when:
 - (1) the site *discharges* directly to tidal waters or fifth order or larger streams, or
 - (2) A downstream analysis reveals that *overbank* control is not required.
- (v) Extreme Flood Control Criteria (Qf): Requires storage to attenuate the post-development 100-year, 24-hour peak *discharge* rate (Qf) to predevelopment rates. The Qf requirement does not apply when:
 - (1) the site *discharges* directly to tidal waters or fifth order or larger streams, or
 - (2) A downstream analysis reveals that *overbank* control is not required.

c. Sizing Criteria for Redevelopment Activity

- (i) Water Quality Volume (WQv): The WQv treatment objective for *redevelopment activity* shall be addressed by one of the following options. *Redevelopment activities* located in an Enhanced Phosphorus Removal Watershed (see Part III.B.3. and Appendix C of this permit) shall calculate the WQv in accordance with Section 10.3 of the Design Manual. All other *redevelopment activities* shall calculate the WQv in accordance with Section 4.2 of the Design Manual.
- (1) Reduce the existing *impervious cover* by a minimum of 25% of the total disturbed, *impervious area*. The Soil Restoration criteria in Section 5.1.6 of the Design Manual must be applied to all newly created pervious areas, or
 - (2) Capture and treat a minimum of 25% of the WQv from the disturbed, *impervious area* by the application of standard SMPs; or reduce 25% of the WQv from the disturbed, *impervious area* by the application of RR techniques or standard SMPs with RRv capacity., or
 - (3) Capture and treat a minimum of 75% of the WQv from the disturbed, *impervious area* as well as any additional runoff from tributary areas by application of the alternative practices discussed in Sections 9.3 and 9.4 of the Design Manual., or
 - (4) Application of a combination of 1, 2 and 3 above that provide a weighted average of at least two of the above methods. Application of this method shall be in accordance with the criteria in Section 9.2.1(B) (IV) of the Design Manual.

If there is an existing post-construction stormwater management practice located on the site that captures and treats runoff from the *impervious area* that is being disturbed, the WQv treatment option selected must, at a minimum, provide treatment equal to the treatment that was being provided by the existing practice(s) if that treatment is greater than the treatment required by options 1 – 4 above.

- (ii) Channel Protection Volume (Cpv): Not required if there are no changes to hydrology that increase the *discharge* rate from the project site.
- (iii) *Overbank* Flood Control Criteria (Qp): Not required if there are no changes to hydrology that increase the *discharge* rate from the project site.
- (iv) Extreme Flood Control Criteria (Qf): Not required if there are no changes to hydrology that increase the *discharge* rate from the project site

d. Sizing Criteria for Combination of Redevelopment Activity and New Development

Construction projects that include both New Development and Redevelopment Activity shall provide post-construction stormwater management controls that meet the sizing criteria calculated as an aggregate of the Sizing Criteria in Part I.C.2.a. or b. of this permit for the New Development portion of the project and Part I.C.2.c of this permit for Redevelopment Activity portion of the project.

D. Maintaining Water Quality

The Department expects that compliance with the conditions of this permit will control *discharges* necessary to meet applicable *water quality standards*. It shall be a violation of the *ECL* for any discharge to either cause or contribute to a violation of *water quality standards* as contained in Parts 700 through 705 of Title 6 of the Official Compilation of Codes, Rules and Regulations of the State of New York, such as:

1. There shall be no increase in turbidity that will cause a substantial visible contrast to natural conditions;
2. There shall be no increase in suspended, colloidal or settleable solids that will cause deposition or impair the waters for their best usages; and
3. There shall be no residue from oil and floating substances, nor visible oil film, nor globules of grease.

If there is evidence indicating that the stormwater *discharges* authorized by this permit are causing, have the reasonable potential to cause, or are contributing to a violation of the *water quality standards*; the *owner or operator* must take appropriate corrective action in accordance with Part IV.C.5. of this general permit and document in accordance with Part IV.C.4. of this general permit. To address the *water quality standard* violation the *owner or operator* may need to provide additional information, include and implement appropriate controls in the SWPPP to correct the problem, or obtain an individual SPDES permit.

If there is evidence indicating that despite compliance with the terms and conditions of this general permit it is demonstrated that the stormwater *discharges* authorized by this permit are causing or contributing to a violation of *water quality standards*, or if the Department determines that a modification of the permit is necessary to prevent a violation of *water quality standards*, the authorized *discharges* will no longer be eligible for coverage under this permit. The Department may require the *owner or operator* to obtain an individual SPDES permit to continue discharging.

E. Eligibility Under This General Permit

1. This permit may authorize all *discharges* of stormwater from *construction activity to surface waters of the State* and *groundwaters* except for ineligible *discharges* identified under subparagraph F. of this Part.
2. Except for non-stormwater *discharges* explicitly listed in the next paragraph, this permit only authorizes stormwater *discharges*; including stormwater runoff, snowmelt runoff, and surface runoff and drainage, from *construction activities*.
3. Notwithstanding paragraphs E.1 and E.2 above, the following non-stormwater discharges are authorized by this permit: those listed in 6 NYCRR 750-1.2(a)(29)(vi), with the following exception: “Discharges from firefighting activities are authorized only when the firefighting activities are emergencies/unplanned”; waters to which other components have not been added that are used to control dust in accordance with the SWPPP; and uncontaminated *discharges* from *construction site* de-watering operations. All non-stormwater discharges must be identified in the SWPPP. Under all circumstances, the *owner or operator* must still comply with *water quality standards* in Part I.D of this permit.
4. The *owner or operator* must maintain permit eligibility to *discharge* under this permit. Any *discharges* that are not compliant with the eligibility conditions of this permit are not authorized by the permit and the *owner or operator* must either apply for a separate permit to cover those ineligible *discharges* or take steps necessary to make the *discharge* eligible for coverage.

F. Activities Which Are Ineligible for Coverage Under This General Permit

All of the following are **not** authorized by this permit:

1. *Discharges after construction activities* have been completed and the site has undergone *final stabilization*;
2. *Discharges* that are mixed with sources of non-stormwater other than those expressly authorized under subsection E.3. of this Part and identified in the SWPPP required by this permit;
3. *Discharges* that are required to obtain an individual SPDES permit or another SPDES general permit pursuant to Part VII.K. of this permit;
4. *Construction activities or discharges from construction activities* that may adversely affect an *endangered or threatened species* unless the *owner or*

operator has obtained a permit issued pursuant to 6 NYCRR Part 182 for the project or the Department has issued a letter of non-jurisdiction for the project. All documentation necessary to demonstrate eligibility shall be maintained on site in accordance with Part II.D.2 of this permit;

5. *Discharges* which either cause or contribute to a violation of *water quality standards* adopted pursuant to the *ECL* and its accompanying regulations;
6. *Construction activities* for residential, commercial and institutional projects:
 - a. Where the *discharges* from the *construction activities* are tributary to waters of the state classified as AA or AA-s; and
 - b. Which are undertaken on land with no existing *impervious cover*; and
 - c. Which disturb one (1) or more acres of land designated on the current United States Department of Agriculture (“USDA”) Soil Survey as Soil Slope Phase “D”, (provided the map unit name is inclusive of slopes greater than 25%), or Soil Slope Phase “E” or “F” (regardless of the map unit name), or a combination of the three designations.
7. *Construction activities* for linear transportation projects and linear utility projects:
 - a. Where the *discharges* from the *construction activities* are tributary to waters of the state classified as AA or AA-s; and
 - b. Which are undertaken on land with no existing *impervious cover*; and
 - c. Which disturb two (2) or more acres of land designated on the current USDA Soil Survey as Soil Slope Phase “D” (provided the map unit name is inclusive of slopes greater than 25%), or Soil Slope Phase “E” or “F” (regardless of the map unit name), or a combination of the three designations.

8. *Construction activities* that have the potential to affect an *historic property*, unless there is documentation that such impacts have been resolved. The following documentation necessary to demonstrate eligibility with this requirement shall be maintained on site in accordance with Part II.D.2 of this permit and made available to the Department in accordance with Part VII.F of this permit:
- a. Documentation that the *construction activity* is not within an archeologically sensitive area indicated on the sensitivity map, and that the *construction activity* is not located on or immediately adjacent to a property listed or determined to be eligible for listing on the National or State Registers of Historic Places, and that there is no new permanent building on the *construction site* within the following distances from a building, structure, or object that is more than 50 years old, or if there is such a new permanent building on the *construction site* within those parameters that NYS Office of Parks, Recreation and Historic Preservation (OPRHP), a Historic Preservation Commission of a Certified Local Government, or a qualified preservation professional has determined that the building, structure, or object more than 50 years old is not historically/archeologically significant.
 - 1-5 acres of disturbance - 20 feet
 - 5-20 acres of disturbance - 50 feet
 - 20+ acres of disturbance - 100 feet, or
 - b. DEC consultation form sent to OPRHP, and copied to the NYS DEC Agency Historic Preservation Officer (APO), and
 - (i) the State Environmental Quality Review (SEQR) Environmental Assessment Form (EAF) with a negative declaration or the Findings Statement, with documentation of OPRHP's agreement with the resolution; or
 - (ii) documentation from OPRHP that the *construction activity* will result in No Impact; or
 - (iii) documentation from OPRHP providing a determination of No Adverse Impact; or
 - (iv) a Letter of Resolution signed by the owner/operator, OPRHP and the DEC APO which allows for this *construction activity* to be eligible for coverage under the general permit in terms of the State Historic Preservation Act (SHPA); or
 - c. Documentation of satisfactory compliance with Section 106 of the National Historic Preservation Act for a coterminous project area:

- (i) No Affect
- (ii) No Adverse Affect
- (iii) Executed Memorandum of Agreement, or

d. Documentation that:

- (i) SHPA Section 14.09 has been completed by NYS DEC or another state agency.

9. *Discharges from construction activities* that are subject to an existing SPDES individual or general permit where a SPDES permit for *construction activity* has been terminated or denied; or where the *owner or operator* has failed to renew an expired individual permit.

Part II. PERMIT COVERAGE

A. How to Obtain Coverage

1. An *owner or operator* of a *construction activity* that is not subject to the requirements of a regulated, traditional land use control MS4 must first prepare a SWPPP in accordance with all applicable requirements of this permit and then submit a completed Notice of Intent (NOI) to the Department to be authorized to discharge under this permit.
2. An *owner or operator* of a *construction activity* that is subject to the requirements of a *regulated, traditional land use control MS4* must first prepare a SWPPP in accordance with all applicable requirements of this permit and then have the SWPPP reviewed and accepted by the *regulated, traditional land use control MS4* prior to submitting the NOI to the Department. The *owner or operator* shall have the “MS4 SWPPP Acceptance” form signed in accordance with Part VII.H., and then submit that form along with a completed NOI to the Department.
3. The requirement for an *owner or operator* to have its SWPPP reviewed and accepted by the *regulated, traditional land use control MS4* prior to submitting the NOI to the Department does not apply to an *owner or operator* that is obtaining permit coverage in accordance with the requirements in Part II.F. (Change of Owner or Operator) or where the *owner or operator* of the *construction activity* is the *regulated, traditional land use control MS4* . This exemption does not apply to *construction activities* subject to the New York City Administrative Code.

B. Notice of Intent (NOI) Submittal

1. Prior to December 21, 2020, an owner or operator shall use either the electronic (eNOI) or paper version of the NOI that the Department prepared. Both versions of the NOI are located on the Department's website (<http://www.dec.ny.gov/>). The paper version of the NOI shall be signed in accordance with Part VII.H. of this permit and submitted to the following address:

**NOTICE OF INTENT
NYS DEC, Bureau of Water Permits
625 Broadway, 4th Floor
Albany, New York 12233-3505**

2. Beginning December 21, 2020 and in accordance with EPA's 2015 NPDES Electronic Reporting Rule (40 CFR Part 127), the *owner or operator* must submit the NOI electronically using the *Department's* online NOI.
3. The *owner or operator* shall have the SWPPP preparer sign the "SWPPP Preparer Certification" statement on the NOI prior to submitting the form to the Department.
4. As of the date the NOI is submitted to the Department, the *owner or operator* shall make the NOI and SWPPP available for review and copying in accordance with the requirements in Part VII.F. of this permit.

C. Permit Authorization

1. An *owner or operator* shall not *commence construction activity* until their authorization to *discharge* under this permit goes into effect.
2. Authorization to *discharge* under this permit will be effective when the *owner or operator* has satisfied all of the following criteria:
 - a. project review pursuant to the State Environmental Quality Review Act ("SEQRA") have been satisfied, when SEQRA is applicable. See the Department's website (<http://www.dec.ny.gov/>) for more information,
 - b. where required, all necessary Department permits subject to the *Uniform Procedures Act* ("UPA") (see 6 NYCRR Part 621), or the equivalent from another New York State agency, have been obtained, unless otherwise notified by the Department pursuant to 6 NYCRR 621.3(a)(4). *Owners or operators of construction activities* that are required to obtain *UPA* permits

must submit a preliminary SWPPP to the appropriate DEC Permit Administrator at the Regional Office listed in Appendix F at the time all other necessary *UPA* permit applications are submitted. The preliminary SWPPP must include sufficient information to demonstrate that the *construction activity* qualifies for authorization under this permit,

- c. the final SWPPP has been prepared, and
 - d. a complete NOI has been submitted to the Department in accordance with the requirements of this permit.
3. An *owner or operator* that has satisfied the requirements of Part II.C.2 above will be authorized to *discharge* stormwater from their *construction activity* in accordance with the following schedule:
- a. For *construction activities* that are not subject to the requirements of a *regulated, traditional land use control MS4*:
 - (i) Five (5) business days from the date the Department receives a complete electronic version of the NOI (eNOI) for *construction activities* with a SWPPP that has been prepared in conformance with the design criteria in the technical standard referenced in Part III.B.1 and the *performance criteria* in the technical standard referenced in Parts III.B., 2 or 3, for *construction activities* that require post-construction stormwater management practices pursuant to Part III.C.; or
 - (ii) Sixty (60) business days from the date the Department receives a complete NOI (electronic or paper version) for *construction activities* with a SWPPP that has not been prepared in conformance with the design criteria in technical standard referenced in Part III.B.1. or, for *construction activities* that require post-construction stormwater management practices pursuant to Part III.C., the *performance criteria* in the technical standard referenced in Parts III.B., 2 or 3, or;
 - (iii) Ten (10) business days from the date the Department receives a complete paper version of the NOI for *construction activities* with a SWPPP that has been prepared in conformance with the design criteria in the technical standard referenced in Part III.B.1 and the *performance criteria* in the technical standard referenced in Parts III.B., 2 or 3, for *construction activities* that require post-construction stormwater management practices pursuant to Part III.C.

- b. For *construction activities* that are subject to the requirements of a *regulated, traditional land use control MS4*:
 - (i) Five (5) business days from the date the Department receives both a complete electronic version of the NOI (eNOI) and signed “MS4 SWPPP Acceptance” form, or
 - (ii) Ten (10) business days from the date the Department receives both a complete paper version of the NOI and signed “MS4 SWPPP Acceptance” form.
4. Coverage under this permit authorizes stormwater *discharges* from only those areas of disturbance that are identified in the NOI. If an *owner or operator* wishes to have stormwater *discharges* from future or additional areas of disturbance authorized, they must submit a new NOI that addresses that phase of the development, unless otherwise notified by the Department. The *owner or operator* shall not *commence construction activity* on the future or additional areas until their authorization to *discharge* under this permit goes into effect in accordance with Part II.C. of this permit.

D. General Requirements For Owners or Operators With Permit Coverage

1. The *owner or operator* shall ensure that the provisions of the SWPPP are implemented from the *commencement of construction activity* until all areas of disturbance have achieved *final stabilization* and the Notice of Termination (“NOT”) has been submitted to the Department in accordance with Part V. of this permit. This includes any changes made to the SWPPP pursuant to Part III.A.4. of this permit.
2. The *owner or operator* shall maintain a copy of the General Permit (GP-0-20-001), NOI, *NOI Acknowledgment Letter*, SWPPP, MS4 SWPPP Acceptance form, inspection reports, responsible contractor’s or subcontractor’s certification statement (see Part III.A.6.), and all documentation necessary to demonstrate eligibility with this permit at the *construction site* until all disturbed areas have achieved *final stabilization* and the NOT has been submitted to the Department. The documents must be maintained in a secure location, such as a job trailer, on-site construction office, or mailbox with lock. The secure location must be accessible during normal business hours to an individual performing a compliance inspection.
3. The *owner or operator* of a *construction activity* shall not disturb greater than five (5) acres of soil at any one time without prior written authorization from the Department or, in areas under the jurisdiction of a *regulated, traditional land*

use control MS4, the regulated, traditional land use control MS4 (provided the *regulated, traditional land use control MS4* is not the *owner or operator* of the *construction activity*). At a minimum, the *owner or operator* must comply with the following requirements in order to be authorized to disturb greater than five (5) acres of soil at any one time:

- a. The *owner or operator* shall have a *qualified inspector* conduct **at least two** (2) site inspections in accordance with Part IV.C. of this permit every seven (7) calendar days, for as long as greater than five (5) acres of soil remain disturbed. The two (2) inspections shall be separated by a minimum of two (2) full calendar days.
 - b. In areas where soil disturbance activity has temporarily or permanently ceased, the application of soil stabilization measures must be initiated by the end of the next business day and completed within seven (7) days from the date the current soil disturbance activity ceased. The soil stabilization measures selected shall be in conformance with the technical standard, New York State Standards and Specifications for Erosion and Sediment Control, dated November 2016.
 - c. The *owner or operator* shall prepare a phasing plan that defines maximum disturbed area per phase and shows required cuts and fills.
 - d. The *owner or operator* shall install any additional site-specific practices needed to protect water quality.
 - e. The *owner or operator* shall include the requirements above in their SWPPP.
4. In accordance with statute, regulations, and the terms and conditions of this permit, the Department may suspend or revoke an *owner's or operator's* coverage under this permit at any time if the Department determines that the SWPPP does not meet the permit requirements or consistent with Part VII.K..
 5. Upon a finding of significant non-compliance with the practices described in the SWPPP or violation of this permit, the Department may order an immediate stop to all activity at the site until the non-compliance is remedied. The stop work order shall be in writing, describe the non-compliance in detail, and be sent to the *owner or operator*.
 6. For *construction activities* that are subject to the requirements of a *regulated, traditional land use control MS4*, the *owner or operator* shall notify the

regulated, traditional land use control MS4 in writing of any planned amendments or modifications to the post-construction stormwater management practice component of the SWPPP required by Part III.A. 4. and 5. of this permit. Unless otherwise notified by the *regulated, traditional land use control MS4*, the *owner or operator* shall have the SWPPP amendments or modifications reviewed and accepted by the *regulated, traditional land use control MS4* prior to commencing construction of the post-construction stormwater management practice.

E. Permit Coverage for Discharges Authorized Under GP-0-15-002

1. Upon renewal of SPDES General Permit for Stormwater Discharges from *Construction Activity* (Permit No. GP-0-15-002), an *owner or operator* of a *construction activity* with coverage under GP-0-15-002, as of the effective date of GP- 0-20-001, shall be authorized to *discharge* in accordance with GP- 0-20-001, unless otherwise notified by the Department.

An *owner or operator* may continue to implement the technical/design components of the post-construction stormwater management controls provided that such design was done in conformance with the technical standards in place at the time of initial project authorization. However, they must comply with the other, non-design provisions of GP-0-20-001.

F. Change of Owner or Operator

1. When property ownership changes or when there is a change in operational control over the construction plans and specifications, the original *owner or operator* must notify the new *owner or operator*, in writing, of the requirement to obtain permit coverage by submitting a NOI with the Department. For *construction activities* subject to the requirements of a *regulated, traditional land use control MS4*, the original *owner or operator* must also notify the MS4, in writing, of the change in ownership at least 30 calendar days prior to the change in ownership.
2. Once the new *owner or operator* obtains permit coverage, the original *owner or operator* shall then submit a completed NOT with the name and permit identification number of the new *owner or operator* to the Department at the address in Part II.B.1. of this permit. If the original *owner or operator* maintains ownership of a portion of the *construction activity* and will disturb soil, they must maintain their coverage under the permit.
3. Permit coverage for the new *owner or operator* will be effective as of the date the Department receives a complete NOI, provided the original *owner or*

operator was not subject to a sixty (60) business day authorization period that has not expired as of the date the Department receives the NOI from the new *owner or operator*.

Part III. STORMWATER POLLUTION PREVENTION PLAN (SWPPP)

A. General SWPPP Requirements

1. A SWPPP shall be prepared and implemented by the *owner or operator* of each *construction activity* covered by this permit. The SWPPP must document the selection, design, installation, implementation and maintenance of the control measures and practices that will be used to meet the effluent limitations in Part I.B. of this permit and where applicable, the post-construction stormwater management practice requirements in Part I.C. of this permit. The SWPPP shall be prepared prior to the submittal of the NOI. The NOI shall be submitted to the Department prior to the *commencement of construction activity*. A copy of the completed, final NOI shall be included in the SWPPP.
2. The SWPPP shall describe the erosion and sediment control practices and where required, post-construction stormwater management practices that will be used and/or constructed to reduce the *pollutants* in stormwater *discharges* and to assure compliance with the terms and conditions of this permit. In addition, the SWPPP shall identify potential sources of pollution which may reasonably be expected to affect the quality of stormwater *discharges*.
3. All SWPPPs that require the post-construction stormwater management practice component shall be prepared by a *qualified professional* that is knowledgeable in the principles and practices of stormwater management and treatment.
4. The *owner or operator* must keep the SWPPP current so that it at all times accurately documents the erosion and sediment controls practices that are being used or will be used during construction, and all post-construction stormwater management practices that will be constructed on the site. At a minimum, the *owner or operator* shall amend the SWPPP, including construction drawings:
 - a. whenever the current provisions prove to be ineffective in minimizing *pollutants* in stormwater *discharges* from the site;

- b. whenever there is a change in design, construction, or operation at the *construction site* that has or could have an effect on the *discharge* of *pollutants*;
 - c. to address issues or deficiencies identified during an inspection by the *qualified inspector*, the Department or other regulatory authority; and
 - d. to document the final construction conditions.
5. The Department may notify the *owner or operator* at any time that the SWPPP does not meet one or more of the minimum requirements of this permit. The notification shall be in writing and identify the provisions of the SWPPP that require modification. Within fourteen (14) calendar days of such notification, or as otherwise indicated by the Department, the *owner or operator* shall make the required changes to the SWPPP and submit written notification to the Department that the changes have been made. If the *owner or operator* does not respond to the Department's comments in the specified time frame, the Department may suspend the *owner's or operator's* coverage under this permit or require the *owner or operator* to obtain coverage under an individual SPDES permit in accordance with Part II.D.4. of this permit.
6. Prior to the *commencement of construction activity*, the *owner or operator* must identify the contractor(s) and subcontractor(s) that will be responsible for installing, constructing, repairing, replacing, inspecting and maintaining the erosion and sediment control practices included in the SWPPP; and the contractor(s) and subcontractor(s) that will be responsible for constructing the post-construction stormwater management practices included in the SWPPP. The *owner or operator* shall have each of the contractors and subcontractors identify at least one person from their company that will be responsible for implementation of the SWPPP. This person shall be known as the *trained contractor*. The *owner or operator* shall ensure that at least one *trained contractor* is on site on a daily basis when soil disturbance activities are being performed.

The *owner or operator* shall have each of the contractors and subcontractors identified above sign a copy of the following certification statement below before they commence any *construction activity*:

"I hereby certify under penalty of law that I understand and agree to comply with the terms and conditions of the SWPPP and agree to implement any corrective actions identified by the *qualified inspector* during a site inspection. I also understand that the *owner or operator* must comply with

the terms and conditions of the most current version of the New York State Pollutant Discharge Elimination System ("SPDES") general permit for stormwater *discharges* from *construction activities* and that it is unlawful for any person to cause or contribute to a violation of *water quality standards*. Furthermore, I am aware that there are significant penalties for submitting false information, that I do not believe to be true, including the possibility of fine and imprisonment for knowing violations"

In addition to providing the certification statement above, the certification page must also identify the specific elements of the SWPPP that each contractor and subcontractor will be responsible for and include the name and title of the person providing the signature; the name and title of the *trained contractor* responsible for SWPPP implementation; the name, address and telephone number of the contracting firm; the address (or other identifying description) of the site; and the date the certification statement is signed. The *owner or operator* shall attach the certification statement(s) to the copy of the SWPPP that is maintained at the *construction site*. If new or additional contractors are hired to implement measures identified in the SWPPP after construction has commenced, they must also sign the certification statement and provide the information listed above.

7. For projects where the Department requests a copy of the SWPPP or inspection reports, the *owner or operator* shall submit the documents in both electronic (PDF only) and paper format within five (5) business days, unless otherwise notified by the Department.

B. Required SWPPP Contents

1. Erosion and sediment control component - All SWPPPs prepared pursuant to this permit shall include erosion and sediment control practices designed in conformance with the technical standard, New York State Standards and Specifications for Erosion and Sediment Control, dated November 2016. Where erosion and sediment control practices are not designed in conformance with the design criteria included in the technical standard, the *owner or operator* must demonstrate *equivalence* to the technical standard. At a minimum, the erosion and sediment control component of the SWPPP shall include the following:
 - a. Background information about the scope of the project, including the location, type and size of project

- b. A site map/construction drawing(s) for the project, including a general location map. At a minimum, the site map shall show the total site area; all improvements; areas of disturbance; areas that will not be disturbed; existing vegetation; on-site and adjacent off-site surface water(s); floodplain/floodway boundaries; wetlands and drainage patterns that could be affected by the *construction activity*; existing and final contours ; locations of different soil types with boundaries; material, waste, borrow or equipment storage areas located on adjacent properties; and location(s) of the stormwater *discharge(s)*;
- c. A description of the soil(s) present at the site, including an identification of the Hydrologic Soil Group (HSG);
- d. A construction phasing plan and sequence of operations describing the intended order of *construction activities*, including clearing and grubbing, excavation and grading, utility and infrastructure installation and any other activity at the site that results in soil disturbance;
- e. A description of the minimum erosion and sediment control practices to be installed or implemented for each *construction activity* that will result in soil disturbance. Include a schedule that identifies the timing of initial placement or implementation of each erosion and sediment control practice and the minimum time frames that each practice should remain in place or be implemented;
- f. A temporary and permanent soil stabilization plan that meets the requirements of this general permit and the technical standard, New York State Standards and Specifications for Erosion and Sediment Control, dated November 2016, for each stage of the project, including initial land clearing and grubbing to project completion and achievement of *final stabilization*;
- g. A site map/construction drawing(s) showing the specific location(s), size(s), and length(s) of each erosion and sediment control practice;
- h. The dimensions, material specifications, installation details, and operation and maintenance requirements for all erosion and sediment control practices. Include the location and sizing of any temporary sediment basins and structural practices that will be used to divert flows from exposed soils;
- i. A maintenance inspection schedule for the contractor(s) identified in Part III.A.6. of this permit, to ensure continuous and effective operation of the erosion and sediment control practices. The maintenance inspection

schedule shall be in accordance with the requirements in the technical standard, New York State Standards and Specifications for Erosion and Sediment Control, dated November 2016;

- j. A description of the pollution prevention measures that will be used to control litter, construction chemicals and construction debris from becoming a *pollutant* source in the stormwater *discharges*;
 - k. A description and location of any stormwater *discharges* associated with industrial activity other than construction at the site, including, but not limited to, stormwater *discharges* from asphalt plants and concrete plants located on the *construction site*; and
 - l. Identification of any elements of the design that are not in conformance with the design criteria in the technical standard, New York State Standards and Specifications for Erosion and Sediment Control, dated November 2016. Include the reason for the deviation or alternative design and provide information which demonstrates that the deviation or alternative design is *equivalent* to the technical standard.
2. Post-construction stormwater management practice component – The *owner or operator* of any construction project identified in Table 2 of Appendix B as needing post-construction stormwater management practices shall prepare a SWPPP that includes practices designed in conformance with the applicable *sizing criteria* in Part I.C.2.a., c. or d. of this permit and the *performance criteria* in the technical standard, New York State Stormwater Management Design Manual dated January 2015

Where post-construction stormwater management practices are not designed in conformance with the *performance criteria* in the technical standard, the *owner or operator* must include in the SWPPP the reason(s) for the deviation or alternative design and provide information which demonstrates that the deviation or alternative design is *equivalent* to the technical standard.

The post-construction stormwater management practice component of the SWPPP shall include the following:

- a. Identification of all post-construction stormwater management practices to be constructed as part of the project. Include the dimensions, material specifications and installation details for each post-construction stormwater management practice;

- b. A site map/construction drawing(s) showing the specific location and size of each post-construction stormwater management practice;
- c. A Stormwater Modeling and Analysis Report that includes:
 - (i) Map(s) showing pre-development conditions, including watershed/subcatchments boundaries, flow paths/routing, and design points;
 - (ii) Map(s) showing post-development conditions, including watershed/subcatchments boundaries, flow paths/routing, design points and post-construction stormwater management practices;
 - (iii) Results of stormwater modeling (i.e. hydrology and hydraulic analysis) for the required storm events. Include supporting calculations (model runs), methodology, and a summary table that compares pre and post-development runoff rates and volumes for the different storm events;
 - (iv) Summary table, with supporting calculations, which demonstrates that each post-construction stormwater management practice has been designed in conformance with the *sizing criteria* included in the Design Manual;
 - (v) Identification of any *sizing criteria* that is not required based on the requirements included in Part I.C. of this permit; and
 - (vi) Identification of any elements of the design that are not in conformance with the *performance criteria* in the Design Manual. Include the reason(s) for the deviation or alternative design and provide information which demonstrates that the deviation or alternative design is *equivalent* to the Design Manual;
- d. Soil testing results and locations (test pits, borings);
- e. Infiltration test results, when required; and
- f. An operations and maintenance plan that includes inspection and maintenance schedules and actions to ensure continuous and effective operation of each post-construction stormwater management practice. The plan shall identify the entity that will be responsible for the long term operation and maintenance of each practice.

3. Enhanced Phosphorus Removal Standards - All construction projects identified in Table 2 of Appendix B that are located in the watersheds identified in Appendix C shall prepare a SWPPP that includes post-construction stormwater management practices designed in conformance with the applicable *sizing criteria* in Part I.C.2. b., c. or d. of this permit and the *performance criteria*, Enhanced Phosphorus Removal Standards included in the Design Manual. At a minimum, the post-construction stormwater management practice component of the SWPPP shall include items 2.a - 2.f. above.

C. Required SWPPP Components by Project Type

Unless otherwise notified by the Department, *owners or operators of construction activities* identified in Table 1 of Appendix B are required to prepare a SWPPP that only includes erosion and sediment control practices designed in conformance with Part III.B.1 of this permit. *Owners or operators of the construction activities* identified in Table 2 of Appendix B shall prepare a SWPPP that also includes post-construction stormwater management practices designed in conformance with Part III.B.2 or 3 of this permit.

Part IV. INSPECTION AND MAINTENANCE REQUIREMENTS

A. General Construction Site Inspection and Maintenance Requirements

1. The *owner or operator* must ensure that all erosion and sediment control practices (including pollution prevention measures) and all post-construction stormwater management practices identified in the SWPPP are inspected and maintained in accordance with Part IV.B. and C. of this permit.
2. The terms of this permit shall not be construed to prohibit the State of New York from exercising any authority pursuant to the ECL, common law or federal law, or prohibit New York State from taking any measures, whether civil or criminal, to prevent violations of the laws of the State of New York or protect the public health and safety and/or the environment.

B. Contractor Maintenance Inspection Requirements

1. The *owner or operator of each construction activity* identified in Tables 1 and 2 of Appendix B shall have a *trained contractor* inspect the erosion and sediment control practices and pollution prevention measures being implemented within the active work area daily to ensure that they are being maintained in effective operating condition at all times. If deficiencies are identified, the contractor shall

begin implementing corrective actions within one business day and shall complete the corrective actions in a reasonable time frame.

2. For construction sites where soil disturbance activities have been temporarily suspended (e.g. winter shutdown) and *temporary stabilization* measures have been applied to all disturbed areas, the *trained contractor* can stop conducting the maintenance inspections. The *trained contractor* shall begin conducting the maintenance inspections in accordance with Part IV.B.1. of this permit as soon as soil disturbance activities resume.
3. For construction sites where soil disturbance activities have been shut down with partial project completion, the *trained contractor* can stop conducting the maintenance inspections if all areas disturbed as of the project shutdown date have achieved *final stabilization* and all post-construction stormwater management practices required for the completed portion of the project have been constructed in conformance with the SWPPP and are operational.

C. Qualified Inspector Inspection Requirements

The *owner or operator* shall have a *qualified inspector* conduct site inspections in conformance with the following requirements:

[Note: The *trained contractor* identified in Part III.A.6. and IV.B. of this permit **cannot** conduct the *qualified inspector* site inspections unless they meet the *qualified inspector* qualifications included in Appendix A. In order to perform these inspections, the *trained contractor* would have to be a:

- licensed Professional Engineer,
 - Certified Professional in Erosion and Sediment Control (CPESC),
 - New York State Erosion and Sediment Control Certificate Program holder
 - Registered Landscape Architect, or
 - someone working under the direct supervision of, and at the same company as, the licensed Professional Engineer or Registered Landscape Architect, provided they have received four (4) hours of Department endorsed training in proper erosion and sediment control principles from a Soil and Water Conservation District, or other Department endorsed entity].
1. A *qualified inspector* shall conduct site inspections for all *construction activities* identified in Tables 1 and 2 of Appendix B, with the exception of:
 - a. the construction of a single family residential subdivision with 25% or less *impervious cover* at total site build-out that involves a soil disturbance of one (1) or more acres of land but less than five (5) acres and is not located

in one of the watersheds listed in Appendix C and not directly discharging to one of the 303(d) segments listed in Appendix E;

- b. the construction of a single family home that involves a soil disturbance of one (1) or more acres of land but less than five (5) acres and is not located in one of the watersheds listed in Appendix C and not directly discharging to one of the 303(d) segments listed in Appendix E;
 - c. construction on agricultural property that involves a soil disturbance of one (1) or more acres of land but less than five (5) acres; and
 - d. *construction activities* located in the watersheds identified in Appendix D that involve soil disturbances between five thousand (5,000) square feet and one (1) acre of land.
2. Unless otherwise notified by the Department, the *qualified inspector* shall conduct site inspections in accordance with the following timetable:
- a. For construction sites where soil disturbance activities are on-going, the *qualified inspector* shall conduct a site inspection at least once every seven (7) calendar days.
 - b. For construction sites where soil disturbance activities are on-going and the *owner or operator* has received authorization in accordance with Part II.D.3 to disturb greater than five (5) acres of soil at any one time, the *qualified inspector* shall conduct at least two (2) site inspections every seven (7) calendar days. The two (2) inspections shall be separated by a minimum of two (2) full calendar days.
 - c. For construction sites where soil disturbance activities have been temporarily suspended (e.g. winter shutdown) and *temporary stabilization* measures have been applied to all disturbed areas, the *qualified inspector* shall conduct a site inspection at least once every thirty (30) calendar days. The *owner or operator* shall notify the DOW Water (SPDES) Program contact at the Regional Office (see contact information in Appendix F) or, in areas under the jurisdiction of a *regulated, traditional land use control MS4*, the *regulated, traditional land use control MS4* (provided the *regulated, traditional land use control MS4* is not the *owner or operator* of the *construction activity*) in writing prior to reducing the frequency of inspections.

- d. For construction sites where soil disturbance activities have been shut down with partial project completion, the *qualified inspector* can stop conducting inspections if all areas disturbed as of the project shutdown date have achieved *final stabilization* and all post-construction stormwater management practices required for the completed portion of the project have been constructed in conformance with the SWPPP and are operational. The *owner or operator* shall notify the DOW Water (SPDES) Program contact at the Regional Office (see contact information in Appendix F) or, in areas under the jurisdiction of a *regulated, traditional land use control MS4*, the *regulated, traditional land use control MS4* (provided the *regulated, traditional land use control MS4* is not the *owner or operator* of the *construction activity*) in writing prior to the shutdown. If soil disturbance activities are not resumed within 2 years from the date of shutdown, the *owner or operator* shall have the *qualified inspector* perform a final inspection and certify that all disturbed areas have achieved *final stabilization*, and all temporary, structural erosion and sediment control measures have been removed; and that all post-construction stormwater management practices have been constructed in conformance with the SWPPP by signing the “*Final Stabilization*” and “*Post-Construction Stormwater Management Practice*” certification statements on the NOT. The *owner or operator* shall then submit the completed NOT form to the address in Part II.B.1 of this permit.
 - e. For construction sites that directly *discharge* to one of the 303(d) segments listed in Appendix E or is located in one of the watersheds listed in Appendix C, the *qualified inspector* shall conduct at least two (2) site inspections every seven (7) calendar days. The two (2) inspections shall be separated by a minimum of two (2) full calendar days.
3. At a minimum, the *qualified inspector* shall inspect all erosion and sediment control practices and pollution prevention measures to ensure integrity and effectiveness, all post-construction stormwater management practices under construction to ensure that they are constructed in conformance with the SWPPP, all areas of disturbance that have not achieved *final stabilization*, all points of *discharge* to natural surface waterbodies located within, or immediately adjacent to, the property boundaries of the *construction site*, and all points of *discharge* from the *construction site*.
 4. The *qualified inspector* shall prepare an inspection report subsequent to each and every inspection. At a minimum, the inspection report shall include and/or address the following:

- a. Date and time of inspection;
- b. Name and title of person(s) performing inspection;
- c. A description of the weather and soil conditions (e.g. dry, wet, saturated) at the time of the inspection;
- d. A description of the condition of the runoff at all points of *discharge* from the *construction site*. This shall include identification of any *discharges* of sediment from the *construction site*. Include *discharges* from conveyance systems (i.e. pipes, culverts, ditches, etc.) and overland flow;
- e. A description of the condition of all natural surface waterbodies located within, or immediately adjacent to, the property boundaries of the *construction site* which receive runoff from disturbed areas. This shall include identification of any *discharges* of sediment to the surface waterbody;
- f. Identification of all erosion and sediment control practices and pollution prevention measures that need repair or maintenance;
- g. Identification of all erosion and sediment control practices and pollution prevention measures that were not installed properly or are not functioning as designed and need to be reinstalled or replaced;
- h. Description and sketch of areas with active soil disturbance activity, areas that have been disturbed but are inactive at the time of the inspection, and areas that have been stabilized (temporary and/or final) since the last inspection;
- i. Current phase of construction of all post-construction stormwater management practices and identification of all construction that is not in conformance with the SWPPP and technical standards;
- j. Corrective action(s) that must be taken to install, repair, replace or maintain erosion and sediment control practices and pollution prevention measures; and to correct deficiencies identified with the construction of the post-construction stormwater management practice(s);
- k. Identification and status of all corrective actions that were required by previous inspection; and

- I. Digital photographs, with date stamp, that clearly show the condition of all practices that have been identified as needing corrective actions. The *qualified inspector* shall attach paper color copies of the digital photographs to the inspection report being maintained onsite within seven (7) calendar days of the date of the inspection. The *qualified inspector* shall also take digital photographs, with date stamp, that clearly show the condition of the practice(s) after the corrective action has been completed. The *qualified inspector* shall attach paper color copies of the digital photographs to the inspection report that documents the completion of the corrective action work within seven (7) calendar days of that inspection.
5. Within one business day of the completion of an inspection, the *qualified inspector* shall notify the *owner or operator* and appropriate contractor or subcontractor identified in Part III.A.6. of this permit of any corrective actions that need to be taken. The contractor or subcontractor shall begin implementing the corrective actions within one business day of this notification and shall complete the corrective actions in a reasonable time frame.
6. All inspection reports shall be signed by the *qualified inspector*. Pursuant to Part II.D.2. of this permit, the inspection reports shall be maintained on site with the SWPPP.

Part V. TERMINATION OF PERMIT COVERAGE

A. Termination of Permit Coverage

1. An *owner or operator* that is eligible to terminate coverage under this permit must submit a completed NOT form to the address in Part II.B.1 of this permit. The NOT form shall be one which is associated with this permit, signed in accordance with Part VII.H of this permit.
2. An *owner or operator* may terminate coverage when one or more the following conditions have been met:
 - a. Total project completion - All *construction activity* identified in the SWPPP has been completed; and all areas of disturbance have achieved *final stabilization*; and all temporary, structural erosion and sediment control measures have been removed; and all post-construction stormwater management practices have been constructed in conformance with the SWPPP and are operational;

- b. Planned shutdown with partial project completion - All soil disturbance activities have ceased; and all areas disturbed as of the project shutdown date have achieved *final stabilization*; and all temporary, structural erosion and sediment control measures have been removed; and all post-construction stormwater management practices required for the completed portion of the project have been constructed in conformance with the SWPPP and are operational;
 - c. A new *owner or operator* has obtained coverage under this permit in accordance with Part II.F. of this permit.
 - d. The *owner or operator* obtains coverage under an alternative SPDES general permit or an individual SPDES permit.
3. For *construction activities* meeting subdivision 2a. or 2b. of this Part, the *owner or operator* shall have the *qualified inspector* perform a final site inspection prior to submitting the NOT. The *qualified inspector* shall, by signing the “*Final Stabilization*” and “Post-Construction Stormwater Management Practice certification statements on the NOT, certify that all the requirements in Part V.A.2.a. or b. of this permit have been achieved.
 4. For *construction activities* that are subject to the requirements of a *regulated, traditional land use control MS4* and meet subdivision 2a. or 2b. of this Part, the *owner or operator* shall have the *regulated, traditional land use control MS4* sign the “MS4 Acceptance” statement on the NOT in accordance with the requirements in Part VII.H. of this permit. The *regulated, traditional land use control MS4* official, by signing this statement, has determined that it is acceptable for the *owner or operator* to submit the NOT in accordance with the requirements of this Part. The *regulated, traditional land use control MS4* can make this determination by performing a final site inspection themselves or by accepting the *qualified inspector’s* final site inspection certification(s) required in Part V.A.3. of this permit.
 5. For *construction activities* that require post-construction stormwater management practices and meet subdivision 2a. of this Part, the *owner or operator* must, prior to submitting the NOT, ensure one of the following:
 - a. the post-construction stormwater management practice(s) and any right-of-way(s) needed to maintain such practice(s) have been deeded to the municipality in which the practice(s) is located,

- b. an executed maintenance agreement is in place with the municipality that will maintain the post-construction stormwater management practice(s),
- c. for post-construction stormwater management practices that are privately owned, the *owner or operator* has a mechanism in place that requires operation and maintenance of the practice(s) in accordance with the operation and maintenance plan, such as a deed covenant in the *owner or operator's* deed of record,
- d. for post-construction stormwater management practices that are owned by a public or private institution (e.g. school, university, hospital), government agency or authority, or public utility; the *owner or operator* has policy and procedures in place that ensures operation and maintenance of the practices in accordance with the operation and maintenance plan.

Part VI. REPORTING AND RETENTION RECORDS

A. Record Retention

The *owner or operator* shall retain a copy of the NOI, NOI Acknowledgment Letter, SWPPP, MS4 SWPPP Acceptance form and any inspection reports that were prepared in conjunction with this permit for a period of at least five (5) years from the date that the Department receives a complete NOT submitted in accordance with Part V. of this general permit.

B. Addresses

With the exception of the NOI, NOT, and MS4 SWPPP Acceptance form (which must be submitted to the address referenced in Part II.B.1 of this permit), all written correspondence requested by the Department, including individual permit applications, shall be sent to the address of the appropriate DOW Water (SPDES) Program contact at the Regional Office listed in Appendix F.

Part VII. STANDARD PERMIT CONDITIONS

A. Duty to Comply

The *owner or operator* must comply with all conditions of this permit. All contractors and subcontractors associated with the project must comply with the terms of the SWPPP. Any non-compliance with this permit constitutes a violation of the Clean Water

Act (CWA) and the ECL and is grounds for an enforcement action against the *owner or operator* and/or the contractor/subcontractor; permit revocation, suspension or modification; or denial of a permit renewal application. Upon a finding of significant non-compliance with this permit or the applicable SWPPP, the Department may order an immediate stop to all *construction activity* at the site until the non-compliance is remedied. The stop work order shall be in writing, shall describe the non-compliance in detail, and shall be sent to the *owner or operator*.

If any human remains or archaeological remains are encountered during excavation, the *owner or operator* must immediately cease, or cause to cease, all *construction activity* in the area of the remains and notify the appropriate Regional Water Engineer (RWE). *Construction activity* shall not resume until written permission to do so has been received from the RWE.

B. Continuation of the Expired General Permit

This permit expires five (5) years from the effective date. If a new general permit is not issued prior to the expiration of this general permit, an *owner or operator* with coverage under this permit may continue to operate and *discharge* in accordance with the terms and conditions of this general permit, if it is extended pursuant to the State Administrative Procedure Act and 6 NYCRR Part 621, until a new general permit is issued.

C. Enforcement

Failure of the *owner or operator*, its contractors, subcontractors, agents and/or assigns to strictly adhere to any of the permit requirements contained herein shall constitute a violation of this permit. There are substantial criminal, civil, and administrative penalties associated with violating the provisions of this permit. Fines of up to \$37,500 per day for each violation and imprisonment for up to fifteen (15) years may be assessed depending upon the nature and degree of the offense.

D. Need to Halt or Reduce Activity Not a Defense

It shall not be a defense for an *owner or operator* in an enforcement action that it would have been necessary to halt or reduce the *construction activity* in order to maintain compliance with the conditions of this permit.

E. Duty to Mitigate

The *owner or operator* and its contractors and subcontractors shall take all reasonable steps to *minimize* or prevent any *discharge* in violation of this permit which has a reasonable likelihood of adversely affecting human health or the environment.

F. Duty to Provide Information

The *owner or operator* shall furnish to the Department, within a reasonable specified time period of a written request, all documentation necessary to demonstrate eligibility and any information to determine compliance with this permit or to determine whether cause exists for modifying or revoking this permit, or suspending or denying coverage under this permit, in accordance with the terms and conditions of this permit. The NOI, SWPPP and inspection reports required by this permit are public documents that the *owner or operator* must make available for review and copying by any person within five (5) business days of the *owner or operator* receiving a written request by any such person to review these documents. Copying of documents will be done at the requester's expense.

G. Other Information

When the *owner or operator* becomes aware that they failed to submit any relevant facts, or submitted incorrect information in the NOI or in any of the documents required by this permit, or have made substantive revisions to the SWPPP (e.g. the scope of the project changes significantly, the type of post-construction stormwater management practice(s) changes, there is a reduction in the sizing of the post-construction stormwater management practice, or there is an increase in the disturbance area or *impervious area*), which were not reflected in the original NOI submitted to the Department, they shall promptly submit such facts or information to the Department using the contact information in Part II.A. of this permit. Failure of the *owner or operator* to correct or supplement any relevant facts within five (5) business days of becoming aware of the deficiency shall constitute a violation of this permit.

H. Signatory Requirements

1. All NOIs and NOTs shall be signed as follows:
 - a. For a corporation these forms shall be signed by a responsible corporate officer. For the purpose of this section, a responsible corporate officer means:

- (i) a president, secretary, treasurer, or vice-president of the corporation in charge of a principal business function, or any other person who performs similar policy or decision-making functions for the corporation; or
 - (ii) the manager of one or more manufacturing, production or operating facilities, provided the manager is authorized to make management decisions which govern the operation of the regulated facility including having the explicit or implicit duty of making major capital investment recommendations, and initiating and directing other comprehensive measures to assure long term environmental compliance with environmental laws and regulations; the manager can ensure that the necessary systems are established or actions taken to gather complete and accurate information for permit application requirements; and where authority to sign documents has been assigned or delegated to the manager in accordance with corporate procedures;
 - b. For a partnership or sole proprietorship these forms shall be signed by a general partner or the proprietor, respectively; or
 - c. For a municipality, State, Federal, or other public agency these forms shall be signed by either a principal executive officer or ranking elected official. For purposes of this section, a principal executive officer of a Federal agency includes:
 - (i) the chief executive officer of the agency, or
 - (ii) a senior executive officer having responsibility for the overall operations of a principal geographic unit of the agency (e.g., Regional Administrators of EPA).
2. The SWPPP and other information requested by the Department shall be signed by a person described in Part VII.H.1. of this permit or by a duly authorized representative of that person. A person is a duly authorized representative only if:
- a. The authorization is made in writing by a person described in Part VII.H.1. of this permit;
 - b. The authorization specifies either an individual or a position having responsibility for the overall operation of the regulated facility or activity, such as the position of plant manager, operator of a well or a well field,

superintendent, position of *equivalent* responsibility, or an individual or position having overall responsibility for environmental matters for the company. (A duly authorized representative may thus be either a named individual or any individual occupying a named position) and,

- c. The written authorization shall include the name, title and signature of the authorized representative and be attached to the SWPPP.
3. All inspection reports shall be signed by the *qualified inspector* that performs the inspection.
4. The MS4 SWPPP Acceptance form shall be signed by the principal executive officer or ranking elected official from the *regulated, traditional land use control MS4*, or by a duly authorized representative of that person.

It shall constitute a permit violation if an incorrect and/or improper signatory authorizes any required forms, SWPPP and/or inspection reports.

I. Property Rights

The issuance of this permit does not convey any property rights of any sort, nor any exclusive privileges, nor does it authorize any injury to private property nor any invasion of personal rights, nor any infringement of Federal, State or local laws or regulations. *Owners or operators* must obtain any applicable conveyances, easements, licenses and/or access to real property prior to *commencing construction activity*.

J. Severability

The provisions of this permit are severable, and if any provision of this permit, or the application of any provision of this permit to any circumstance, is held invalid, the application of such provision to other circumstances, and the remainder of this permit shall not be affected thereby.

K. Requirement to Obtain Coverage Under an Alternative Permit

1. The Department may require any owner or operator authorized by this permit to apply for and/or obtain either an individual SPDES permit or another SPDES general permit. When the Department requires any discharger authorized by a general permit to apply for an individual SPDES permit, it shall notify the discharger in writing that a permit application is required. This notice shall

include a brief statement of the reasons for this decision, an application form, a statement setting a time frame for the owner or operator to file the application for an individual SPDES permit, and a deadline, not sooner than 180 days from owner or operator receipt of the notification letter, whereby the authorization to discharge under this general permit shall be terminated. Applications must be submitted to the appropriate Permit Administrator at the Regional Office. The Department may grant additional time upon demonstration, to the satisfaction of the Department, that additional time to apply for an alternative authorization is necessary or where the Department has not provided a permit determination in accordance with Part 621 of this Title.

2. When an individual SPDES permit is issued to a discharger authorized to *discharge* under a general SPDES permit for the same *discharge(s)*, the general permit authorization for outfalls authorized under the individual SPDES permit is automatically terminated on the effective date of the individual permit unless termination is earlier in accordance with 6 NYCRR Part 750.

L. Proper Operation and Maintenance

The *owner or operator* shall at all times properly operate and maintain all facilities and systems of treatment and control (and related appurtenances) which are installed or used by the *owner or operator* to achieve compliance with the conditions of this permit and with the requirements of the SWPPP.

M. Inspection and Entry

The *owner or operator* shall allow an authorized representative of the Department, EPA, applicable county health department, or, in the case of a *construction site* which *discharges* through an *MS4*, an authorized representative of the *MS4* receiving the discharge, upon the presentation of credentials and other documents as may be required by law, to:

1. Enter upon the owner's or operator's premises where a regulated facility or activity is located or conducted or where records must be kept under the conditions of this permit;
2. Have access to and copy at reasonable times, any records that must be kept under the conditions of this permit; and

3. Inspect at reasonable times any facilities or equipment (including monitoring and control equipment), practices or operations regulated or required by this permit.
4. Sample or monitor at reasonable times, for purposes of assuring permit compliance or as otherwise authorized by the Act or ECL, any substances or parameters at any location.

N. Permit Actions

This permit may, at any time, be modified, suspended, revoked, or renewed by the Department in accordance with 6 NYCRR Part 621. The filing of a request by the *owner or operator* for a permit modification, revocation and reissuance, termination, a notification of planned changes or anticipated noncompliance does not limit, diminish and/or stay compliance with any terms of this permit.

O. Definitions

Definitions of key terms are included in Appendix A of this permit.

P. Re-Opener Clause

1. If there is evidence indicating potential or realized impacts on water quality due to any stormwater discharge associated with construction activity covered by this permit, the owner or operator of such discharge may be required to obtain an individual permit or alternative general permit in accordance with Part VII.K. of this permit or the permit may be modified to include different limitations and/or requirements.
2. Any Department initiated permit modification, suspension or revocation will be conducted in accordance with 6 NYCRR Part 621, 6 NYCRR 750-1.18, and 6 NYCRR 750-1.20.

Q. Penalties for Falsification of Forms and Reports

In accordance with 6NYCRR Part 750-2.4 and 750-2.5, any person who knowingly makes any false material statement, representation, or certification in any application, record, report or other document filed or required to be maintained under this permit, including reports of compliance or noncompliance shall, upon conviction, be punished in accordance with ECL §71-1933 and or Articles 175 and 210 of the New York State Penal Law.

R. Other Permits

Nothing in this permit relieves the *owner or operator* from a requirement to obtain any other permits required by law.

APPENDIX A – Acronyms and Definitions

Acronyms

APO – Agency Preservation Officer
BMP – Best Management Practice
CPESC – Certified Professional in Erosion and Sediment Control
Cpv – Channel Protection Volume
CWA – Clean Water Act (or the Federal Water Pollution Control Act, 33 U.S.C. §1251 et seq)
DOW – Division of Water
EAF – Environmental Assessment Form
ECL - Environmental Conservation Law
EPA – U. S. Environmental Protection Agency
HSG – Hydrologic Soil Group
MS4 – Municipal Separate Storm Sewer System
NOI – Notice of Intent
NOT – Notice of Termination
NPDES – National Pollutant Discharge Elimination System
OPRHP – Office of Parks, Recreation and Historic Places
Qf – Extreme Flood
Qp – Overbank Flood
RRv – Runoff Reduction Volume
RWE – Regional Water Engineer
SEQR – State Environmental Quality Review
SEQRA - State Environmental Quality Review Act
SHPA – State Historic Preservation Act
SPDES – State Pollutant Discharge Elimination System
SWPPP – Stormwater Pollution Prevention Plan
TMDL – Total Maximum Daily Load
UPA – Uniform Procedures Act
USDA – United States Department of Agriculture
WQv – Water Quality Volume

Definitions

All definitions in this section are solely for the purposes of this permit.

Agricultural Building – a structure designed and constructed to house farm implements, hay, grain, poultry, livestock or other horticultural products; excluding any structure designed, constructed or used, in whole or in part, for human habitation, as a place of employment where agricultural products are processed, treated or packaged, or as a place used by the public.

Agricultural Property – means the land for construction of a barn, *agricultural building*, silo, stockyard, pen or other structural practices identified in Table II in the “Agricultural Management Practices Catalog for Nonpoint Source Pollution in New York State” prepared by the Department in cooperation with agencies of New York Nonpoint Source Coordinating Committee (dated June 2007).

Alter Hydrology from Pre to Post-Development Conditions - means the post-development peak flow rate(s) has increased by more than 5% of the pre-developed condition for the design storm of interest (e.g. 10 yr and 100 yr).

Combined Sewer - means a sewer that is designed to collect and convey both “sewage” and “stormwater”.

Commence (Commencement of) Construction Activities - means the initial disturbance of soils associated with clearing, grading or excavation activities; or other construction related activities that disturb or expose soils such as demolition, stockpiling of fill material, and the initial installation of erosion and sediment control practices required in the SWPPP. See definition for “*Construction Activity(ies)*” also.

Construction Activity(ies) - means any clearing, grading, excavation, filling, demolition or stockpiling activities that result in soil disturbance. Clearing activities can include, but are not limited to, logging equipment operation, the cutting and skidding of trees, stump removal and/or brush root removal. Construction activity does not include routine maintenance that is performed to maintain the original line and grade, hydraulic capacity, or original purpose of a facility.

Construction Site – means the land area where *construction activity(ies)* will occur. See definition for “*Commence (Commencement of) Construction Activities*” and “*Larger Common Plan of Development or Sale*” also.

Dewatering – means the act of draining rainwater and/or groundwater from building foundations, vaults or excavations/trenches.

Direct Discharge (to a specific surface waterbody) - means that runoff flows from a *construction site* by overland flow and the first point of discharge is the specific surface waterbody, or runoff flows from a *construction site* to a separate storm sewer system

and the first point of discharge from the separate storm sewer system is the specific surface waterbody.

Discharge(s) - means any addition of any pollutant to waters of the State through an outlet or *point source*.

Embankment –means an earthen or rock slope that supports a road/highway.

Endangered or Threatened Species – see 6 NYCRR Part 182 of the Department’s rules and regulations for definition of terms and requirements.

Environmental Conservation Law (ECL) - means chapter 43-B of the Consolidated Laws of the State of New York, entitled the Environmental Conservation Law.

Equivalent (Equivalence) – means that the practice or measure meets all the performance, longevity, maintenance, and safety objectives of the technical standard and will provide an equal or greater degree of water quality protection.

Final Stabilization - means that all soil disturbance activities have ceased and a uniform, perennial vegetative cover with a density of eighty (80) percent over the entire pervious surface has been established; or other equivalent stabilization measures, such as permanent landscape mulches, rock rip-rap or washed/crushed stone have been applied on all disturbed areas that are not covered by permanent structures, concrete or pavement.

General SPDES permit - means a SPDES permit issued pursuant to 6 NYCRR Part 750-1.21 and Section 70-0117 of the ECL authorizing a category of discharges.

Groundwater(s) - means waters in the saturated zone. The saturated zone is a subsurface zone in which all the interstices are filled with water under pressure greater than that of the atmosphere. Although the zone may contain gas-filled interstices or interstices filled with fluids other than water, it is still considered saturated.

Historic Property – means any building, structure, site, object or district that is listed on the State or National Registers of Historic Places or is determined to be eligible for listing on the State or National Registers of Historic Places.

Impervious Area (Cover) - means all impermeable surfaces that cannot effectively infiltrate rainfall. This includes paved, concrete and gravel surfaces (i.e. parking lots, driveways, roads, runways and sidewalks); building rooftops and miscellaneous impermeable structures such as patios, pools, and sheds.

Infeasible – means not technologically possible, or not economically practicable and achievable in light of best industry practices.

Larger Common Plan of Development or Sale - means a contiguous area where multiple separate and distinct *construction activities* are occurring, or will occur, under one plan. The term “plan” in “larger common plan of development or sale” is broadly defined as any announcement or piece of documentation (including a sign, public notice or hearing, marketing plan, advertisement, drawing, permit application, State Environmental Quality Review Act (SEQRA) environmental assessment form or other documents, zoning request, computer design, etc.) or physical demarcation (including boundary signs, lot stakes, surveyor markings, etc.) indicating that *construction activities* may occur on a specific plot.

For discrete construction projects that are located within a larger common plan of development or sale that are at least 1/4 mile apart, each project can be treated as a separate plan of development or sale provided any interconnecting road, pipeline or utility project that is part of the same “common plan” is not concurrently being disturbed.

Minimize – means reduce and/or eliminate to the extent achievable using control measures (including best management practices) that are technologically available and economically practicable and achievable in light of best industry practices.

Municipal Separate Storm Sewer (MS4) - a conveyance or system of conveyances (including roads with drainage systems, municipal streets, catch basins, curbs, gutters, ditches, man-made channels, or storm drains):

- (i) Owned or operated by a State, city, town, borough, county, parish, district, association, or other public body (created by or pursuant to State law) having jurisdiction over disposal of sewage, industrial wastes, stormwater, or other wastes, including special districts under State law such as a sewer district, flood control district or drainage district, or similar entity, or an Indian tribe or an authorized Indian tribal organization, or a designated and approved management agency under section 208 of the CWA that discharges to surface waters of the State;
- (ii) Designed or used for collecting or conveying stormwater;
- (iii) Which is not a *combined sewer*; and
- (iv) Which is not part of a Publicly Owned Treatment Works (POTW) as defined at 40 CFR 122.2.

National Pollutant Discharge Elimination System (NPDES) - means the national system for the issuance of wastewater and stormwater permits under the Federal Water Pollution Control Act (Clean Water Act).

Natural Buffer – means an undisturbed area with natural cover running along a surface water (e.g. wetland, stream, river, lake, etc.).

New Development – means any land disturbance that does not meet the definition of Redevelopment Activity included in this appendix.

New York State Erosion and Sediment Control Certificate Program – a certificate program that establishes and maintains a process to identify and recognize individuals who are capable of developing, designing, inspecting and maintaining erosion and sediment control plans on projects that disturb soils in New York State. The certificate program is administered by the New York State Conservation District Employees Association.

NOI Acknowledgment Letter - means the letter that the Department sends to an owner or operator to acknowledge the Department's receipt and acceptance of a complete Notice of Intent. This letter documents the owner's or operator's authorization to discharge in accordance with the general permit for stormwater discharges from *construction activity*.

Nonpoint Source - means any source of water pollution or pollutants which is not a discrete conveyance or *point source* permitted pursuant to Title 7 or 8 of Article 17 of the Environmental Conservation Law (see ECL Section 17-1403).

Overbank –means flow events that exceed the capacity of the stream channel and spill out into the adjacent floodplain.

Owner or Operator - means the person, persons or legal entity which owns or leases the property on which the *construction activity* is occurring; an entity that has operational control over the construction plans and specifications, including the ability to make modifications to the plans and specifications; and/or an entity that has day-to-day operational control of those activities at a project that are necessary to ensure compliance with the permit conditions.

Performance Criteria – means the design criteria listed under the “Required Elements” sections in Chapters 5, 6 and 10 of the technical standard, New York State Stormwater Management Design Manual, dated January 2015. It does not include the Sizing Criteria (i.e. WQv, RRv, Cpv, Qp and Qf) in Part I.C.2. of the permit.

Point Source - means any discernible, confined and discrete conveyance, including but not limited to any pipe, ditch, channel, tunnel, conduit, well, discrete fissure, container, rolling stock, concentrated animal feeding operation, vessel or other floating craft, or landfill leachate collection system from which *pollutants* are or may be discharged.

Pollutant - means dredged spoil, filter backwash, solid waste, incinerator residue, sewage, garbage, sewage sludge, munitions, chemical wastes, biological materials, radioactive materials, heat, wrecked or discarded equipment, rock, sand and industrial, municipal, agricultural waste and ballast discharged into water; which may cause or might reasonably be expected to cause pollution of the waters of the state in contravention of the standards or guidance values adopted as provided in 6 NYCRR Parts 700 et seq .

Qualified Inspector - means a person that is knowledgeable in the principles and practices of erosion and sediment control, such as a licensed Professional Engineer, Certified Professional in Erosion and Sediment Control (CPESC), Registered Landscape Architect, New York State Erosion and Sediment Control Certificate Program holder or other Department endorsed individual(s).

It can also mean someone working under the direct supervision of, and at the same company as, the licensed Professional Engineer or Registered Landscape Architect, provided that person has training in the principles and practices of erosion and sediment control. Training in the principles and practices of erosion and sediment control means that the individual working under the direct supervision of the licensed Professional Engineer or Registered Landscape Architect has received four (4) hours of Department endorsed training in proper erosion and sediment control principles from a Soil and Water Conservation District, or other Department endorsed entity. After receiving the initial training, the individual working under the direct supervision of the licensed Professional Engineer or Registered Landscape Architect shall receive four (4) hours of training every three (3) years.

It can also mean a person that meets the *Qualified Professional* qualifications in addition to the *Qualified Inspector* qualifications.

Note: Inspections of any post-construction stormwater management practices that include structural components, such as a dam for an impoundment, shall be performed by a licensed Professional Engineer.

Qualified Professional - means a person that is knowledgeable in the principles and practices of stormwater management and treatment, such as a licensed Professional Engineer, Registered Landscape Architect or other Department endorsed individual(s). Individuals preparing SWPPPs that require the post-construction stormwater management practice component must have an understanding of the principles of hydrology, water quality management practice design, water quantity control design, and, in many cases, the principles of hydraulics. All components of the SWPPP that involve the practice of engineering, as defined by the NYS Education Law (see Article 145), shall be prepared by, or under the direct supervision of, a professional engineer licensed to practice in the State of New York.

Redevelopment Activity(ies) – means the disturbance and reconstruction of existing impervious area, including impervious areas that were removed from a project site within five (5) years of preliminary project plan submission to the local government (i.e. site plan, subdivision, etc.).

Regulated, Traditional Land Use Control MS4 - means a city, town or village with land use control authority that is authorized to discharge under New York State DEC's

SPDES General Permit For Stormwater Discharges from Municipal Separate Stormwater Sewer Systems (MS4s) or the City of New York's Individual SPDES Permit for their Municipal Separate Storm Sewer Systems (NY-0287890).

Routine Maintenance Activity - means *construction activity* that is performed to maintain the original line and grade, hydraulic capacity, or original purpose of a facility, including, but not limited to:

- Re-grading of gravel roads or parking lots,
- Cleaning and shaping of existing roadside ditches and culverts that maintains the approximate original line and grade, and hydraulic capacity of the ditch,
- Cleaning and shaping of existing roadside ditches that does not maintain the approximate original grade, hydraulic capacity and purpose of the ditch if the changes to the line and grade, hydraulic capacity or purpose of the ditch are installed to improve water quality and quantity controls (e.g. installing grass lined ditch),
- Placement of aggregate shoulder backing that stabilizes the transition between the road shoulder and the ditch or *embankment*,
- Full depth milling and filling of existing asphalt pavements, replacement of concrete pavement slabs, and similar work that does not expose soil or disturb the bottom six (6) inches of subbase material,
- Long-term use of equipment storage areas at or near highway maintenance facilities,
- Removal of sediment from the edge of the highway to restore a previously existing sheet-flow drainage connection from the highway surface to the highway ditch or *embankment*,
- Existing use of Canal Corp owned upland disposal sites for the canal, and
- Replacement of curbs, gutters, sidewalks and guide rail posts.

Site limitations – means site conditions that prevent the use of an infiltration technique and or infiltration of the total WQv. Typical site limitations include: seasonal high groundwater, shallow depth to bedrock, and soils with an infiltration rate less than 0.5 inches/hour. The existence of site limitations shall be confirmed and documented using actual field testing (i.e. test pits, soil borings, and infiltration test) or using information from the most current United States Department of Agriculture (USDA) Soil Survey for the County where the project is located.

Sizing Criteria – means the criteria included in Part I.C.2 of the permit that are used to size post-construction stormwater management control practices. The criteria include; Water Quality Volume (WQv), Runoff Reduction Volume (RRv), Channel Protection Volume (Cpv), *Overbank Flood* (Qp), and Extreme Flood (Qf).

State Pollutant Discharge Elimination System (SPDES) - means the system established pursuant to Article 17 of the ECL and 6 NYCRR Part 750 for issuance of permits authorizing discharges to the waters of the state.

Steep Slope – means land area designated on the current United States Department of Agriculture (“USDA”) Soil Survey as Soil Slope Phase “D”, (provided the map unit name is inclusive of slopes greater than 25%) , or Soil Slope Phase E or F, (regardless of the map unit name), or a combination of the three designations.

Streambank – as used in this permit, means the terrain alongside the bed of a creek or stream. The bank consists of the sides of the channel, between which the flow is confined.

Stormwater Pollution Prevention Plan (SWPPP) – means a project specific report, including construction drawings, that among other things: describes the construction activity(ies), identifies the potential sources of pollution at the *construction site*; describes and shows the stormwater controls that will be used to control the pollutants (i.e. erosion and sediment controls; for many projects, includes post-construction stormwater management controls); and identifies procedures the *owner or operator* will implement to comply with the terms and conditions of the permit. See Part III of the permit for a complete description of the information that must be included in the SWPPP.

Surface Waters of the State - shall be construed to include lakes, bays, sounds, ponds, impounding reservoirs, springs, rivers, streams, creeks, estuaries, marshes, inlets, canals, the Atlantic ocean within the territorial seas of the state of New York and all other bodies of surface water, natural or artificial, inland or coastal, fresh or salt, public or private (except those private waters that do not combine or effect a junction with natural surface waters), which are wholly or partially within or bordering the state or within its jurisdiction. Waters of the state are further defined in 6 NYCRR Parts 800 to 941.

Temporarily Ceased – means that an existing disturbed area will not be disturbed again within 14 calendar days of the previous soil disturbance.

Temporary Stabilization - means that exposed soil has been covered with material(s) as set forth in the technical standard, New York Standards and Specifications for Erosion and Sediment Control, to prevent the exposed soil from eroding. The materials can include, but are not limited to, mulch, seed and mulch, and erosion control mats (e.g. jute twisted yarn, excelsior wood fiber mats).

Total Maximum Daily Loads (TMDLs) - A TMDL is the sum of the allowable loads of a single pollutant from all contributing point and *nonpoint sources*. It is a calculation of the maximum amount of a pollutant that a waterbody can receive on a daily basis and still meet *water quality standards*, and an allocation of that amount to the pollutant's sources. A TMDL stipulates wasteload allocations (WLAs) for *point source* discharges, load allocations (LAs) for *nonpoint sources*, and a margin of safety (MOS).

Trained Contractor - means an employee from the contracting (construction) company, identified in Part III.A.6., that has received four (4) hours of Department endorsed

training in proper erosion and sediment control principles from a Soil and Water Conservation District, or other Department endorsed entity. After receiving the initial training, the *trained contractor* shall receive four (4) hours of training every three (3) years.

It can also mean an employee from the contracting (construction) company, identified in Part III.A.6., that meets the *qualified inspector* qualifications (e.g. licensed Professional Engineer, Certified Professional in Erosion and Sediment Control (CPESC), Registered Landscape Architect, New York State Erosion and Sediment Control Certificate Program holder, or someone working under the direct supervision of, and at the same company as, the licensed Professional Engineer or Registered Landscape Architect, provided they have received four (4) hours of Department endorsed training in proper erosion and sediment control principles from a Soil and Water Conservation District, or other Department endorsed entity).

The *trained contractor* is responsible for the day to day implementation of the SWPPP.

Uniform Procedures Act (UPA) Permit - means a permit required under 6 NYCRR Part 621 of the Environmental Conservation Law (ECL), Article 70.

Water Quality Standard - means such measures of purity or quality for any waters in relation to their reasonable and necessary use as promulgated in 6 NYCRR Part 700 et seq.

APPENDIX B – Required SWPPP Components by Project Type

**Table 1
Construction Activities that Require the Preparation of a SWPPP That Only
Includes Erosion and Sediment Controls**

<p>The following construction activities that involve soil disturbances of one (1) or more acres of land, but less than five (5) acres:</p> <ul style="list-style-type: none"> • Single family home <u>not</u> located in one of the watersheds listed in Appendix C or <u>not directly discharging</u> to one of the 303(d) segments listed in Appendix E • Single family residential subdivisions with 25% or less impervious cover at total site build-out and <u>not</u> located in one of the watersheds listed in Appendix C and <u>not</u> directly discharging to one of the 303(d) segments listed in Appendix E • Construction of a barn or other <i>agricultural building</i>, silo, stock yard or pen.
<p>The following construction activities that involve soil disturbances between five thousand (5000) square feet and one (1) acre of land:</p> <p>All construction activities located in the watersheds identified in Appendix D that involve soil disturbances between five thousand (5,000) square feet and one (1) acre of land.</p>
<p>The following construction activities that involve soil disturbances of one (1) or more acres of land:</p> <ul style="list-style-type: none"> • Installation of underground, linear utilities; such as gas lines, fiber-optic cable, cable TV, electric, telephone, sewer mains, and water mains • Environmental enhancement projects, such as wetland mitigation projects, stormwater retrofits and stream restoration projects • Pond construction • Linear bike paths running through areas with vegetative cover, including bike paths surfaced with an impervious cover • Cross-country ski trails and walking/hiking trails • Sidewalk, bike path or walking path projects, surfaced with an impervious cover, that are not part of residential, commercial or institutional development; • Sidewalk, bike path or walking path projects, surfaced with an impervious cover, that include incidental shoulder or curb work along an existing highway to support construction of the sidewalk, bike path or walking path. • Slope stabilization projects • Slope flattening that changes the grade of the site, but does not significantly change the runoff characteristics

Table 1 (Continued) CONSTRUCTION ACTIVITIES THAT REQUIRE THE PREPARATION OF A SWPPP THAT ONLY INCLUDES EROSION AND SEDIMENT CONTROLS

The following construction activities that involve soil disturbances of one (1) or more acres of land:

- Spoil areas that will be covered with vegetation
- Vegetated open space projects (i.e. recreational parks, lawns, meadows, fields, downhill ski trails) excluding projects that *alter hydrology from pre to post development* conditions,
- Athletic fields (natural grass) that do not include the construction or reconstruction of *impervious area* and do not *alter hydrology from pre to post development* conditions
- Demolition project where vegetation will be established, and no redevelopment is planned
- Overhead electric transmission line project that does not include the construction of permanent access roads or parking areas surfaced with *impervious cover*
- Structural practices as identified in Table II in the "Agricultural Management Practices Catalog for Nonpoint Source Pollution in New York State", excluding projects that involve soil disturbances of greater than five acres and construction activities that include the construction or reconstruction of impervious area
- Temporary access roads, median crossovers, detour roads, lanes, or other temporary impervious areas that will be restored to pre-construction conditions once the construction activity is complete

Table 2
CONSTRUCTION ACTIVITIES THAT REQUIRE THE PREPARATION OF A SWPPP THAT INCLUDES
POST-CONSTRUCTION STORMWATER MANAGEMENT PRACTICES

The following construction activities that involve soil disturbances of one (1) or more acres of land:

- Single family home located in one of the watersheds listed in Appendix C or *directly discharging* to one of the 303(d) segments listed in Appendix E
- Single family home that disturbs five (5) or more acres of land
- Single family residential subdivisions located in one of the watersheds listed in Appendix C or *directly discharging* to one of the 303(d) segments listed in Appendix E
- Single family residential subdivisions that involve soil disturbances of between one (1) and five (5) acres of land with greater than 25% impervious cover at total site build-out
- Single family residential subdivisions that involve soil disturbances of five (5) or more acres of land, and single family residential subdivisions that involve soil disturbances of less than five (5) acres that are part of a larger common plan of development or sale that will ultimately disturb five or more acres of land
- Multi-family residential developments; includes duplexes, townhomes, condominiums, senior housing complexes, apartment complexes, and mobile home parks
- Airports
- Amusement parks
- Breweries, cideries, and wineries, including establishments constructed on agricultural land
- Campgrounds
- Cemeteries that include the construction or reconstruction of impervious area (>5% of disturbed area) or *alter the hydrology from pre to post development* conditions
- Commercial developments
- Churches and other places of worship
- Construction of a barn or other *agricultural building* (e.g. silo) and structural practices as identified in Table II in the "Agricultural Management Practices Catalog for Nonpoint Source Pollution in New York State" that include the construction or reconstruction of *impervious area*, excluding projects that involve soil disturbances of less than five acres.
- Golf courses
- Institutional development; includes hospitals, prisons, schools and colleges
- Industrial facilities; includes industrial parks
- Landfills
- Municipal facilities; includes highway garages, transfer stations, office buildings, POTW's, water treatment plants, and water storage tanks
- Office complexes
- Playgrounds that include the construction or reconstruction of impervious area
- Sports complexes
- Racetracks; includes racetracks with earthen (dirt) surface
- Road construction or reconstruction, including roads constructed as part of the construction activities listed in Table 1

Table 2 (Continued)

CONSTRUCTION ACTIVITIES THAT REQUIRE THE PREPARATION OF A SWPPP THAT INCLUDES POST-CONSTRUCTION STORMWATER MANAGEMENT PRACTICES

The following construction activities that involve soil disturbances of one (1) or more acres of land:

- Parking lot construction or reconstruction, including parking lots constructed as part of the construction activities listed in Table 1
- Athletic fields (natural grass) that include the construction or reconstruction of impervious area (>5% of disturbed area) or *alter the hydrology from pre to post development* conditions
- Athletic fields with artificial turf
- Permanent access roads, parking areas, substations, compressor stations and well drilling pads, surfaced with *impervious cover*, and constructed as part of an over-head electric transmission line project, wind-power project, cell tower project, oil or gas well drilling project, sewer or water main project or other linear utility project
- Sidewalk, bike path or walking path projects, surfaced with an impervious cover, that are part of a residential, commercial or institutional development
- Sidewalk, bike path or walking path projects, surfaced with an impervious cover, that are part of a highway construction or reconstruction project
- All other construction activities that include the construction or reconstruction of *impervious area* or *alter the hydrology from pre to post development* conditions, and are not listed in Table 1

APPENDIX C – Watersheds Requiring Enhanced Phosphorus Removal

Watersheds where *owners or operators* of construction activities identified in Table 2 of Appendix B must prepare a SWPPP that includes post-construction stormwater management practices designed in conformance with the Enhanced Phosphorus Removal Standards included in the technical standard, New York State Stormwater Management Design Manual (“Design Manual”).

- Entire New York City Watershed located east of the Hudson River - Figure 1
- Onondaga Lake Watershed - Figure 2
- Greenwood Lake Watershed -Figure 3
- Oscawana Lake Watershed – Figure 4
- Kinderhook Lake Watershed – Figure 5

Figure 1 - New York City Watershed East of the Hudson

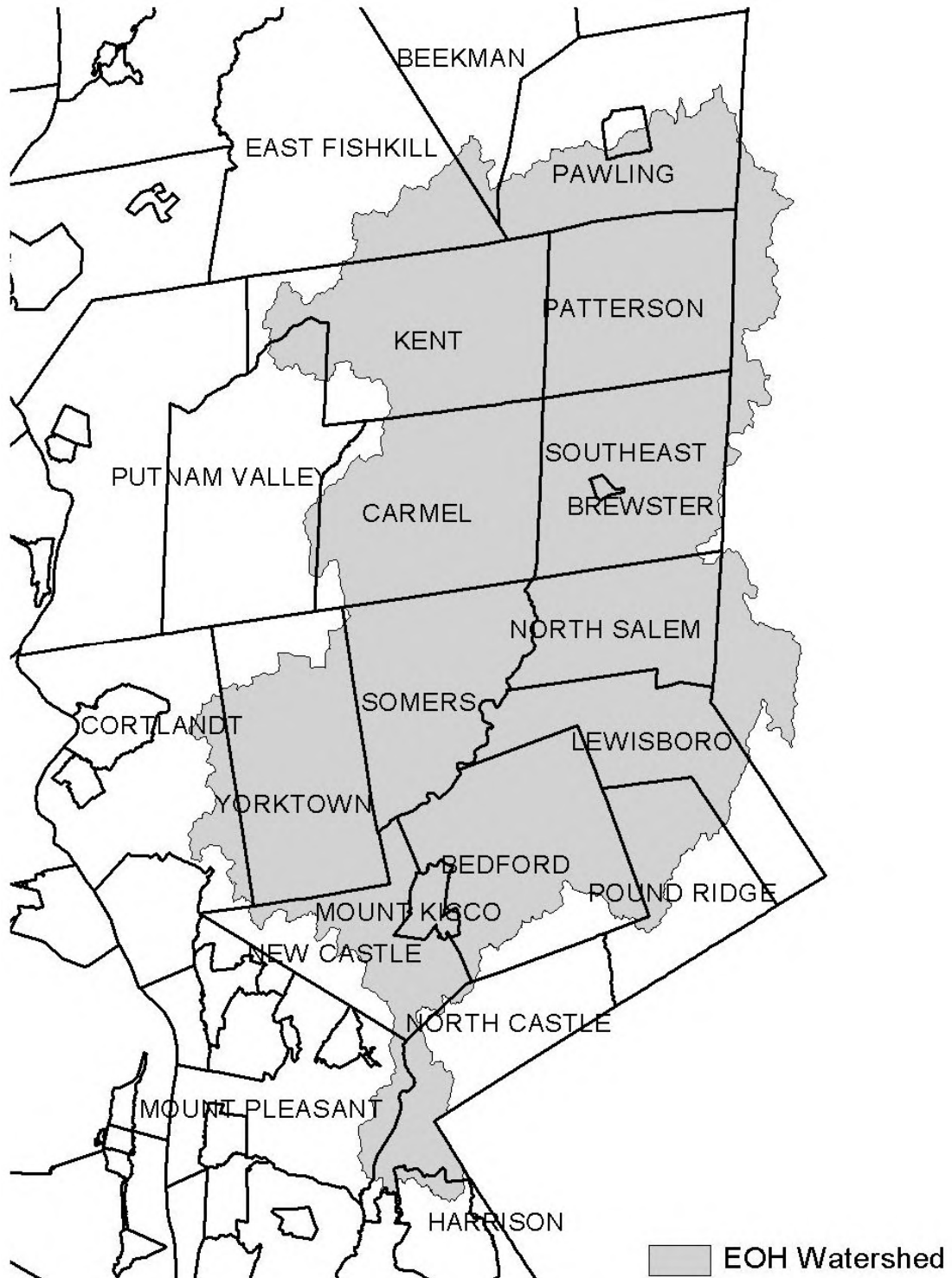

Figure 2 - Onondaga Lake Watershed



Figure 3 - Greenwood Lake Watershed

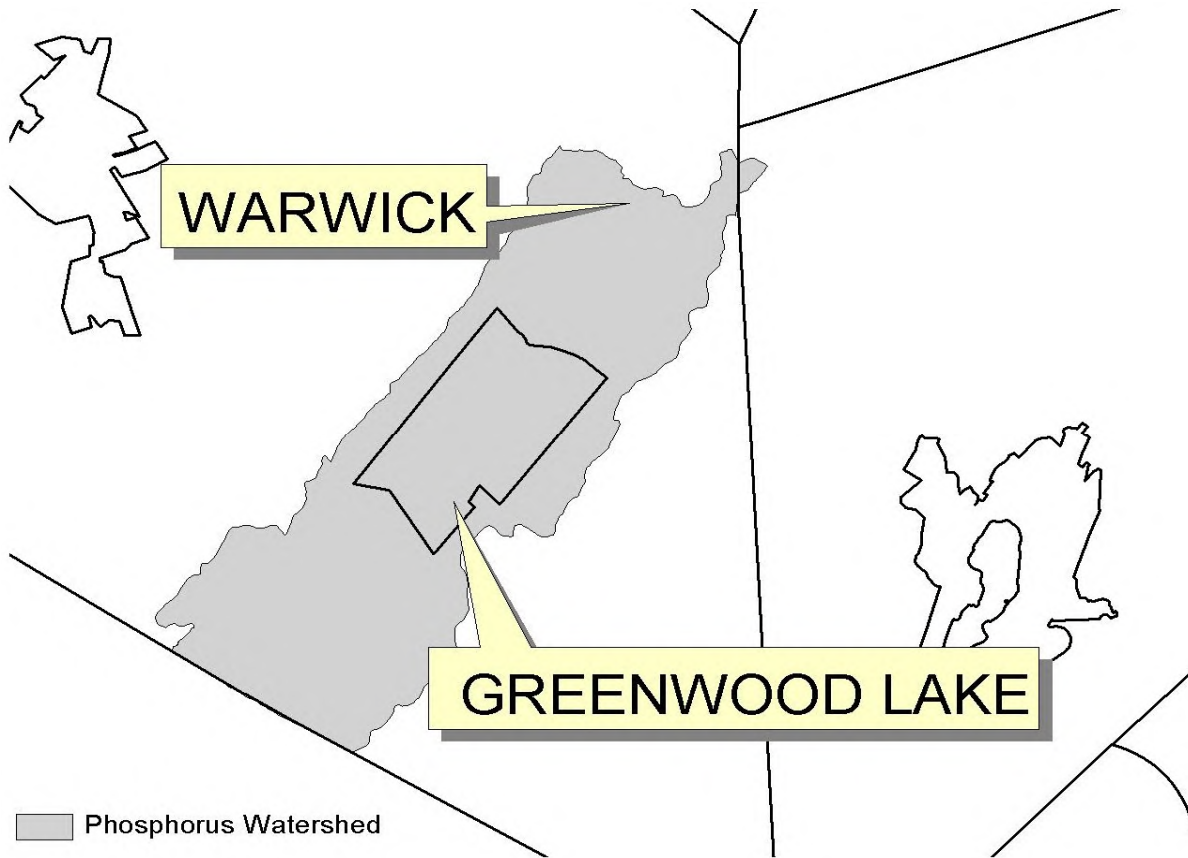

Figure 4 - Oscawana Lake Watershed

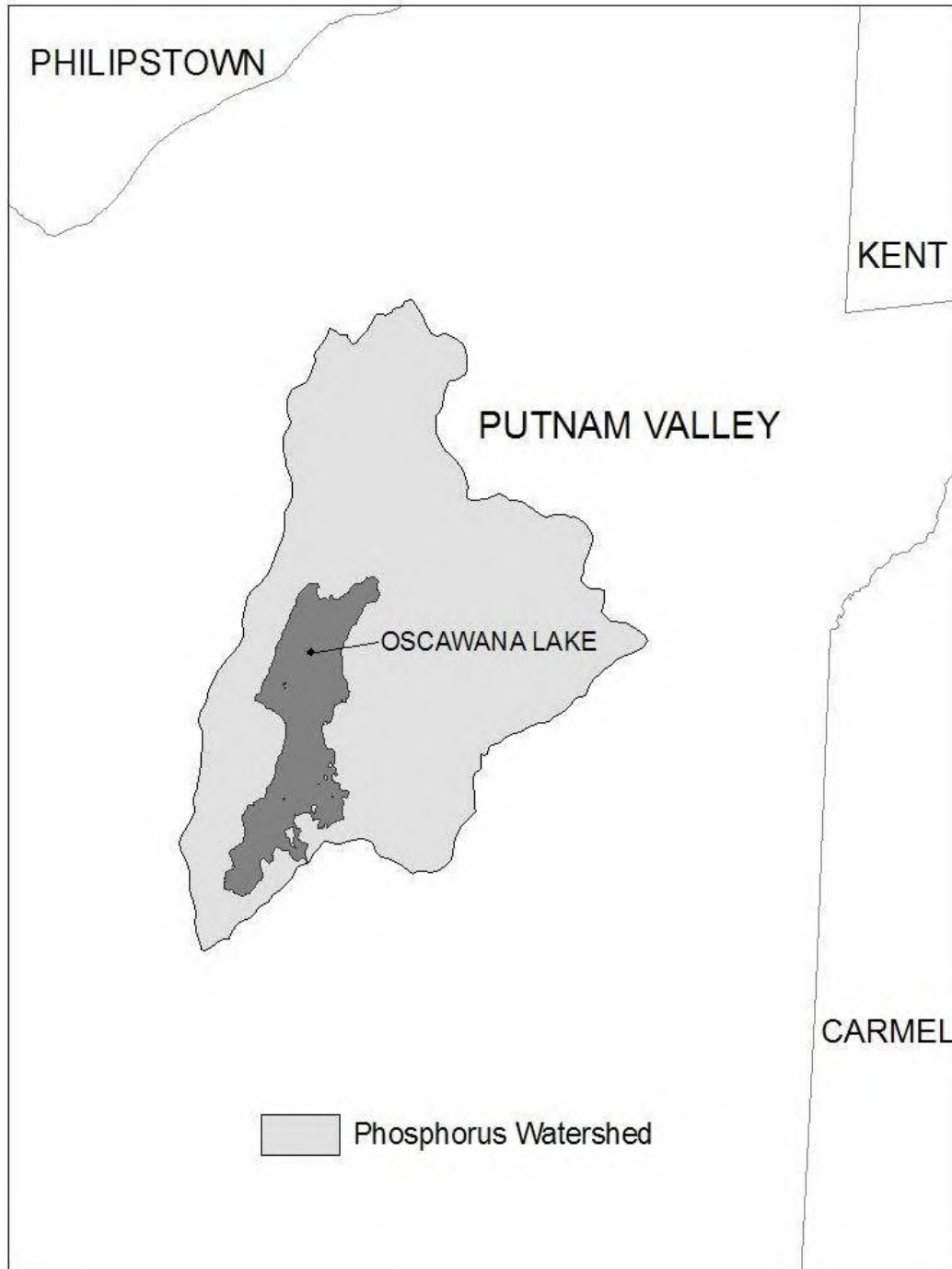
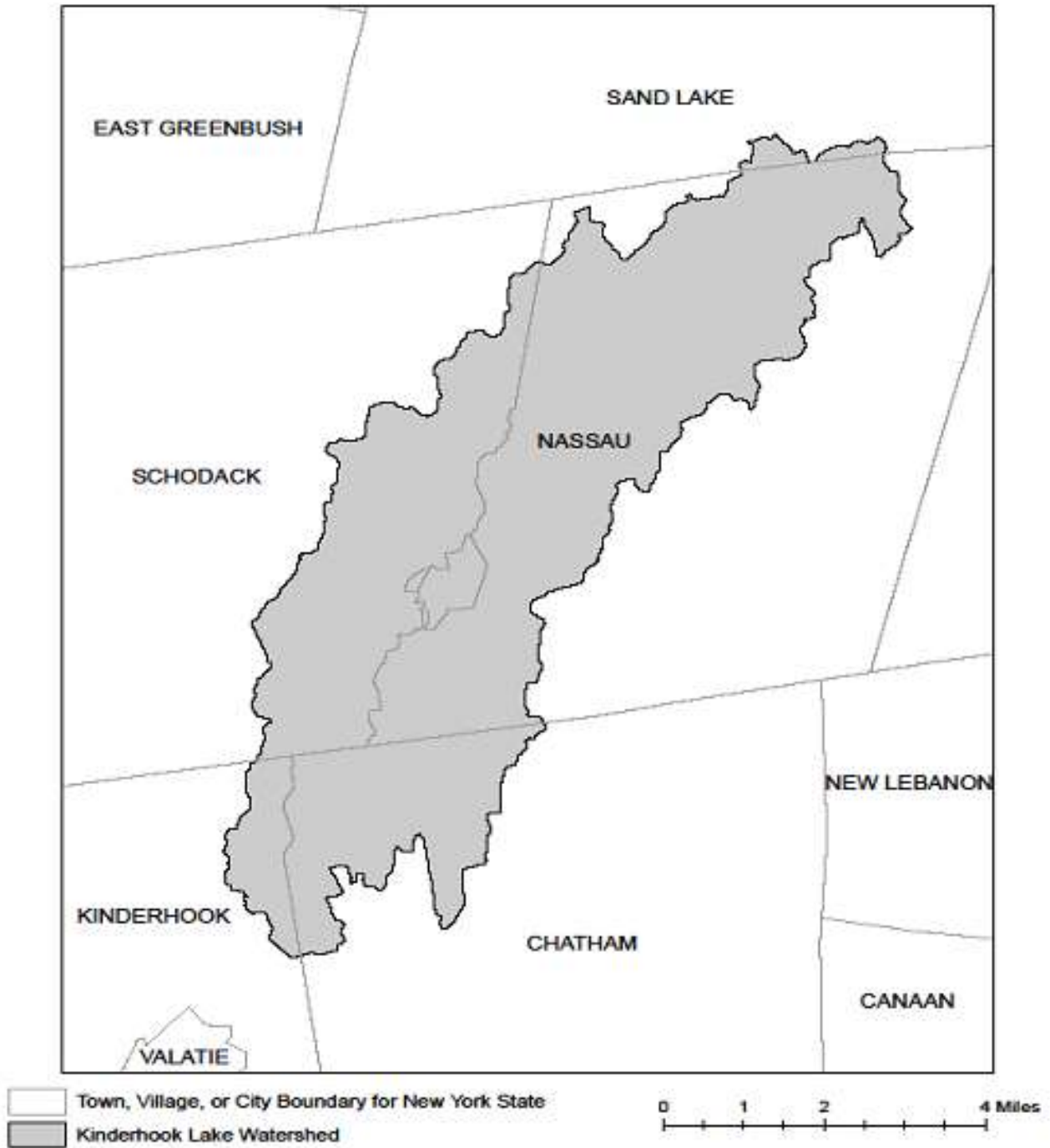

Figure 5 - Kinderhook Lake Watershed



APPENDIX D – Watersheds with Lower Disturbance Threshold

Watersheds where *owners or operators* of construction activities that involve soil disturbances between five thousand (5000) square feet and one (1) acre of land must obtain coverage under this permit.

Entire New York City Watershed that is located east of the Hudson River - See Figure 1 in Appendix C

APPENDIX E – 303(d) Segments Impaired by Construction Related Pollutant(s)

List of 303(d) segments impaired by pollutants related to *construction activity* (e.g. silt, sediment or nutrients). The list was developed using "The Final New York State 2016 Section 303(d) List of Impaired Waters Requiring a TMDL/Other Strategy" dated November 2016. *Owners or operators* of single family home and single family residential subdivisions with 25% or less total impervious cover at total site build-out that involve soil disturbances of one or more acres of land, but less than 5 acres, and *directly discharge* to one of the listed segments below shall prepare a SWPPP that includes post-construction stormwater management practices designed in conformance with the New York State Stormwater Management Design Manual ("Design Manual"), dated January 2015.

COUNTY	WATERBODY	POLLUTANT
Albany	Ann Lee (Shakers) Pond, Stump Pond	Nutrients
Albany	Basic Creek Reservoir	Nutrients
Allegany	Amity Lake, Saunders Pond	Nutrients
Bronx	Long Island Sound, Bronx	Nutrients
Bronx	Van Cortlandt Lake	Nutrients
Broome	Fly Pond, Deer Lake, Sky Lake	Nutrients
Broome	Minor Tribs to Lower Susquehanna (north)	Nutrients
Broome	Whitney Point Lake/Reservoir	Nutrients
Cattaraugus	Allegheny River/Reservoir	Nutrients
Cattaraugus	Beaver (Alma) Lake	Nutrients
Cattaraugus	Case Lake	Nutrients
Cattaraugus	Linlyco/Club Pond	Nutrients
Cayuga	Duck Lake	Nutrients
Cayuga	Little Sodus Bay	Nutrients
Chautauqua	Bear Lake	Nutrients
Chautauqua	Chadakoin River and tribs	Nutrients
Chautauqua	Chautauqua Lake, North	Nutrients
Chautauqua	Chautauqua Lake, South	Nutrients
Chautauqua	Findley Lake	Nutrients
Chautauqua	Hulburt/Clymer Pond	Nutrients
Clinton	Great Chazy River, Lower, Main Stem	Silt/Sediment
Clinton	Lake Champlain, Main Lake, Middle	Nutrients
Clinton	Lake Champlain, Main Lake, North	Nutrients
Columbia	Kinderhook Lake	Nutrients
Columbia	Robinson Pond	Nutrients
Cortland	Dean Pond	Nutrients

303(d) Segments Impaired by Construction Related Pollutant(s)

Dutchess	Fall Kill and tribs	Nutrients
Dutchess	Hillside Lake	Nutrients
Dutchess	Wappingers Lake	Nutrients
Dutchess	Wappingers Lake	Silt/Sediment
Erie	Beeman Creek and tribs	Nutrients
Erie	Ellicott Creek, Lower, and tribs	Silt/Sediment
Erie	Ellicott Creek, Lower, and tribs	Nutrients
Erie	Green Lake	Nutrients
Erie	Little Sister Creek, Lower, and tribs	Nutrients
Erie	Murder Creek, Lower, and tribs	Nutrients
Erie	Rush Creek and tribs	Nutrients
Erie	Scajaquada Creek, Lower, and tribs	Nutrients
Erie	Scajaquada Creek, Middle, and tribs	Nutrients
Erie	Scajaquada Creek, Upper, and tribs	Nutrients
Erie	South Branch Smoke Cr, Lower, and tribs	Silt/Sediment
Erie	South Branch Smoke Cr, Lower, and tribs	Nutrients
Essex	Lake Champlain, Main Lake, South	Nutrients
Essex	Lake Champlain, South Lake	Nutrients
Essex	Willsboro Bay	Nutrients
Genesee	Bigelow Creek and tribs	Nutrients
Genesee	Black Creek, Middle, and minor tribs	Nutrients
Genesee	Black Creek, Upper, and minor tribs	Nutrients
Genesee	Bowen Brook and tribs	Nutrients
Genesee	LeRoy Reservoir	Nutrients
Genesee	Oak Orchard Cr, Upper, and tribs	Nutrients
Genesee	Tonawanda Creek, Middle, Main Stem	Nutrients
Greene	Schoharie Reservoir	Silt/Sediment
Greene	Sleepy Hollow Lake	Silt/Sediment
Herkimer	Steele Creek tribs	Silt/Sediment
Herkimer	Steele Creek tribs	Nutrients
Jefferson	Moon Lake	Nutrients
Kings	Hendrix Creek	Nutrients
Kings	Prospect Park Lake	Nutrients
Lewis	Mill Creek/South Branch, and tribs	Nutrients
Livingston	Christie Creek and tribs	Nutrients
Livingston	Conesus Lake	Nutrients
Livingston	Mill Creek and minor tribs	Silt/Sediment
Monroe	Black Creek, Lower, and minor tribs	Nutrients
Monroe	Buck Pond	Nutrients
Monroe	Cranberry Pond	Nutrients

303(d) Segments Impaired by Construction Related Pollutant(s)

Monroe	Lake Ontario Shoreline, Western	Nutrients
Monroe	Long Pond	Nutrients
Monroe	Mill Creek and tribs	Nutrients
Monroe	Mill Creek/Blue Pond Outlet and tribs	Nutrients
Monroe	Minor Tribs to Irondequoit Bay	Nutrients
Monroe	Rochester Embayment - East	Nutrients
Monroe	Rochester Embayment - West	Nutrients
Monroe	Shipbuilders Creek and tribs	Nutrients
Monroe	Thomas Creek/White Brook and tribs	Nutrients
Nassau	Beaver Lake	Nutrients
Nassau	Camaans Pond	Nutrients
Nassau	East Meadow Brook, Upper, and tribs	Silt/Sediment
Nassau	East Rockaway Channel	Nutrients
Nassau	Grant Park Pond	Nutrients
Nassau	Hempstead Bay	Nutrients
Nassau	Hempstead Lake	Nutrients
Nassau	Hewlett Bay	Nutrients
Nassau	Hog Island Channel	Nutrients
Nassau	Long Island Sound, Nassau County Waters	Nutrients
Nassau	Massapequa Creek and tribs	Nutrients
Nassau	Milburn/Parsonage Creeks, Upp, and tribs	Nutrients
Nassau	Reynolds Channel, west	Nutrients
Nassau	Tidal Tribs to Hempstead Bay	Nutrients
Nassau	Tribs (fresh) to East Bay	Nutrients
Nassau	Tribs (fresh) to East Bay	Silt/Sediment
Nassau	Tribs to Smith/Halls Ponds	Nutrients
Nassau	Woodmere Channel	Nutrients
New York	Harlem Meer	Nutrients
New York	The Lake in Central Park	Nutrients
Niagara	Bergholtz Creek and tribs	Nutrients
Niagara	Hyde Park Lake	Nutrients
Niagara	Lake Ontario Shoreline, Western	Nutrients
Niagara	Lake Ontario Shoreline, Western	Nutrients
Oneida	Ballou, Nail Creeks and tribs	Nutrients
Onondaga	Harbor Brook, Lower, and tribs	Nutrients
Onondaga	Ley Creek and tribs	Nutrients
Onondaga	Minor Tribs to Onondaga Lake	Nutrients
Onondaga	Ninemile Creek, Lower, and tribs	Nutrients
Onondaga	Onondaga Creek, Lower, and tribs	Nutrients
Onondaga	Onondaga Creek, Middle, and tribs	Nutrients

303(d) Segments Impaired by Construction Related Pollutant(s)

Onondaga	Onondaga Lake, northern end	Nutrients
Onondaga	Onondaga Lake, southern end	Nutrients
Ontario	Great Brook and minor tribs	Silt/Sediment
Ontario	Great Brook and minor tribs	Nutrients
Ontario	Hemlock Lake Outlet and minor tribs	Nutrients
Ontario	Honeoye Lake	Nutrients
Orange	Greenwood Lake	Nutrients
Orange	Monhagen Brook and tribs	Nutrients
Orange	Orange Lake	Nutrients
Orleans	Lake Ontario Shoreline, Western	Nutrients
Orleans	Lake Ontario Shoreline, Western	Nutrients
Oswego	Lake Neatahwanta	Nutrients
Oswego	Pleasant Lake	Nutrients
Putnam	Bog Brook Reservoir	Nutrients
Putnam	Boyd Corners Reservoir	Nutrients
Putnam	Croton Falls Reservoir	Nutrients
Putnam	Diverting Reservoir	Nutrients
Putnam	East Branch Reservoir	Nutrients
Putnam	Lake Carmel	Nutrients
Putnam	Middle Branch Reservoir	Nutrients
Putnam	Oscawana Lake	Nutrients
Putnam	Palmer Lake	Nutrients
Putnam	West Branch Reservoir	Nutrients
Queens	Bergen Basin	Nutrients
Queens	Flushing Creek/Bay	Nutrients
Queens	Jamaica Bay, Eastern, and tribs (Queens)	Nutrients
Queens	Kissena Lake	Nutrients
Queens	Meadow Lake	Nutrients
Queens	Willow Lake	Nutrients
Rensselaer	Nassau Lake	Nutrients
Rensselaer	Snyders Lake	Nutrients
Richmond	Grasmere Lake/Bradys Pond	Nutrients
Rockland	Congers Lake, Swartout Lake	Nutrients
Rockland	Rockland Lake	Nutrients
Saratoga	Ballston Lake	Nutrients
Saratoga	Dwaas Kill and tribs	Silt/Sediment
Saratoga	Dwaas Kill and tribs	Nutrients
Saratoga	Lake Lonely	Nutrients
Saratoga	Round Lake	Nutrients
Saratoga	Tribs to Lake Lonely	Nutrients

303(d) Segments Impaired by Construction Related Pollutant(s)

Schenectady	Collins Lake	Nutrients
Schenectady	Duane Lake	Nutrients
Schenectady	Mariaville Lake	Nutrients
Schoharie	Engleville Pond	Nutrients
Schoharie	Summit Lake	Nutrients
Seneca	Reeder Creek and tribs	Nutrients
St.Lawrence	Black Lake Outlet/Black Lake	Nutrients
St.Lawrence	Fish Creek and minor tribs	Nutrients
Steuben	Smith Pond	Nutrients
Suffolk	Agawam Lake	Nutrients
Suffolk	Big/Little Fresh Ponds	Nutrients
Suffolk	Canaan Lake	Silt/Sediment
Suffolk	Canaan Lake	Nutrients
Suffolk	Flanders Bay, West/Lower Sawmill Creek	Nutrients
Suffolk	Fresh Pond	Nutrients
Suffolk	Great South Bay, East	Nutrients
Suffolk	Great South Bay, Middle	Nutrients
Suffolk	Great South Bay, West	Nutrients
Suffolk	Lake Ronkonkoma	Nutrients
Suffolk	Long Island Sound, Suffolk County, West	Nutrients
Suffolk	Mattituck (Marratooka) Pond	Nutrients
Suffolk	Meetinghouse/Terrys Creeks and tribs	Nutrients
Suffolk	Mill and Seven Ponds	Nutrients
Suffolk	Millers Pond	Nutrients
Suffolk	Moriches Bay, East	Nutrients
Suffolk	Moriches Bay, West	Nutrients
Suffolk	Peconic River, Lower, and tidal tribs	Nutrients
Suffolk	Quantuck Bay	Nutrients
Suffolk	Shinnecock Bay and Inlet	Nutrients
Suffolk	Tidal tribs to West Moriches Bay	Nutrients
Sullivan	Bodine, Montgomery Lakes	Nutrients
Sullivan	Davies Lake	Nutrients
Sullivan	Evens Lake	Nutrients
Sullivan	Pleasure Lake	Nutrients
Tompkins	Cayuga Lake, Southern End	Nutrients
Tompkins	Cayuga Lake, Southern End	Silt/Sediment
Tompkins	Owasco Inlet, Upper, and tribs	Nutrients
Ulster	Ashokan Reservoir	Silt/Sediment
Ulster	Esopus Creek, Upper, and minor tribs	Silt/Sediment
Warren	Hague Brook and tribs	Silt/Sediment

303(d) Segments Impaired by Construction Related Pollutant(s)

Warren	Huddle/Finkle Brooks and tribs	Silt/Sediment
Warren	Indian Brook and tribs	Silt/Sediment
Warren	Lake George	Silt/Sediment
Warren	Tribs to L.George, Village of L George	Silt/Sediment
Washington	Cossayuna Lake	Nutrients
Washington	Lake Champlain, South Bay	Nutrients
Washington	Tribs to L.George, East Shore	Silt/Sediment
Washington	Wood Cr/Champlain Canal and minor tribs	Nutrients
Wayne	Port Bay	Nutrients
Westchester	Amawalk Reservoir	Nutrients
Westchester	Blind Brook, Upper, and tribs	Silt/Sediment
Westchester	Cross River Reservoir	Nutrients
Westchester	Lake Katonah	Nutrients
Westchester	Lake Lincolndale	Nutrients
Westchester	Lake Meahagh	Nutrients
Westchester	Lake Mohegan	Nutrients
Westchester	Lake Shenorock	Nutrients
Westchester	Long Island Sound, Westchester (East)	Nutrients
Westchester	Mamaroneck River, Lower	Silt/Sediment
Westchester	Mamaroneck River, Upper, and minor tribs	Silt/Sediment
Westchester	Muscoot/Upper New Croton Reservoir	Nutrients
Westchester	New Croton Reservoir	Nutrients
Westchester	Peach Lake	Nutrients
Westchester	Reservoir No.1 (Lake Isle)	Nutrients
Westchester	Saw Mill River, Lower, and tribs	Nutrients
Westchester	Saw Mill River, Middle, and tribs	Nutrients
Westchester	Sheldrake River and tribs	Silt/Sediment
Westchester	Sheldrake River and tribs	Nutrients
Westchester	Silver Lake	Nutrients
Westchester	Teatown Lake	Nutrients
Westchester	Titicus Reservoir	Nutrients
Westchester	Truesdale Lake	Nutrients
Westchester	Wallace Pond	Nutrients
Wyoming	Java Lake	Nutrients
Wyoming	Silver Lake	Nutrients

APPENDIX F – List of NYS DEC Regional Offices

<u>Region</u>	<u>COVERING THE FOLLOWING COUNTIES:</u>	<u>DIVISION OF ENVIRONMENTAL PERMITS (DEP) PERMIT ADMINISTRATORS</u>	<u>DIVISION OF WATER (DOW) WATER (SPDES) PROGRAM</u>
1	NASSAU AND SUFFOLK	50 CIRCLE ROAD STONY BROOK, NY 11790 TEL. (631) 444-0365	50 CIRCLE ROAD STONY BROOK, NY 11790-3409 TEL. (631) 444-0405
2	BRONX, KINGS, NEW YORK, QUEENS AND RICHMOND	1 HUNTERS POINT PLAZA, 47-40 21ST ST. LONG ISLAND CITY, NY 11101-5407 TEL. (718) 482-4997	1 HUNTERS POINT PLAZA, 47-40 21ST ST. LONG ISLAND CITY, NY 11101-5407 TEL. (718) 482-4933
3	DUTCHESS, ORANGE, PUTNAM, ROCKLAND, SULLIVAN, ULSTER AND WESTCHESTER	21 SOUTH PUTT CORNERS ROAD NEW PALTZ, NY 12561-1696 TEL. (845) 256-3059	100 HILLSIDE AVENUE, SUITE 1W WHITE PLAINS, NY 10603 TEL. (914) 428 - 2505
4	ALBANY, COLUMBIA, DELAWARE, GREENE, MONTGOMERY, OTSEGO, RENSSELAER, SCHENECTADY AND SCHOHARIE	1150 NORTH WESTCOTT ROAD SCHENECTADY, NY 12306-2014 TEL. (518) 357-2069	1130 NORTH WESTCOTT ROAD SCHENECTADY, NY 12306-2014 TEL. (518) 357-2045
5	CLINTON, ESSEX, FRANKLIN, FULTON, HAMILTON, SARATOGA, WARREN AND WASHINGTON	1115 STATE ROUTE 86, Po Box 296 RAY BROOK, NY 12977-0296 TEL. (518) 897-1234	232 GOLF COURSE ROAD WARRENSBURG, NY 12885-1172 TEL. (518) 623-1200
6	HERKIMER, JEFFERSON, LEWIS, ONEIDA AND ST. LAWRENCE	STATE OFFICE BUILDING 317 WASHINGTON STREET WATERTOWN, NY 13601-3787 TEL. (315) 785-2245	STATE OFFICE BUILDING 207 GENESEE STREET UTICA, NY 13501-2885 TEL. (315) 793-2554
7	BROOME, CAYUGA, CHENANGO, CORTLAND, MADISON, ONONDAGA, OSWEGO, TIOGA AND TOMPKINS	615 ERIE BLVD. WEST SYRACUSE, NY 13204-2400 TEL. (315) 426-7438	615 ERIE BLVD. WEST SYRACUSE, NY 13204-2400 TEL. (315) 426-7500
8	CHEMUNG, GENESEE, LIVINGSTON, MONROE, ONTARIO, ORLEANS, SCHUYLER, SENECA, STEBEN, WAYNE AND YATES	6274 EAST AVON-LIMA ROADAVON, NY 14414-9519 TEL. (585) 226-2466	6274 EAST AVON-LIMA RD. AVON, NY 14414-9519 TEL. (585) 226-2466
9	ALLEGANY, CATTARAUGUS, CHAUTAUQUA, ERIE, NIAGARA AND WYOMING	270 MICHIGAN AVENUE BUFFALO, NY 14203-2999 TEL. (716) 851-7165	270 MICHIGAN AVENUE BUFFALO, NY 14203-2999 TEL. (716) 851-7070

Leatherleaf Solar, LLC
7501 Ivison Road
Town of Byron, New York

Appendix B: NYSDEC SPDES General Permit Forms

NOTICE OF INTENT

New York State Department of Environmental Conservation

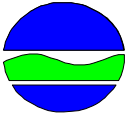

Division of Water

625 Broadway, 4th Floor

Albany, New York 12233-3505

NYR
(for DEC use only)

Stormwater Discharges Associated with Construction Activity Under State Pollutant Discharge Elimination System (SPDES) General Permit # GP-0-20-001

All sections must be completed unless otherwise noted. Failure to complete all items may result in this form being returned to you, thereby delaying your coverage under this General Permit. Applicants must read and understand the conditions of the permit and prepare a Stormwater Pollution Prevention Plan prior to submitting this NOI. Applicants are responsible for identifying and obtaining other DEC permits that may be required.

-IMPORTANT-
RETURN THIS FORM TO THE ADDRESS ABOVE
OWNER/OPERATOR MUST SIGN FORM

Owner/Operator Information

Owner/Operator (Company Name/Private Owner Name/Municipality Name)

L E A T H E R L E A F S O L A R , L L C

Owner/Operator Contact Person Last Name (NOT CONSULTANT)

H A W V E R M A L E

Owner/Operator Contact Person First Name

N I C K

Owner/Operator Mailing Address

P . O . B O X 1 7 3

City

L A T H A M

State

N Y

Zip

1 2 1 1 0 -

Phone (Owner/Operator)

2 0 3 - 5 5 8 - 5 6 0 2

Fax (Owner/Operator)

- - -

Email (Owner/Operator)

N I C K . H A W V E R M A L E @ C C R E N E W . C O M

FED TAX ID

- (not required for individuals)

Project Site Information

Project/Site Name

L E A T H E R L E A F S O L A R , L L C

Street Address (NOT P.O. BOX)

I V I S O N R O A D

Side of Street

 North South East West

City/Town/Village (THAT ISSUES BUILDING PERMIT)

B Y R O N

State Zip

N Y

1 4 4 2 2 -

County

G E N E S E E

DEC Region

8

Name of Nearest Cross Street

F R E E M A N R O A D

Distance to Nearest Cross Street (Feet)

0

Project In Relation to Cross Street

 North South East WestTax Map Numbers
Section-Block-Parcel

9 . - 1 - 7 . 1 1 3

Tax Map Numbers

1. Provide the Geographic Coordinates for the project site in NYTM Units. To do this you **must** go to the NYSDEC Stormwater Interactive Map on the DEC website at:

www.dec.ny.gov/imsmaps/stormwater/viewer.htm

Zoom into your Project Location such that you can accurately click on the centroid of your site. Once you have located your project site, go to the tool boxes on the top and choose "i"(identify). Then click on the center of your site and a new window containing the X, Y coordinates in UTM will pop up. Transcribe these coordinates into the boxes below. For problems with the interactive map use the help function.

X Coordinates (Easting)

2 5 2 5 1 3

Y Coordinates (Northing)

4 7 7 1 0 7 0

2. What is the nature of this construction project?

- New Construction
- Redevelopment with increase in impervious area
- Redevelopment with no increase in impervious area

3. Select the predominant land use for both pre and post development conditions.
SELECT ONLY ONE CHOICE FOR EACH

**Pre-Development
Existing Land Use**

- FOREST
- PASTURE/OPEN LAND
- CULTIVATED LAND
- SINGLE FAMILY HOME
- SINGLE FAMILY SUBDIVISION
- TOWN HOME RESIDENTIAL
- MULTIFAMILY RESIDENTIAL
- INSTITUTIONAL/SCHOOL
- INDUSTRIAL
- COMMERCIAL
- ROAD/HIGHWAY
- RECREATIONAL/SPORTS FIELD
- BIKE PATH/TRAIL
- LINEAR UTILITY
- PARKING LOT
- OTHER

--	--	--	--	--	--	--	--	--	--	--	--	--	--	--	--	--	--	--	--	--

**Post-Development
Future Land Use**

- SINGLE FAMILY HOME
- SINGLE FAMILY SUBDIVISION
- TOWN HOME RESIDENTIAL
- MULTIFAMILY RESIDENTIAL
- INSTITUTIONAL/SCHOOL
- INDUSTRIAL
- COMMERCIAL
- MUNICIPAL
- ROAD/HIGHWAY
- RECREATIONAL/SPORTS FIELD
- BIKE PATH/TRAIL
- LINEAR UTILITY (water, sewer, gas, etc.)
- PARKING LOT
- CLEARING/GRADING ONLY
- DEMOLITION, NO REDEVELOPMENT
- WELL DRILLING ACTIVITY *(Oil, Gas, etc.)
- OTHER

Number of Lots

--	--	--

S	O	L	A	R		F	A	R	M					
---	---	---	---	---	--	---	---	---	---	--	--	--	--	--

***Note:** for gas well drilling, non-high volume hydraulic fractured wells only

4. In accordance with the larger common plan of development or sale, enter the total project site area; the total area to be disturbed; existing impervious area to be disturbed (for redevelopment activities); and the future impervious area constructed within the disturbed area. (Round to the nearest tenth of an acre.)

Total Site Area	Total Area To Be Disturbed	Existing Impervious Area To Be Disturbed	Future Impervious Area Within Disturbed Area																								
<table border="1" style="display: inline-table; width: 60px; height: 25px;"> <tr> <td></td><td>1</td><td>7</td><td>9</td><td>.</td><td>9</td> </tr> </table>		1	7	9	.	9	<table border="1" style="display: inline-table; width: 60px; height: 25px;"> <tr> <td></td><td></td><td>3</td><td>5</td><td>.</td><td>0</td> </tr> </table>			3	5	.	0	<table border="1" style="display: inline-table; width: 60px; height: 25px;"> <tr> <td></td><td></td><td></td><td>0</td><td>.</td><td>0</td> </tr> </table>				0	.	0	<table border="1" style="display: inline-table; width: 60px; height: 25px;"> <tr> <td></td><td></td><td></td><td>0</td><td>.</td><td>0</td> </tr> </table>				0	.	0
	1	7	9	.	9																						
		3	5	.	0																						
			0	.	0																						
			0	.	0																						

5. Do you plan to disturb more than 5 acres of soil at any one time? Yes No

6. Indicate the percentage of each Hydrologic Soil Group(HSG) at the site.

A	B	C	D												
<table border="1" style="display: inline-table; width: 40px; height: 25px;"><tr><td></td><td></td><td>4</td></tr></table> %			4	<table border="1" style="display: inline-table; width: 40px; height: 25px;"><tr><td></td><td>3</td><td>4</td></tr></table> %		3	4	<table border="1" style="display: inline-table; width: 40px; height: 25px;"><tr><td></td><td></td><td>0</td></tr></table> %			0	<table border="1" style="display: inline-table; width: 40px; height: 25px;"><tr><td></td><td>6</td><td>2</td></tr></table> %		6	2
		4													
	3	4													
		0													
	6	2													

7. Is this a phased project? Yes No

8. Enter the planned start and end dates of the disturbance activities.

Start Date	-	End Date																				
<table border="1" style="display: inline-table; width: 60px; height: 25px;"> <tr> <td>0</td><td>9</td><td>/</td><td>0</td><td>1</td><td>/</td><td>2</td><td>0</td><td>2</td><td>3</td> </tr> </table>	0	9	/	0	1	/	2	0	2	3	-	<table border="1" style="display: inline-table; width: 60px; height: 25px;"> <tr> <td>0</td><td>9</td><td>/</td><td>0</td><td>1</td><td>/</td><td>2</td><td>0</td><td>2</td><td>4</td> </tr> </table>	0	9	/	0	1	/	2	0	2	4
0	9	/	0	1	/	2	0	2	3													
0	9	/	0	1	/	2	0	2	4													

15. Does the site runoff enter a separate storm sewer system (including roadside drains, swales, ditches, culverts, etc)? Yes No Unknown

16. What is the name of the municipality/entity that owns the separate storm sewer system?

N	/	A																													

17. Does any runoff from the site enter a sewer classified as a Combined Sewer? Yes No Unknown

18. Will future use of this site be an agricultural property as defined by the NYS Agriculture and Markets Law? Yes No

19. Is this property owned by a state authority, state agency, federal government or local government? Yes No

20. Is this a remediation project being done under a Department approved work plan? (i.e. CERCLA, RCRA, Voluntary Cleanup Agreement, etc.) Yes No

21. Has the required Erosion and Sediment Control component of the SWPPP been developed in conformance with the current NYS Standards and Specifications for Erosion and Sediment Control (aka Blue Book)? Yes No

22. Does this construction activity require the development of a SWPPP that includes the post-construction stormwater management practice component (i.e. Runoff Reduction, Water Quality and Quantity Control practices/techniques)? Yes No

If No, skip questions 23 and 27-39.

23. Has the post-construction stormwater management practice component of the SWPPP been developed in conformance with the current NYS Stormwater Management Design Manual? Yes No

24. The Stormwater Pollution Prevention Plan (SWPPP) was prepared by:

- Professional Engineer (P.E.)
- Soil and Water Conservation District (SWCD)
- Registered Landscape Architect (R.L.A)
- Certified Professional in Erosion and Sediment Control (CPESC)
- Owner/Operator
- Other

--	--	--	--	--	--	--	--	--	--	--	--	--	--	--	--	--	--	--	--

SWPPP Preparer

L	A	N	G	A	N	E	N	G	I	N	E	E	R	I	N	G																	
---	---	---	---	---	---	---	---	---	---	---	---	---	---	---	---	---	--	--	--	--	--	--	--	--	--	--	--	--	--	--	--	--	--

Contact Name (Last, Space, First)

Z	O	L	E	Z	I	,	C	H	R	I	S	T	I	N	A																	
---	---	---	---	---	---	---	---	---	---	---	---	---	---	---	---	--	--	--	--	--	--	--	--	--	--	--	--	--	--	--	--	--

Mailing Address

1	N	O	R	T	H	B	R	O	A	D	W	A	Y	,	S	U	I	T	E	9	1	0											
---	---	---	---	---	---	---	---	---	---	---	---	---	---	---	---	---	---	---	---	---	---	---	--	--	--	--	--	--	--	--	--	--	--

City

W	H	I	T	E	P	L	A	I	N	S																			
---	---	---	---	---	---	---	---	---	---	---	--	--	--	--	--	--	--	--	--	--	--	--	--	--	--	--	--	--	--

State Zip

N	Y	1	0	6	0	1	-			
---	---	---	---	---	---	---	---	--	--	--

Phone

9	1	4	-	3	2	3	-	7	4	1	8
---	---	---	---	---	---	---	---	---	---	---	---

Fax

			-				-			
--	--	--	---	--	--	--	---	--	--	--

Email

C	Z	O	L	E	Z	I	@	L	A	N	G	A	N	.	C	O	M																
---	---	---	---	---	---	---	---	---	---	---	---	---	---	---	---	---	---	--	--	--	--	--	--	--	--	--	--	--	--	--	--	--	--

--	--	--	--	--	--	--	--	--	--	--	--	--	--	--	--	--	--

SWPPP Preparer Certification

I hereby certify that the Stormwater Pollution Prevention Plan (SWPPP) for this project has been prepared in accordance with the terms and conditions of the GP-0-20-001. Furthermore, I understand that certifying false, incorrect or inaccurate information is a violation of this permit and the laws of the State of New York and could subject me to criminal, civil and/or administrative proceedings.

First Name

M	I	C	H	A	E	L											
---	---	---	---	---	---	---	--	--	--	--	--	--	--	--	--	--	--

MI

--

Last Name

F	I	N	A	N											
---	---	---	---	---	--	--	--	--	--	--	--	--	--	--	--

Signature

--

Date

		/			/			
--	--	---	--	--	---	--	--	--

Post-construction Stormwater Management Practice (SMP) Requirements

Important: Completion of Questions 27-39 is not required if response to Question 22 is No.

27. Identify all site planning practices that were used to prepare the final site plan/layout for the project.

- Preservation of Undisturbed Areas
- Preservation of Buffers
- Reduction of Clearing and Grading
- Locating Development in Less Sensitive Areas
- Roadway Reduction
- Sidewalk Reduction
- Driveway Reduction
- Cul-de-sac Reduction
- Building Footprint Reduction
- Parking Reduction

27a. Indicate which of the following soil restoration criteria was used to address the requirements in Section 5.1.6("Soil Restoration") of the Design Manual (2010 version).

- All disturbed areas will be restored in accordance with the Soil Restoration requirements in Table 5.3 of the Design Manual (see page 5-22).
- Compacted areas were considered as impervious cover when calculating the **WQv Required**, and the compacted areas were assigned a post-construction Hydrologic Soil Group (HSG) designation that is one level less permeable than existing conditions for the hydrology analysis.

28. Provide the total Water Quality Volume (WQv) required for this project (based on final site plan/layout).

Total WQv Required

. acre-feet

29. Identify the RR techniques (Area Reduction), RR techniques (Volume Reduction) and Standard SMPs with RRv Capacity in Table 1 (See Page 9) that were used to reduce the Total WQv Required(#28).

Also, provide in Table 1 the total impervious area that contributes runoff to each technique/practice selected. For the Area Reduction Techniques, provide the total contributing area (includes pervious area) and, if applicable, the total impervious area that contributes runoff to the technique/practice.

Note: Redevelopment projects shall use Tables 1 and 2 to identify the SMPs used to treat and/or reduce the WQv required. If runoff reduction techniques will not be used to reduce the required WQv, skip to question 33a after identifying the SMPs.

Table 1 - Runoff Reduction (RR) Techniques and Standard Stormwater Management Practices (SMPs)

<u>RR Techniques (Area Reduction)</u>	<u>Total Contributing Area (acres)</u>		<u>Total Contributing Impervious Area (acres)</u>	
<input type="radio"/> Conservation of Natural Areas (RR-1) ...				
<input checked="" type="radio"/> Sheetflow to Riparian Buffers/Filters Strips (RR-2)	0	6	0	1
<input type="radio"/> Tree Planting/Tree Pit (RR-3)				
<input type="radio"/> Disconnection of Rooftop Runoff (RR-4) ..				
<u>RR Techniques (Volume Reduction)</u>				
<input type="radio"/> Vegetated Swale (RR-5)				
<input type="radio"/> Rain Garden (RR-6)				
<input type="radio"/> Stormwater Planter (RR-7)				
<input type="radio"/> Rain Barrel/Cistern (RR-8)				
<input type="radio"/> Porous Pavement (RR-9)				
<input type="radio"/> Green Roof (RR-10)				
<u>Standard SMPs with RRv Capacity</u>				
<input type="radio"/> Infiltration Trench (I-1)				
<input type="radio"/> Infiltration Basin (I-2)				
<input type="radio"/> Dry Well (I-3)				
<input type="radio"/> Underground Infiltration System (I-4)				
<input type="radio"/> Bioretention (F-5)				
<input type="radio"/> Dry Swale (O-1)				
<u>Standard SMPs</u>				
<input type="radio"/> Micropool Extended Detention (P-1)				
<input type="radio"/> Wet Pond (P-2)				
<input type="radio"/> Wet Extended Detention (P-3)				
<input type="radio"/> Multiple Pond System (P-4)				
<input type="radio"/> Pocket Pond (P-5)				
<input type="radio"/> Surface Sand Filter (F-1)				
<input type="radio"/> Underground Sand Filter (F-2)				
<input type="radio"/> Perimeter Sand Filter (F-3)				
<input type="radio"/> Organic Filter (F-4)				
<input type="radio"/> Shallow Wetland (W-1)				
<input type="radio"/> Extended Detention Wetland (W-2)				
<input type="radio"/> Pond/Wetland System (W-3)				
<input type="radio"/> Pocket Wetland (W-4)				
<input type="radio"/> Wet Swale (O-2)				

Table 2 - Alternative SMPs
(DO NOT INCLUDE PRACTICES BEING
USED FOR PRETREATMENT ONLY)

Alternative SMP	Total Contributing Impervious Area (acres)														
<input type="radio"/> Hydrodynamic	<table border="1"><tr><td></td><td></td><td></td><td></td></tr></table>														
<input type="radio"/> Wet Vault	<table border="1"><tr><td></td><td></td><td></td><td></td></tr></table>														
<input type="radio"/> Media Filter	<table border="1"><tr><td></td><td></td><td></td><td></td></tr></table>														
<input type="radio"/> Other <table border="1" style="display: inline-table; vertical-align: middle;"><tr><td></td><td></td><td></td><td></td><td></td><td></td><td></td><td></td><td></td><td></td></tr></table>											<table border="1"><tr><td></td><td></td><td></td><td></td></tr></table>				

Provide the name and manufacturer of the Alternative SMPs (i.e. proprietary practice(s)) being used for WQv treatment.

Name

--	--	--	--	--	--	--	--	--	--	--	--	--	--	--	--	--	--	--	--	--	--	--

Manufacturer

--	--	--	--	--	--	--	--	--	--	--	--	--	--	--	--	--	--	--	--	--	--	--

Note: Redevelopment projects which do not use RR techniques, shall use questions 28, 29, 33 and 33a to provide SMPs used, total WQv required and total WQv provided for the project.

30. Indicate the Total RRv provided by the RR techniques (Area/Volume Reduction) and Standard SMPs with RRv capacity identified in question 29.

Total RRv provided

			0
--	--	--	---

 .

0	0	1
---	---	---

 acre-feet

31. Is the Total RRv provided (#30) greater than or equal to the total WQv required (#28).

Yes No

If Yes, go to question 36.
If No, go to question 32.

32. Provide the Minimum RRv required based on HSG.
[Minimum RRv Required = (P)(0.95)(Ai)/12, Ai=(S)(Aic)]

Minimum RRv Required

--	--	--

 .

--	--	--

 acre-feet

32a. Is the Total RRv provided (#30) greater than or equal to the Minimum RRv Required (#32)?

Yes No

If Yes, go to question 33.

Note: Use the space provided in question #39 to summarize the specific site limitations and justification for not reducing 100% of WQv required (#28). A detailed evaluation of the specific site limitations and justification for not reducing 100% of the WQv required (#28) must also be included in the SWPPP.

If No, sizing criteria has not been met, so NOI can not be processed. SWPPP preparer must modify design to meet sizing criteria.

33. Identify the Standard SMPs in Table 1 and, if applicable, the Alternative SMPs in Table 2 that were used to treat the remaining total WQv(=Total WQv Required in 28 - Total RRv Provided in 30).

Also, provide in Table 1 and 2 the total impervious area that contributes runoff to each practice selected.

Note: Use Tables 1 and 2 to identify the SMPs used on Redevelopment projects.

33a. Indicate the Total WQv provided (i.e. WQv treated) by the SMPs identified in question #33 and Standard SMPs with RRv Capacity identified in question 29.

WQv Provided
 . **acre-feet**

Note: For the standard SMPs with RRv capacity, the WQv provided by each practice = the WQv calculated using the contributing drainage area to the practice - RRv provided by the practice. (See Table 3.5 in Design Manual)

34. Provide the sum of the Total RRv provided (#30) and the WQv provided (#33a). .

35. Is the sum of the RRv provided (#30) and the WQv provided (#33a) greater than or equal to the total WQv required (#28)? **Yes** **No**

**If Yes, go to question 36.
 If No, sizing criteria has not been met, so NOI can not be processed. SWPPP preparer must modify design to meet sizing criteria.**

36. Provide the total Channel Protection Storage Volume (CPv) required and provided or select waiver (36a), if applicable.

CPv Required . **acre-feet** **CPv Provided** . **acre-feet**

36a. The need to provide channel protection has been waived because:

- Site discharges directly to tidal waters or a fifth order or larger stream.
- Reduction of the total CPv is achieved on site through runoff reduction techniques or infiltration systems.

37. Provide the Overbank Flood (Qp) and Extreme Flood (Qf) control criteria or select waiver (37a), if applicable.

Total Overbank Flood Control Criteria (Qp)

Pre-Development 2 9 . 1 8 **CFS** **Post-development** 2 9 . 1 8 **CFS**

Total Extreme Flood Control Criteria (Qf)

Pre-Development 1 0 3 . 8 9 **CFS** **Post-development** 1 0 3 . 8 9 **CFS**

37a. The need to meet the Qp and Qf criteria has been waived because:

- Site discharges directly to tidal waters or a fifth order or larger stream.
- Downstream analysis reveals that the Qp and Qf controls are not required

38. Has a long term Operation and Maintenance Plan for the post-construction stormwater management practice(s) been developed?

Yes No

If Yes, Identify the entity responsible for the long term Operation and Maintenance

L E A T H E R L E A F S O L A R , L L C

[Empty grid for identifying the entity responsible for the long term Operation and Maintenance]

39. Use this space to summarize the specific site limitations and justification for not reducing 100% of WQv required(#28). (See question 32a) This space can also be used for other pertinent project information.

The solar panels will be constructed on a rack system and there is adequate space between the panels so that rain water can flow off the panel and continue as sheet flow over the surface: however, the project does include construction of inverters that will be installed on top of a concrete pad and the addition of the permeable haul road. A Stormwater Pollution Prevention Plan addressing post-construction stormwater practices has been designed in accordance with the "NYS Stormwater Management Design Manual".

40. Identify other DEC permits, existing and new, that are required for this project/facility.

- Air Pollution Control
- Coastal Erosion
- Hazardous Waste
- Long Island Wells
- Mined Land Reclamation
- Solid Waste
- Navigable Waters Protection / Article 15
- Water Quality Certificate
- Dam Safety
- Water Supply
- Freshwater Wetlands/Article 24
- Tidal Wetlands
- Wild, Scenic and Recreational Rivers
- Stream Bed or Bank Protection / Article 15
- Endangered or Threatened Species (Incidental Take Permit)
- Individual SPDES
- SPDES Multi-Sector GP

N	Y	R						
---	---	---	--	--	--	--	--	--
- Other

--	--	--	--	--	--	--	--	--	--	--	--	--	--	--	--	--	--	--	--
- None

41. Does this project require a US Army Corps of Engineers Wetland Permit? Yes No
If Yes, Indicate Size of Impact.

--	--	--	--	--	--

 .

--

42. Is this project subject to the requirements of a regulated, traditional land use control MS4? Yes No
(If No, skip question 43)

43. Has the "MS4 SWPPP Acceptance" form been signed by the principal executive officer or ranking elected official and submitted along with this NOI? Yes No

44. If this NOI is being submitted for the purpose of continuing or transferring coverage under a general permit for stormwater runoff from construction activities, please indicate the former SPDES number assigned.

N	Y	R						
---	---	---	--	--	--	--	--	--

Owner/Operator Certification

I have read or been advised of the permit conditions and believe that I understand them. I also understand that, under the terms of the permit, there may be reporting requirements. I hereby certify that this document and the corresponding documents were prepared under my direction or supervision. I am aware that there are significant penalties for submitting false information, including the possibility of fine and imprisonment for knowing violations. I further understand that coverage under the general permit will be identified in the acknowledgment that I will receive as a result of submitting this NOI and can be as long as sixty (60) business days as provided for in the general permit. I also understand that, by submitting this NOI, I am acknowledging that the SWPPP has been developed and will be implemented as the first element of construction, and agreeing to comply with all the terms and conditions of the general permit for which this NOI is being submitted.

Print First Name

N	I	C	K																
---	---	---	---	--	--	--	--	--	--	--	--	--	--	--	--	--	--	--	--

MI

--

Print Last Name

H	A	W	V	E	R	M	A	L	E										
---	---	---	---	---	---	---	---	---	---	--	--	--	--	--	--	--	--	--	--

Owner/Operator Signature

--	--	--	--	--	--	--	--	--	--	--	--	--	--	--	--	--	--	--	--

Date

		/			/				
--	--	---	--	--	---	--	--	--	--



SWPPP Preparer Certification Form

*SPDES General Permit for Stormwater
Discharges From Construction Activity
(GP-0-20-001)*

Project Site Information

Project/Site Name

Leatherleaf Solar, LLC

Owner/Operator Information

Owner/Operator (Company Name/Private Owner/Municipality Name)

Langan

Certification Statement – SWPPP Preparer

I hereby certify that the Stormwater Pollution Prevention Plan (SWPPP) for this project has been prepared in accordance with the terms and conditions of the GP-0-20-001. Furthermore, I understand that certifying false, incorrect or inaccurate information is a violation of this permit and the laws of the State of New York and could subject me to criminal, civil and/or administrative proceedings.

Michael

First name

MI

Finan

Last Name

Signature

Date



Owner/Operator Certification Form

SPDES General Permit For Stormwater Discharges From Construction Activity (GP-0-20-001)

Project/Site Name: Leatherleaf Solar, LLC

eNOI Submission Number: _____

eNOI Submitted by: Owner/Operator SWPPP Preparer Other

Certification Statement - Owner/Operator

I have read or been advised of the permit conditions and believe that I understand them. I also understand that, under the terms of the permit, there may be reporting requirements. I hereby certify that this document and the corresponding documents were prepared under my direction or supervision. I am aware that there are significant penalties for submitting false information, including the possibility of fine and imprisonment for knowing violations. I further understand that coverage under the general permit will be identified in the acknowledgment that I will receive as a result of submitting this NOI and can be as long as sixty (60) business days as provided for in the general permit. I also understand that, by submitting this NOI, I am acknowledging that the SWPPP has been developed and will be implemented as the first element of construction, and agreeing to comply with all the terms and conditions of the general permit for which this NOI is being submitted.

Owner/Operator First Name

M.I. Last Name

Signature

Date

**New York State Department of Environmental Conservation
Division of Water
625 Broadway, 4th Floor
Albany, New York 12233-3505**

(NOTE: Submit completed form to address above)

**NOTICE OF TERMINATION for Storm Water Discharges Authorized
under the SPDES General Permit for Construction Activity**

Please indicate your permit identification number: NYR _____

I. Owner or Operator Information

1. Owner/Operator Name:

2. Street Address:

3. City/State/Zip:

4. Contact Person:

4a. Telephone:

4b. Contact Person E-Mail:

II. Project Site Information

5. Project/Site Name:

6. Street Address:

7. City/Zip:

8. County:

III. Reason for Termination

9a. All disturbed areas have achieved final stabilization in accordance with the general permit and SWPPP. *Date final stabilization completed (month/year): _____

9b. Permit coverage has been transferred to new owner/operator. Indicate new owner/operator's permit identification number: NYR _____
(Note: Permit coverage can not be terminated by owner identified in I.1. above until new owner/operator obtains coverage under the general permit)

9c. Other (Explain on Page 2)

IV. Final Site Information:

10a. Did this construction activity require the development of a SWPPP that includes post-construction stormwater management practices? yes no (If no, go to question 10f.)

10b. Have all post-construction stormwater management practices included in the final SWPPP been constructed? yes no (If no, explain on Page 2)

10c. Identify the entity responsible for long-term operation and maintenance of practice(s)?

**NOTICE OF TERMINATION for Storm Water Discharges Authorized under the
SPDES General Permit for Construction Activity - continued**

10d. Has the entity responsible for long-term operation and maintenance been given a copy of the operation and maintenance plan required by the general permit? yes no

10e. Indicate the method used to ensure long-term operation and maintenance of the post-construction stormwater management practice(s):

- Post-construction stormwater management practice(s) and any right-of-way(s) needed to maintain practice(s) have been deeded to the municipality.
- Executed maintenance agreement is in place with the municipality that will maintain the post-construction stormwater management practice(s).
- For post-construction stormwater management practices that are privately owned, a mechanism is in place that requires operation and maintenance of the practice(s) in accordance with the operation and maintenance plan, such as a deed covenant in the owner or operator's deed of record.
- For post-construction stormwater management practices that are owned by a public or private institution (e.g. school, university or hospital), government agency or authority, or public utility; policy and procedures are in place that ensures operation and maintenance of the practice(s) in accordance with the operation and maintenance plan.

10f. Provide the total area of impervious surface (i.e. roof, pavement, concrete, gravel, etc.) constructed within the disturbance area? _____
(acres)

11. Is this project subject to the requirements of a regulated, traditional land use control MS4? yes
 no
(If Yes, complete section VI - "MS4 Acceptance" statement

V. Additional Information/Explanation:
(Use this section to answer questions 9c. and 10b., if applicable)

VI. MS4 Acceptance - MS4 Official (principal executive officer or ranking elected official) or Duly Authorized Representative (Note: Not required when 9b. is checked -transfer of coverage)

I have determined that it is acceptable for the owner or operator of the construction project identified in question 5 to submit the Notice of Termination at this time.

Printed Name:

Title/Position:

Signature:

Date:

**NOTICE OF TERMINATION for Storm Water Discharges Authorized under the
SPDES General Permit for Construction Activity - continued**

VII. Qualified Inspector Certification - Final Stabilization:

I hereby certify that all disturbed areas have achieved final stabilization as defined in the current version of the general permit, and that all temporary, structural erosion and sediment control measures have been removed. Furthermore, I understand that certifying false, incorrect or inaccurate information is a violation of the referenced permit and the laws of the State of New York and could subject me to criminal, civil and/or administrative proceedings.

Printed Name:

Title/Position:

Signature:

Date:

VIII. Qualified Inspector Certification - Post-construction Stormwater Management Practice(s):

I hereby certify that all post-construction stormwater management practices have been constructed in conformance with the SWPPP. Furthermore, I understand that certifying false, incorrect or inaccurate information is a violation of the referenced permit and the laws of the State of New York and could subject me to criminal, civil and/or administrative proceedings.

Printed Name:

Title/Position:

Signature:

Date:

IX. Owner or Operator Certification

I hereby certify that this document was prepared by me or under my direction or supervision. My determination, based upon my inquiry of the person(s) who managed the construction activity, or those persons directly responsible for gathering the information, is that the information provided in this document is true, accurate and complete. Furthermore, I understand that certifying false, incorrect or inaccurate information is a violation of the referenced permit and the laws of the State of New York and could subject me to criminal, civil and/or administrative proceedings.

Printed Name:

Title/Position:

Signature:

Date:

Leatherleaf Solar, LLC
7501 Ivison Road
Town of Byron, New York

Appendix C: Certification Statements

Owner's/Operator's Certification

"I have read or been advised of the permit conditions and believe that I understand them. I also understand that, under the terms of the permit, there may be reporting requirements. I hereby certify that this document and the corresponding documents were prepared under my direction or supervision. I am aware that there are significant penalties for submitting false information, including the possibility of fine and imprisonment for knowing violations. I further understand that coverage under the general permit will be identified in the acknowledgment that I will receive as a result of submitting this NOI and can be as long as sixty (60) business days as provided for in the general permit. I also understand that, by submitting this NOI, I am acknowledging that the SWPPP has been developed and will be implemented as the first element of construction, and agreeing to comply with all the terms and conditions of the general permit for which this NOI is being submitted."

Name (please print) _____

Title _____ **Date** _____

Address _____

Phone _____ **Email** _____

Signature _____

Contractor's Certification

"I hereby certify under penalty of law that I understand and agree to comply with the terms and conditions of the SWPPP and agree to implement any corrective actions identified by the qualified inspector during a site inspection. I also understand that the owner or operator must comply with the terms and conditions of the most current version of the New York State Pollutant Discharge Elimination System ("SPDES") general permit for stormwater discharges from construction activities and that it is unlawful for any person to cause or contribute to a violation of water quality standards. Furthermore, I am aware that there are significant penalties for submitting false information that I do not believe to be true, including the possibility of fine and imprisonment for knowing violations."

Contracting Firm Name _____

Address _____

Phone _____ **Fax** _____

Name (please print) _____

Title _____ **Date** _____

Signature _____

SWPPP Responsibilities _____

Trained Individual Name (please print) _____

Title _____ **Date** _____

Signature _____

SWPPP Responsibilities _____

Note: All Contractors involved with Stormwater related activities shall sign a Contractor's Certification.

Subcontractor's Certification

"I hereby certify under penalty of law that I understand and agree to comply with the terms and conditions of the SWPPP and agree to implement any corrective actions identified by the qualified inspector during a site inspection. I also understand that the owner or operator must comply with the terms and conditions of the most current version of the New York State Pollutant Discharge Elimination System ("SPDES") general permit for stormwater discharges from construction activities and that it is unlawful for any person to cause or contribute to a violation of water quality standards. Furthermore, I am aware that there are significant penalties for submitting false information that I do not believe to be true, including the possibility of fine and imprisonment for knowing violations."

Subcontracting Firm Name _____

Address _____

Phone _____ **Fax** _____

Name (please print) _____

Title _____ **Date** _____

Signature _____

SWPPP Responsibilities _____

Trained Individual Name (please print) _____

Title _____ **Date** _____

Signature _____

SWPPP Responsibilities _____

Note: All subcontractors involved with Stormwater related activities shall sign a Subcontractor's Certification.

Leatherleaf Solar, LLC
7501 Ivison Road
Town of Byron, New York

Appendix D: Example Inspection Form

EXAMPLE EROSION CONTROL REPORT

PROJECT NO: _____ PROJECT NAME: _____ DATE: _____

MUNICIPALITY: _____ LOCATION: _____

CONTRACTOR: _____ OWNER: _____

DATE OF PREVIOUS INSPECTION: _____ INSPECTOR'S NAME: _____

DATE OF MOST RECENT STORM 0.5" OR GREATER: _____ DATE OF INSPECTION: _____

LAST RAIN EVENT: _____ DEPTH: _____

WEATHER: _____ TEMPERATURE: _____ °F

SPECIAL NOTES: _____

EROSION CONTROL CHECKLIST

ADDITIONAL ACTION REQUIRED BY PROJECT MANAGER OR PROJECT ENGINEER YES NO

PHOTOS OR SKETCHES ATTACHED ADDITIONAL REMARKS ATTACHED

Inspector (print name)

Inspection Date

Qualified Professional (print name)

Qualified Professional Signature

The above signed acknowledges that, to the best of his/her knowledge, all information provided on the forms is accurate and complete.

Maintaining Water Quality

Yes No NA

- Is there an increase in turbidity causing a substantial visible contrast to natural conditions?
- Is there residue from oil and floating substances, visible oil film, or globules of grease?
- All disturbance is within the limits of the approved plans.
- Have receiving lake/bay, stream, and/or wetland been impacted by silt from project?

Housekeeping

1. General Site Conditions

Yes No NA

- Is construction site litter and debris appropriately managed?
- Are facilities and equipment necessary for implementation of erosion and sediment control in working order and/or properly maintained?
- Is construction impacting the adjacent properties?
- Is dust adequately controlled?

2. Temporary Stream Crossing

Yes No NA

- Maximum diameter pipes necessary to span creek without dredging are installed.
- Installed non-woven geotextile fabric beneath approaches
- Is fill composed of aggregate (no earth or soil)?
- Rock on approaches is clean enough to remove mud from vehicles & prevent sediment from entering stream during high flow.

Runoff Control Practices

1. Excavation Dewatering

Yes No NA

- Upstream and downstream berms (sandbags, inflatable dams, etc.) are installed per plan.
- Clean water from upstream pool is being pumped to the downstream pool.
- Sediment laden water from work area is being discharged to a silt-trapping device.
- Constructed upstream berm with one-foot minimum freeboard.

2. Level Spreader

Yes No NA

- Installed per plan.
- Constructed on undisturbed soil, not on fill, receiving only clear, non-sediment laden flow.
- Flow sheets out of level spreader without erosion on downstream edge.

3. Interceptor Dikes and Swales

Yes No NA

- Installed per plan with minimum side slopes 2H:1V or flatter.
- Stabilized by geotextile fabric, seed, or mulch with no erosion occurring.
- Sediment-laden runoff directed to sediment trapping structure.

4. Stone Check Dam

Yes No NA

- Is channel stable? (flow is not eroding soil underneath or around the structure).
- Check is in good condition (rocks in place and no permanent pools behind the structure).
- Has accumulated sediment been removed?

5. Rock Outlet Protection

Yes No NA

- Installed per plan.
- Installed concurrently with pipe installation.

Soil Stabilization

1. Topsoil and Spoil Stockpiles

Yes No NA

- Stockpiles are stabilized with vegetation and/or mulch.
- Sediment control is installed at the toe of the slope.

2. Revegetation

Yes No NA

- Temporary seedings and mulch have been applied to idle areas.
- 4 inches minimum of topsoil has been applied under permanent seedings

Sediment Control Practices

1. Stabilized Construction Entrance

Yes No NA

- Stone is clean enough to effectively remove mud from vehicles.
- Installed per standards and specifications?
- Does all traffic use the stabilized entrance to enter and leave the site?
- Is adequate drainage provided to prevent ponding at entrance?

2. Silt Fence

Yes No NA

- Installed on Contour, 10 feet from toe of slope (not across conveyance channels).
- Joints constructed by wrapping the two ends together for continuous support.
- Fabric buried 6 inches minimum.
- Posts are stable, fabric is tight and without rips or frayed areas.

Sediment accumulation is _____% of design capacity.

3. Storm Drain Inlet Protection (Use for Stone & Block; Filter Fabric; Curb; or, Excavated practices)

Yes No NA

- Installed concrete blocks lengthwise so open ends face outward, not upward.
- Place wire screen between No. 3 crushed stone and concrete blocks.
- Drainage area is 1 acre or less.
- Excavated area is 900 cubic feet.
- Excavated side slopes should be 2:1.
- 2" x 4" frame is constructed and structurally sound.
- Posts 3-foot maximum spacing between posts.
- Fabric is embedded 1 to 1.5 feet below ground and secured to frame/posts with staples at max 8-inch spacing.
- Posts are stable, fabric is tight and without rips or frayed areas.

Sediment accumulation is ____% of design capacity.

4. Temporary Sediment Trap

Yes No NA

- Outlet structure is constructed per the approved plan or drawing.
- Geotextile fabric has been placed beneath rock fill.

Sediment accumulation is ____% of design capacity.

5. Temporary Sediment Basin

Yes No NA

- Basin and outlet structure constructed per the approved plan.
- Basin side slopes are stablized with seed/mulch.
- Drainage structure is flushed and basin surface restored upon removal of sediment basin facility.

Sediment accumulation is ____% of design capacity.

Leatherleaf Solar, LLC
7501 Ivison Road
Town of Byron, New York

Appendix E: Design Calculations

Total Required Water Quality Volume Calculation Worksheet

Is this project subject to Chapter 10 of the NYS Design Manual (i.e. WQv is equal to post-development 1 year runoff volume)?..... no

Design Point(s):	DP-1		<i>Manually enter the information below.</i>
P=	1.00	inch	

Breakdown of Subcatchments							
Subcatchment Number	Subcatchment Model Number	Total Area (Acres)	Impervious Area (Acres)	Percent Impervious %	Rv	WQv (ft ³)	Description
1	100	0.03	0.006	20%	0.23	25	Filter Strips
2							
3							
4							
5							
6							
7							
8							
9							
10							
Subtotal		0.03	0.01	20%	0.23	25	Subtotal 1
Total		0.03	0.01	20%	0.23	25	Initial WQv

Identify Runoff Reduction Techniques By Area			
Technique	Total Contributing Area	Contributing Impervious Area	Notes
	(Acre)	(Acre)	
Conservation of Natural Areas	0.00	0.00	<i>minimum 10,000 sf</i>
Riparian Buffers	0.00	0.00	<i>maximum contributing length 75 feet to</i>
Filter Strips	0.06	0.01	
Tree Planting	0.00	0.00	<i>Up to 100 sf directly connected</i>
Total	0.06	0.01	

Recalculate WQv after application of Area Reduction Techniques					
	Total Area (Acres)	Impervious Area (Acres)	Percent Impervious %	Runoff Coefficient Rv	WQv (ft ³)
Initial WQv	0.03	0.01	20%	0.23	25
Subtract Area	-0.06	-0.01	--	--	--
WQv adjusted after Area Reductions	-0.03	-0.01	20%	0.23	-25
Disconnection of Rooftops		0.00			
Adjusted WQv after Area Reduction and Rooftop Disconnect	-0.03	-0.01	20%	0.23	-25
WQv reduced by Area Reduction techniques					50

Subcatchment Summary Table Worksheet

All Subcatchments							
Subcatchment	Subcatchment Model	Total Area	Impervious Cover	Percent Impervious	Runoff Coefficient	WQv	Description
		<i>(Acres)</i>	<i>(Acres)</i>	%	<i>Rv</i>	<i>(ft³)</i>	
1	100	0.03	0.01	0.20	0.23	25	Filter Strips
2							
3							
4							
5							
6							
7							
8							
9							
10							
11							
12							
13							
14							
15							
16							
17							
18							
19							
20							
21							
22							
23							
24							
25							
26							
27							
28							
29							
30							

Runoff Reduction Summary Table Worksheet

Runoff Reduction Volume and Treated Volumes						
Runoff Reduction Techniques/Standard SMPs			Total Contributing Area (acres)	Total Contributing Impervious Area (acres)	WQv Reduced (RRv) cf	WQv Treated cf
Area Reduction	Conservation of Natural Areas	RR-1	0.00	0.00		
	Sheet flow to Riparian Buffers	RR-2	0.00	0.00		
	Sheet flow to Filter Strips		0.06	0.01		
	Tree Planting/Tree Pit	RR-3	0.00	0.00		
	Disconnection of Rooftop Runoff	RR-4		0.00		
Volume Reduction	Vegetated Swale	RR-5	0.00	0.00	0	
	Rain Garden	RR-6	0.00	0.00	0	
	Stormwater Planter	RR-7	0.00	0.00	0	
	Rain Barrel/Cistern	RR-8	0.00	0.00	0	
	Porous Pavement	RR-9	0.00	0.00	0	
	Green Roof (Intensive)	RR-10	0.00	0.00	0	
	Green Roof (Extensive)		0.00	0.00	0	
Standard SMPs w/RRv Capacity	Infiltration Trench	I-1	0.00	0.00	0	0
	Infiltration Basin	I-2	0.00	0.00	0	0
	Dry Well	I-3	0.00	0.00	0	0
	Underground Infiltration System	I-4	0.00	0.00	0	0
	Bioretention	F-5	0.00	0.00	0	0
	Infiltration Bioretention		0.00	0.00	0	0
	Dry swale	O-1	0.00	0.00		0
Standard SMPs	Micropool Extended Detention Pond	P-1	0.00	0.00		0
	Wet Pond	P-2	0.00	0.00		0
	Wet Extended Detention Pond	P-3	0.00	0.00		0
	Multiple Pond system	P-4	0.00	0.00		0
	Pocket Pond	P-5	0.00	0.00		0
	Surface Sand Filter	F-1	0.00	0.00		0
	Underground Sand Filter	F-2	0.00	0.00		0
	Perimeter Sand Filter	F-3	0.00	0.00		0
	Organic Filter	F-4	0.00	0.00		0
	Shallow Wetland	W-1	0.00	0.00		0
	Extended Detention Shallow Wetland	W-2	0.00	0.00		0
	Pond/Wetland System	W-3	0.00	0.00		0
	Pocket Wetland	W-4	0.00	0.00		0
	Wet Swale	O-2	0.00	0.00		0
Totals by Area Reduction →			0.06	0.01	50	
Totals by Volume Reduction →			0.00	0.00	0	
Totals by Standard SMP w/RRV →			0.00	0.00	0	0
Totals by Standard SMP →			0.00	0.00		0
Totals (Area + Volume + all SMPs) →			0.06	0.01	50	0

Minimum Runoff Reduction Volume Worksheet

Minimum Runoff Reduction Volume			
1. Construction activities that cannot achieve 100% reduction of the total water quality volume due to site limitation shall direct runoff from all newly constructed impervious areas to a runoff reduction technique or standard stormwater management practice with runoff reduction volume capacity unless infeasible.			
2. In no case shall the runoff reduction achieved from the newly constructed impervious areas be less than the minimum runoff reduction (RRv_{min}).			
3. The minimum runoff reduction volume is calculated as follows:			
$RRv_{min} = \frac{P * \bar{R}v * Aic * S}{12}$			
Where:			
<i>RRv_{min}</i> = Minimum runoff reduction required from impervious area			
<i>$\bar{R}v$</i> = 0.05 + 0.009 (I), where I is 100% impervious			
<i>Aic</i> = Total area of new impervious cover			
<i>S</i> = Hydrologic Soil Group Specific Reduction Factor			

Enter the Soils Data for the site			
Soil Group	Acres	S	
A	0.00	55%	<i>(new impervious area in Type A Soils)</i>
B	0.00	40%	<i>(new impervious area in Type B Soils)</i>
C	0.00	30%	<i>(new impervious area in Type C Soils)</i>
D	0.01	20%	<i>(new impervious area in Type D Soils)</i>
Total Area	0.01		
Calculate the Minimum RRv			
Soil Group Specific Reduction Factor (S)	0.20		<i>(weighted average)</i>
Total Area of New Impervious Cover (Aic)	0.01	<i>acre</i>	
Precipitation (P)	1.00	<i>in</i>	
Rv	0.95		
Minimum RRv	4	ft³	<i>(P * Rv x Aic * S)/12</i>
	0.00	<i>af</i>	

Notice of Intent Questions Worksheet

#	NOI Question	Reported Value	
		cf	af
		cf	af
28	Total Water Quality Volume (WQv) Required	25	0.001
30	Total RRV Provided	50	0.001
31	Is RRV Provided \geq WQv Required?	Yes	
32	Minimum RRV	4	0.000
32a	Is RRV Provided \geq Minimum RRV Required?	Yes	Conditions Met
33a	Total WQv Treated	0	0.000
34	Sum of Volume Reduced & Treated	50	0.001
35	Is Sum RRV Provided and WQv Provided \geq WQv Required?	Yes	Conditions Met
Apply Peak Flow Attenuation			
		af	af
36	Channel Protection	C_{pv}	0.000
		cfs	cfs
37	Overbank	Q_p	29.18
37	Extreme Flood Control	Q_f	103.89
	Are Quantity Control requirements met?	Yes	Plan Completed

Planning Worksheet

Practice	Description	Application
Preservation of Undisturbed Areas	Delineate and place into permanent conservation undisturbed forests, native vegetated areas, riparian corridors, wetlands, and natural terrain.	<i>Considered and Not Applied</i>
Preservation of Buffers	Define, delineate and preserve naturally vegetated buffers along perennial streams, rivers, shorelines and wetlands.	<i>Considered and Not Applied</i>
Reduction of Clearing and Grading	Limit clearing and grading to the minimum amount needed for roads, driveways, foundations, utilities and stormwater management facilities.	<i>Considered and Applied</i>
Locating Development in Less Sensitive Areas	Avoid sensitive resource areas such as floodplains, steep slopes, erodible soils, wetlands, mature forests and critical habitats by locating development to fit the terrain in areas that will create the least impact.	<i>Considered and Applied</i>
Open Space Design	Use clustering, conservation design or open space design to reduce impervious cover, preserve more open space and protect water resources.	N/A
Soil Restoration	Restore the original properties and porosity of the soil by deep till and amendment with compost to reduce the generation of runoff and enhance the runoff reduction performance of post construction practices.	<i>Considered and Applied</i>
Roadway Reduction	Minimize roadway widths and lengths to reduce site impervious area	N/A
Sidewalk Reduction	Minimize sidewalk lengths and widths to reduce site impervious area	N/A
Driveway Reduction	Minimize driveway lengths and widths to reduce site impervious area	<i>Considered and Applied</i>
Cul-de-sac Reduction	Minimize the number of cul-de-sacs and incorporate landscaped areas to reduce their impervious cover.	N/A
Building Footprint Reduction	Reduce the impervious footprint of residences and commercial buildings by using alternate or taller buildings while maintaining the same floor to area ratio.	N/A
Parking Reduction	Reduce imperviousness on parking lots by eliminating unneeded spaces, providing compact car spaces and efficient parking lanes, minimizing stall dimensions, using porous pavement surfaces in overflow parking areas, and using multi-storied parking decks where appropriate.	N/A

Filter Strips Worksheet

Design Point(s):	DP-1							
Enter Site Data For Drainage Area to be Treated by Practice								
Subcatchment Number	Subcatchment Model Number	Total Area (Acres)	Impervious Area (Acres)	Percent Impervious %	Rv	WQv (ft ³)	Precipitation (in)	Description
1	100A	0.03	0.01	0.20	0.23	25	1.00	Filter Strips
Design Elements								
Is another area based practice applied to this area?				no	Y/N			
Amended Soils & Dense Turf Cover?				yes	Y/N			
Is area protected from compaction from heavy equipment during construction?				yes	Y/N			
Small Area of Impervious Area & close to source?				yes	Y/N			
Compost Amendments?				yes	Y/N			
Boundary Spreader?				yes	Y/N	<i>Gravel Diaphragm at top Permeable Berm at bottom</i>		
Boundary Zone?				yes	Y/N	<i>25 feet of level grass</i>		
Specify how sheet flow will be ensured.				Filter strip shall be adjacent to impervious area		<i>level spreader shall be used for buffer slopes ranging from 3-15%</i>		
Average contributing slope				0	%	<i>3% maximum unless a level spreader is used.</i>		
Slope of first 10 feet of Filter Strip				2	%	<i>2% maximum</i>		
Overall Slope				4.5	%	<i>8% maximum</i>		
Contributing Length of Pervious Areas (PC)				0	ft.	<i>150 ft. maximum</i>		
Contributing Length of Impervious areas (IC)				20	ft	<i>75 ft maximum</i>		
Maximum PC Contributing Length for combination of PC & IC				20	ft	<i>Okay</i>		
Soil Group (HSG)				D				
Filter Strip Width				50	ft	<i>50 ft minimum for slopes 0-8% 75 ft minimum for slopes 8-12% 100 ft minimum for slopes 12-15% HSG C or D increase by 15-20%</i>		
Are All Criteria for Filter Strips in Section 5.3.2 met?				yes	Y/N			
Area Reduction Adjustments								
				Subtract	0.03	<i>Acres from total Area</i>		
				Subtract	0.01	<i>Acres from total Impervious Area</i>		

Filter Strips Worksheet

Design Point(s):	DP-1							
Enter Site Data For Drainage Area to be Treated by Practice								
Subcatchment Number	Subcatchment Model Number	Total Area (Acres)	Impervious Area (Acres)	Percent Impervious %	Rv	WQv (ft ³)	Precipitation (in)	Description
1	100B	0.03	0.01	0.20	0.23	25	1.00	Filter Strips
Design Elements								
Is another area based practice applied to this area?				no	Y/N			
Amended Soils & Dense Turf Cover?				yes	Y/N			
Is area protected from compaction from heavy equipment during construction?				yes	Y/N			
Small Area of Impervious Area & close to source?				yes	Y/N			
Compost Amendments?				yes	Y/N			
Boundary Spreader?				yes	Y/N	<i>Gravel Diaphragm at top Permeable Berm at bottom</i>		
Boundary Zone?				yes	Y/N	<i>25 feet of level grass</i>		
Specify how sheet flow will be ensured.				Filter strip shall be adjacent to impervious area		<i>level spreader shall be used for buffer slopes ranging from 3-15%</i>		
Average contributing slope				0	%	<i>3% maximum unless a level spreader is used.</i>		
Slope of first 10 feet of Filter Strip				2	%	<i>2% maximum</i>		
Overall Slope				4.5	%	<i>8% maximum</i>		
Contributing Length of Pervious Areas (PC)				0	ft.	<i>150 ft. maximum</i>		
Contributing Length of Impervious areas (IC)				20	ft	<i>75 ft maximum</i>		
Maximum PC Contributing Length for combination of PC & IC				20	ft	<i>Okay</i>		
Soil Group (HSG)				D				
Filter Strip Width				50	ft	<i>50 ft minimum for slopes 0-8% 75 ft minimum for slopes 8-12% 100 ft minimum for slopes 12-15% HSG C or D increase by 15-20%</i>		
Are All Criteria for Filter Strips in Section 5.3.2 met?				yes	Y/N			
Area Reduction Adjustments								
Subtract				0.03	<i>Acres from total Area</i>			
Subtract				0.01	<i>Acres from total Impervious Area</i>			

Extreme Precipitation Tables

Northeast Regional Climate Center

Data represents point estimates calculated from partial duration series. All precipitation amounts are displayed in inches.

Metadata for Point

Smoothing	Yes
State	
Location	
Latitude	43.039 degrees North
Longitude	78.045 degrees West
Elevation	220 feet
Date/Time	Wed Feb 22 2023 19:50:44 GMT-0500 (Eastern Standard Time)

Extreme Precipitation Estimates

	5min	10min	15min	30min	60min	120min		1hr	2hr	3hr	6hr	12hr	24hr	48hr		1day	2day	4d
1yr	0.25	0.39	0.48	0.64	0.79	0.97	1yr	0.68	0.84	1.10	1.32	1.57	1.85	2.05	1yr	1.63	1.97	2.4
2yr	0.29	0.45	0.56	0.74	0.93	1.15	2yr	0.81	1.03	1.30	1.55	1.83	2.14	2.40	2yr	1.90	2.31	2.7
5yr	0.35	0.54	0.68	0.91	1.16	1.44	5yr	1.00	1.29	1.63	1.93	2.26	2.61	2.94	5yr	2.31	2.83	3.3
10yr	0.39	0.61	0.77	1.05	1.37	1.70	10yr	1.18	1.53	1.93	2.28	2.65	3.02	3.43	10yr	2.68	3.30	3.8
25yr	0.46	0.73	0.93	1.28	1.71	2.13	25yr	1.47	1.92	2.41	2.83	3.25	3.67	4.20	25yr	3.25	4.04	4.6
50yr	0.52	0.84	1.07	1.50	2.02	2.52	50yr	1.74	2.28	2.85	3.34	3.81	4.26	4.89	50yr	3.77	4.71	5.3
100yr	0.59	0.95	1.23	1.75	2.39	2.99	100yr	2.06	2.71	3.38	3.93	4.45	4.94	5.71	100yr	4.38	5.49	6.2
200yr	0.68	1.10	1.43	2.05	2.83	3.55	200yr	2.44	3.22	4.00	4.63	5.21	5.74	6.66	200yr	5.08	6.40	7.2
500yr	0.81	1.34	1.74	2.53	3.54	4.44	500yr	3.05	4.05	4.99	5.74	6.40	6.99	8.16	500yr	6.18	7.85	8.8

Lower Confidence Limits

	5min	10min	15min	30min	60min	120min		1hr	2hr	3hr	6hr	12hr	24hr	48hr		1day	2day	4d
1yr	0.20	0.30	0.37	0.50	0.61	0.75	1yr	0.53	0.74	0.81	1.11	1.35	1.62	1.80	1yr	1.43	1.73	2.0
2yr	0.28	0.44	0.54	0.73	0.90	1.01	2yr	0.78	0.99	1.11	1.38	1.64	2.09	2.34	2yr	1.85	2.25	2.6
5yr	0.32	0.49	0.60	0.83	1.05	1.17	5yr	0.91	1.15	1.29	1.58	1.92	2.45	2.75	5yr	2.17	2.64	3.1
10yr	0.34	0.52	0.65	0.91	1.17	1.30	10yr	1.01	1.28	1.43	1.74	2.12	2.76	3.11	10yr	2.44	3.00	3.5
25yr	0.38	0.58	0.72	1.02	1.35	1.49	25yr	1.16	1.45	1.61	1.98	2.42	3.22	3.68	25yr	2.85	3.54	4.2
50yr	0.41	0.62	0.77	1.11	1.49	1.61	50yr	1.29	1.58	1.75	2.17	2.66	3.63	4.19	50yr	3.21	4.03	4.7
100yr	0.44	0.67	0.84	1.21	1.66	1.77	100yr	1.44	1.73	1.88	2.39	2.91	4.10	4.78	100yr	3.63	4.59	5.2
200yr	0.47	0.71	0.90	1.31	1.83	1.93	200yr	1.58	1.89	2.03	2.62	3.18	4.62	5.45	200yr	4.09	5.24	6.0
500yr	0.53	0.78	1.01	1.47	2.08	2.15	500yr	1.80	2.10	2.21	2.95	3.57	5.44	6.50	500yr	4.82	6.25	7.0

Upper Confidence Limits

	5min	10min	15min	30min	60min	120min		1hr	2hr	3hr	6hr	12hr	24hr	48hr		1day	2day	4d
1yr	0.29	0.44	0.54	0.72	0.89	0.96	1yr	0.77	0.93	1.13	1.41	1.71	2.00	2.21	1yr	1.77	2.13	2.5
2yr	0.31	0.49	0.60	0.81	1.00	1.13	2yr	0.86	1.10	1.25	1.51	1.81	2.22	2.48	2yr	1.96	2.38	2.8
5yr	0.38	0.59	0.73	1.00	1.28	1.48	5yr	1.10	1.45	1.61	1.97	2.35	2.75	3.14	5yr	2.44	3.02	3.4
10yr	0.46	0.70	0.87	1.21	1.57	1.84	10yr	1.35	1.80	1.98	2.42	2.89	3.26	3.75	10yr	2.89	3.61	4.0
25yr	0.58	0.88	1.10	1.57	2.06	2.47	25yr	1.78	2.42	2.64	3.20	3.82	4.08	4.75	25yr	3.61	4.56	5.1
50yr	0.69	1.06	1.32	1.89	2.55	3.08	50yr	2.20	3.01	3.28	3.96	4.73	4.83	5.68	50yr	4.28	5.46	6.0
100yr	0.84	1.27	1.59	2.30	3.15	3.83	100yr	2.72	3.75	4.11	4.90	5.86	5.72	6.78	100yr	5.07	6.52	7.1
200yr	1.01	1.52	1.93	2.80	3.90	4.78	200yr	3.37	4.67	5.15	6.08	7.26	6.76	8.09	200yr	5.98	7.78	8.4
500yr	1.31	1.95	2.51	3.64	5.18	6.44	500yr	4.47	6.30	6.97	8.12	9.64	8.44	10.21	500yr	7.47	9.82	10.

Leatherleaf Solar, LLC
7501 Ivison Road
Town of Byron, New York

Appendix F: Pre-Development Stormwater Analysis

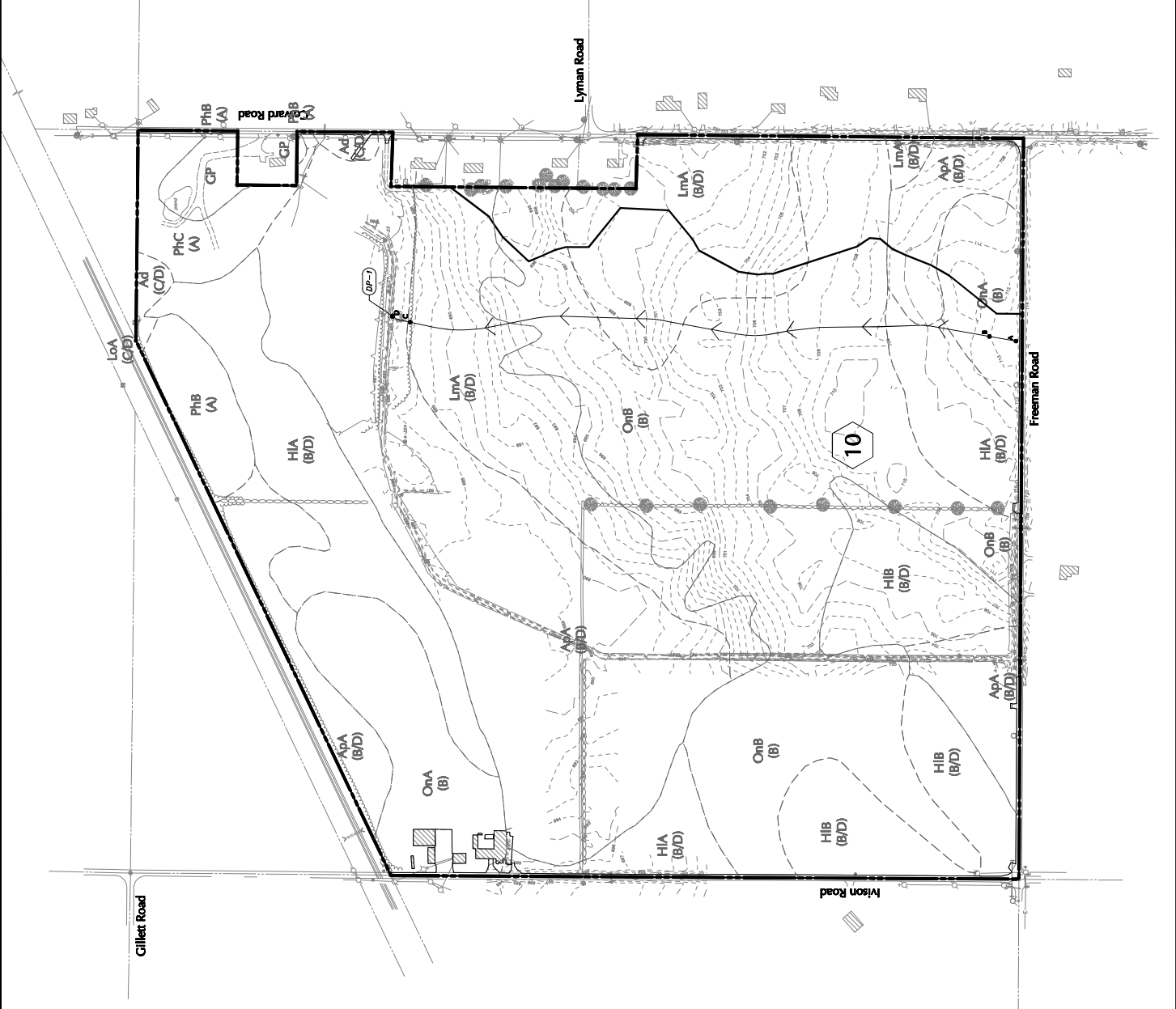

Date	Description	No.
	Revisions	

Signature	Date
-----------	------

LANGAN
LANGAN Engineering, Environmental, Surveying
Landscape Architecture and Planning, P.C.
One Langan Way
White Plains, NY 10606
T: 914.321.7400 F: 914.321.7401 www.langan.com

LEATHERLEAF SOLAR, LLC
20402-041118
TOWN OF FRENCH CREEK
GREENE COUNTY, NEW YORK

PRE DEVELOPMENT WATERSHED MAP

PROJECT No.	11850001
DATE	03/20/2023
Drawn By	CMC/MS
Checked By	SM/CM

FIGURE
FG05

Sheet 1 of 4

1" = 100'
0 50 100 150
FOOT

WARNING: IT IS A VIOLATION OF THE NYS
ELECTRICITY AND GAS LAW TO CONDUCT ANY
ELECTRICITY OR GAS WORK WITHOUT THE
APPROPRIATE LICENSES FROM THE STATE
DEPARTMENT OF CONSUMER SERVICES.

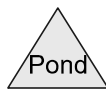
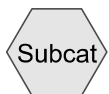
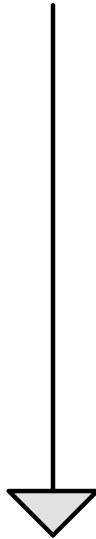
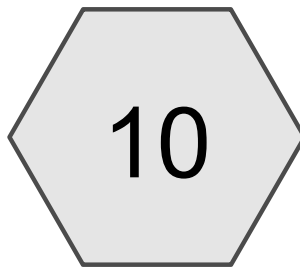

2023-02-24 existing

Prepared by Langan Engineering

HydroCAD® 10.20-2f s/n 08223 © 2022 HydroCAD Software Solutions LLC

Printed 2/24/2023

Page 2

Rainfall Events Listing

Event#	Event Name	Storm Type	Curve	Mode	Duration (hours)	B/B	Depth (inches)	AMC
1	1-Year	Type II 24-hr		Default	24.00	1	1.57	2
2	10-Year	Type II 24-hr		Default	24.00	1	2.65	2
3	100-Year	Type II 24-hr		Default	24.00	1	4.45	2

2023-02-24 existing

Type II 24-hr 1-Year Rainfall=1.57"

Prepared by Langan Engineering

Printed 2/24/2023

HydroCAD® 10.20-2f s/n 08223 © 2022 HydroCAD Software Solutions LLC

Page 3

Time span=0.00-72.00 hrs, dt=0.01 hrs, 7201 points
Runoff by SCS TR-20 method, UH=SCS, Weighted-CN
Reach routing by Stor-Ind+Trans method - Pond routing by Stor-Ind method

Subcatchment10:

Runoff Area=162.240 ac 6.64% Impervious Runoff Depth=0.12"
Flow Length=2,330' Tc=90.2 min CN=71 Runoff=3.49 cfs 1.585 af

Reach DP1:

Inflow=3.49 cfs 1.585 af
Outflow=3.49 cfs 1.585 af

Summary for Subcatchment 10:

Runoff = 3.49 cfs @ 13.52 hrs, Volume= 1.585 af, Depth= 0.12"
 Routed to Reach DP1 :

Runoff by SCS TR-20 method, UH=SCS, Weighted-CN, Time Span= 0.00-72.00 hrs, dt= 0.01 hrs
 Type II 24-hr 1-Year Rainfall=1.57"

Area (ac)	CN	Description
5.160	30	Meadow, non-grazed, HSG A
52.400	58	Meadow, non-grazed, HSG B
84.040	78	Meadow, non-grazed, HSG D
2.000	36	Woods, Fair, HSG A
0.040	60	Woods, Fair, HSG B
7.820	79	Woods, Fair, HSG D
10.780	98	Paved parking, HSG A
162.240	71	Weighted Average
151.460		93.36% Pervious Area
10.780		6.64% Impervious Area

Tc (min)	Length (feet)	Slope (ft/ft)	Velocity (ft/sec)	Capacity (cfs)	Description
41.4	100	0.0028	0.04		Sheet Flow, A-B Grass: Dense n= 0.240 P2= 1.83"
47.6	2,161	0.0117	0.76		Shallow Concentrated Flow, B-C Short Grass Pasture Kv= 7.0 fps
1.2	69	0.0344	0.93		Shallow Concentrated Flow, C-D Woodland Kv= 5.0 fps
90.2	2,330	Total			

2023-02-24 existing

Prepared by Langan Engineering

HydroCAD® 10.20-2f s/n 08223 © 2022 HydroCAD Software Solutions LLC

Type II 24-hr 1-Year Rainfall=1.57"

Printed 2/24/2023

Page 5

Summary for Reach DP1:

[40] Hint: Not Described (Outflow=Inflow)

Inflow Area = 162.240 ac, 6.64% Impervious, Inflow Depth = 0.12" for 1-Year event

Inflow = 3.49 cfs @ 13.52 hrs, Volume= 1.585 af

Outflow = 3.49 cfs @ 13.52 hrs, Volume= 1.585 af, Atten= 0%, Lag= 0.0 min

Routing by Stor-Ind+Trans method, Time Span= 0.00-72.00 hrs, dt= 0.01 hrs

2023-02-24 existing

Prepared by Langan Engineering

HydroCAD® 10.20-2f s/n 08223 © 2022 HydroCAD Software Solutions LLC

Type II 24-hr 10-Year Rainfall=2.65"

Printed 2/24/2023

Page 6

Time span=0.00-72.00 hrs, dt=0.01 hrs, 7201 points
Runoff by SCS TR-20 method, UH=SCS, Weighted-CN
Reach routing by Stor-Ind+Trans method - Pond routing by Stor-Ind method

Subcatchment10:

Runoff Area=162.240 ac 6.64% Impervious Runoff Depth=0.57"
Flow Length=2,330' Tc=90.2 min CN=71 Runoff=29.18 cfs 7.677 af

Reach DP1:

Inflow=29.18 cfs 7.677 af
Outflow=29.18 cfs 7.677 af

Summary for Subcatchment 10:

Runoff = 29.18 cfs @ 13.13 hrs, Volume= 7.677 af, Depth= 0.57"
 Routed to Reach DP1 :

Runoff by SCS TR-20 method, UH=SCS, Weighted-CN, Time Span= 0.00-72.00 hrs, dt= 0.01 hrs
 Type II 24-hr 10-Year Rainfall=2.65"

Area (ac)	CN	Description
5.160	30	Meadow, non-grazed, HSG A
52.400	58	Meadow, non-grazed, HSG B
84.040	78	Meadow, non-grazed, HSG D
2.000	36	Woods, Fair, HSG A
0.040	60	Woods, Fair, HSG B
7.820	79	Woods, Fair, HSG D
10.780	98	Paved parking, HSG A
162.240	71	Weighted Average
151.460		93.36% Pervious Area
10.780		6.64% Impervious Area

Tc (min)	Length (feet)	Slope (ft/ft)	Velocity (ft/sec)	Capacity (cfs)	Description
41.4	100	0.0028	0.04		Sheet Flow, A-B
					Grass: Dense n= 0.240 P2= 1.83"
47.6	2,161	0.0117	0.76		Shallow Concentrated Flow, B-C
					Short Grass Pasture Kv= 7.0 fps
1.2	69	0.0344	0.93		Shallow Concentrated Flow, C-D
					Woodland Kv= 5.0 fps
90.2	2,330	Total			

Summary for Reach DP1:

[40] Hint: Not Described (Outflow=Inflow)

Inflow Area = 162.240 ac, 6.64% Impervious, Inflow Depth = 0.57" for 10-Year event
Inflow = 29.18 cfs @ 13.13 hrs, Volume= 7.677 af
Outflow = 29.18 cfs @ 13.13 hrs, Volume= 7.677 af, Atten= 0%, Lag= 0.0 min

Routing by Stor-Ind+Trans method, Time Span= 0.00-72.00 hrs, dt= 0.01 hrs

2023-02-24 existing

Prepared by Langan Engineering

HydroCAD® 10.20-2f s/n 08223 © 2022 HydroCAD Software Solutions LLC

Type II 24-hr 100-Year Rainfall=4.45"

Printed 2/24/2023

Page 9

Time span=0.00-72.00 hrs, dt=0.01 hrs, 7201 points
Runoff by SCS TR-20 method, UH=SCS, Weighted-CN
Reach routing by Stor-Ind+Trans method - Pond routing by Stor-Ind method

Subcatchment10:

Runoff Area=162.240 ac 6.64% Impervious Runoff Depth=1.71"
Flow Length=2,330' Tc=90.2 min CN=71 Runoff=103.89 cfs 23.123 af

Reach DP1:

Inflow=103.89 cfs 23.123 af
Outflow=103.89 cfs 23.123 af

Summary for Subcatchment 10:

Runoff = 103.89 cfs @ 13.12 hrs, Volume= 23.123 af, Depth= 1.71"
 Routed to Reach DP1 :

Runoff by SCS TR-20 method, UH=SCS, Weighted-CN, Time Span= 0.00-72.00 hrs, dt= 0.01 hrs
 Type II 24-hr 100-Year Rainfall=4.45"

Area (ac)	CN	Description
5.160	30	Meadow, non-grazed, HSG A
52.400	58	Meadow, non-grazed, HSG B
84.040	78	Meadow, non-grazed, HSG D
2.000	36	Woods, Fair, HSG A
0.040	60	Woods, Fair, HSG B
7.820	79	Woods, Fair, HSG D
10.780	98	Paved parking, HSG A
162.240	71	Weighted Average
151.460		93.36% Pervious Area
10.780		6.64% Impervious Area

Tc (min)	Length (feet)	Slope (ft/ft)	Velocity (ft/sec)	Capacity (cfs)	Description
41.4	100	0.0028	0.04		Sheet Flow, A-B
					Grass: Dense n= 0.240 P2= 1.83"
47.6	2,161	0.0117	0.76		Shallow Concentrated Flow, B-C
					Short Grass Pasture Kv= 7.0 fps
1.2	69	0.0344	0.93		Shallow Concentrated Flow, C-D
					Woodland Kv= 5.0 fps
90.2	2,330	Total			

Summary for Reach DP1:

[40] Hint: Not Described (Outflow=Inflow)

Inflow Area = 162.240 ac, 6.64% Impervious, Inflow Depth = 1.71" for 100-Year event
Inflow = 103.89 cfs @ 13.12 hrs, Volume= 23.123 af
Outflow = 103.89 cfs @ 13.12 hrs, Volume= 23.123 af, Atten= 0%, Lag= 0.0 min

Routing by Stor-Ind+Trans method, Time Span= 0.00-72.00 hrs, dt= 0.01 hrs

Leatherleaf Solar, LLC
7501 Ivison Road
Town of Byron, New York

Appendix G: Post-Development Stormwater Analysis

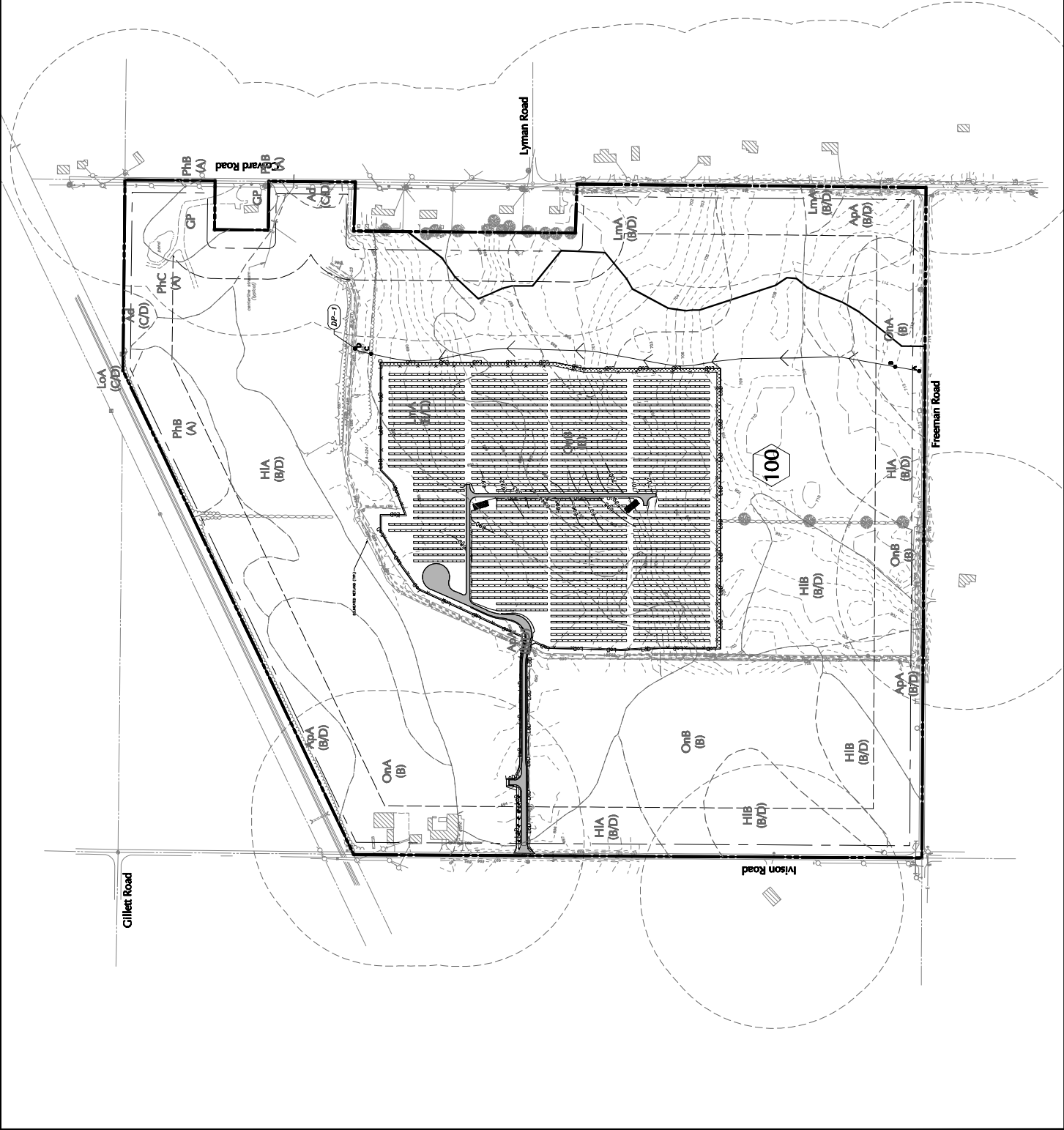

Date	Description	No.
	Revisions	

Signature	Date
-----------	------

LANGAN Langan Engineering, Environmental, Science & Technology Landscape Architecture and Geology, P.C. One Langan Way White Plains, NY 10604 T: 914.327.7400 F: 914.327.7401 www.langan.com	LEATHERLEAF SOLAR, LLC WARD-1-14113 TOWN OF FRENCH CREEK NEW YORK
--	---

PROJECT	FIGURE
DATE	1/15/2019
DRAWN BY	CMON
CHECKED BY	CMON

PROJECT No.	14113	FIGURE	FG06
DRAWING TITLE	POST DEVELOPMENT WATERSHED MAP		

Scale	1" = 100'
Scale	1" = 200'
Scale	1" = 400'
Scale	1" = 800'
Scale	1" = 1600'

WARNING: IT IS A VIOLATION OF THE NYS SOLAR LAW TO REPRODUCE OR TRANSMIT THIS MAP WITHOUT THE WRITTEN PERMISSION OF LEATHERLEAF SOLAR, LLC.

DATE PLOTTED: 1/15/2019 10:58 AM USER: BILLY.MCCARTHY TITLE: POST DEVELOPMENT WATERSHED MAP FIGURE: FG06

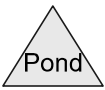
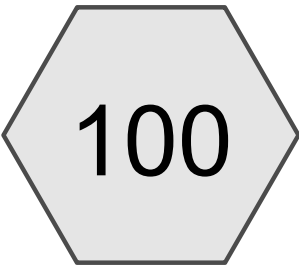

2023-02-24 proposed

Prepared by Langan Engineering

HydroCAD® 10.20-2f s/n 08223 © 2022 HydroCAD Software Solutions LLC

Printed 2/24/2023

Page 2

Rainfall Events Listing

Event#	Event Name	Storm Type	Curve	Mode	Duration (hours)	B/B	Depth (inches)	AMC
1	1-Year	Type II 24-hr		Default	24.00	1	1.57	2
2	10-Year	Type II 24-hr		Default	24.00	1	2.65	2
3	100-Year	Type II 24-hr		Default	24.00	1	4.45	2

2023-02-24 proposed

Type II 24-hr 1-Year Rainfall=1.57"

Prepared by Langan Engineering

Printed 2/24/2023

HydroCAD® 10.20-2f s/n 08223 © 2022 HydroCAD Software Solutions LLC

Page 3

Time span=0.00-72.00 hrs, dt=0.01 hrs, 7201 points
Runoff by SCS TR-20 method, UH=SCS, Weighted-CN
Reach routing by Stor-Ind+Trans method - Pond routing by Stor-Ind method

Subcatchment100:

Runoff Area=162.240 ac 6.50% Impervious Runoff Depth=0.12"
Flow Length=2,330' Tc=90.2 min CN=71 Runoff=3.49 cfs 1.585 af

Reach DP1:

Inflow=3.49 cfs 1.585 af
Outflow=3.49 cfs 1.585 af

Summary for Subcatchment 100:

Runoff = 3.49 cfs @ 13.52 hrs, Volume= 1.585 af, Depth= 0.12"
 Routed to Reach DP1 :

Runoff by SCS TR-20 method, UH=SCS, Weighted-CN, Time Span= 0.00-72.00 hrs, dt= 0.01 hrs
 Type II 24-hr 1-Year Rainfall=1.57"

Area (ac)	CN	Description
5.160	30	Meadow, non-grazed, HSG A
52.220	58	Meadow, non-grazed, HSG B
83.220	78	Meadow, non-grazed, HSG D
2.000	36	Woods, Fair, HSG A
0.040	60	Woods, Fair, HSG B
7.820	79	Woods, Fair, HSG D
10.540	98	Paved parking, HSG A
* 1.240	96	Permeable Haul Road
162.240	71	Weighted Average
151.700		93.50% Pervious Area
10.540		6.50% Impervious Area

Tc (min)	Length (feet)	Slope (ft/ft)	Velocity (ft/sec)	Capacity (cfs)	Description
41.4	100	0.0028	0.04		Sheet Flow, A-B Grass: Dense n= 0.240 P2= 1.83"
47.6	2,161	0.0117	0.76		Shallow Concentrated Flow, B-C Short Grass Pasture Kv= 7.0 fps
1.2	69	0.0344	0.93		Shallow Concentrated Flow, C-D Woodland Kv= 5.0 fps
90.2	2,330	Total			

2023-02-24 proposed

Prepared by Langan Engineering

HydroCAD® 10.20-2f s/n 08223 © 2022 HydroCAD Software Solutions LLC

Type II 24-hr 1-Year Rainfall=1.57"

Printed 2/24/2023

Page 5

Summary for Reach DP1:

[40] Hint: Not Described (Outflow=Inflow)

Inflow Area = 162.240 ac, 6.50% Impervious, Inflow Depth = 0.12" for 1-Year event
Inflow = 3.49 cfs @ 13.52 hrs, Volume= 1.585 af
Outflow = 3.49 cfs @ 13.52 hrs, Volume= 1.585 af, Atten= 0%, Lag= 0.0 min

Routing by Stor-Ind+Trans method, Time Span= 0.00-72.00 hrs, dt= 0.01 hrs

2023-02-24 proposed

Prepared by Langan Engineering

HydroCAD® 10.20-2f s/n 08223 © 2022 HydroCAD Software Solutions LLC

Type II 24-hr 10-Year Rainfall=2.65"

Printed 2/24/2023

Page 6

Time span=0.00-72.00 hrs, dt=0.01 hrs, 7201 points
Runoff by SCS TR-20 method, UH=SCS, Weighted-CN
Reach routing by Stor-Ind+Trans method - Pond routing by Stor-Ind method

Subcatchment100:

Runoff Area=162.240 ac 6.50% Impervious Runoff Depth=0.57"
Flow Length=2,330' Tc=90.2 min CN=71 Runoff=29.18 cfs 7.677 af

Reach DP1:

Inflow=29.18 cfs 7.677 af
Outflow=29.18 cfs 7.677 af

Summary for Subcatchment 100:

Runoff = 29.18 cfs @ 13.13 hrs, Volume= 7.677 af, Depth= 0.57"
 Routed to Reach DP1 :

Runoff by SCS TR-20 method, UH=SCS, Weighted-CN, Time Span= 0.00-72.00 hrs, dt= 0.01 hrs
 Type II 24-hr 10-Year Rainfall=2.65"

Area (ac)	CN	Description
5.160	30	Meadow, non-grazed, HSG A
52.220	58	Meadow, non-grazed, HSG B
83.220	78	Meadow, non-grazed, HSG D
2.000	36	Woods, Fair, HSG A
0.040	60	Woods, Fair, HSG B
7.820	79	Woods, Fair, HSG D
10.540	98	Paved parking, HSG A
* 1.240	96	Permeable Haul Road
162.240	71	Weighted Average
151.700		93.50% Pervious Area
10.540		6.50% Impervious Area

Tc (min)	Length (feet)	Slope (ft/ft)	Velocity (ft/sec)	Capacity (cfs)	Description
41.4	100	0.0028	0.04		Sheet Flow, A-B Grass: Dense n= 0.240 P2= 1.83"
47.6	2,161	0.0117	0.76		Shallow Concentrated Flow, B-C Short Grass Pasture Kv= 7.0 fps
1.2	69	0.0344	0.93		Shallow Concentrated Flow, C-D Woodland Kv= 5.0 fps
90.2	2,330	Total			

Summary for Reach DP1:

[40] Hint: Not Described (Outflow=Inflow)

Inflow Area = 162.240 ac, 6.50% Impervious, Inflow Depth = 0.57" for 10-Year event
Inflow = 29.18 cfs @ 13.13 hrs, Volume= 7.677 af
Outflow = 29.18 cfs @ 13.13 hrs, Volume= 7.677 af, Atten= 0%, Lag= 0.0 min

Routing by Stor-Ind+Trans method, Time Span= 0.00-72.00 hrs, dt= 0.01 hrs

2023-02-24 proposed

Type II 24-hr 100-Year Rainfall=4.45"

Prepared by Langan Engineering

Printed 2/24/2023

HydroCAD® 10.20-2f s/n 08223 © 2022 HydroCAD Software Solutions LLC

Page 9

Time span=0.00-72.00 hrs, dt=0.01 hrs, 7201 points
Runoff by SCS TR-20 method, UH=SCS, Weighted-CN
Reach routing by Stor-Ind+Trans method - Pond routing by Stor-Ind method

Subcatchment100:

Runoff Area=162.240 ac 6.50% Impervious Runoff Depth=1.71"
Flow Length=2,330' Tc=90.2 min CN=71 Runoff=103.89 cfs 23.123 af

Reach DP1:

Inflow=103.89 cfs 23.123 af
Outflow=103.89 cfs 23.123 af

Summary for Subcatchment 100:

Runoff = 103.89 cfs @ 13.12 hrs, Volume= 23.123 af, Depth= 1.71"
 Routed to Reach DP1 :

Runoff by SCS TR-20 method, UH=SCS, Weighted-CN, Time Span= 0.00-72.00 hrs, dt= 0.01 hrs
 Type II 24-hr 100-Year Rainfall=4.45"

Area (ac)	CN	Description
5.160	30	Meadow, non-grazed, HSG A
52.220	58	Meadow, non-grazed, HSG B
83.220	78	Meadow, non-grazed, HSG D
2.000	36	Woods, Fair, HSG A
0.040	60	Woods, Fair, HSG B
7.820	79	Woods, Fair, HSG D
10.540	98	Paved parking, HSG A
* 1.240	96	Permeable Haul Road
162.240	71	Weighted Average
151.700		93.50% Pervious Area
10.540		6.50% Impervious Area

Tc (min)	Length (feet)	Slope (ft/ft)	Velocity (ft/sec)	Capacity (cfs)	Description
41.4	100	0.0028	0.04		Sheet Flow, A-B Grass: Dense n= 0.240 P2= 1.83"
47.6	2,161	0.0117	0.76		Shallow Concentrated Flow, B-C Short Grass Pasture Kv= 7.0 fps
1.2	69	0.0344	0.93		Shallow Concentrated Flow, C-D Woodland Kv= 5.0 fps
90.2	2,330	Total			

Summary for Reach DP1:

[40] Hint: Not Described (Outflow=Inflow)

Inflow Area = 162.240 ac, 6.50% Impervious, Inflow Depth = 1.71" for 100-Year event
Inflow = 103.89 cfs @ 13.12 hrs, Volume= 23.123 af
Outflow = 103.89 cfs @ 13.12 hrs, Volume= 23.123 af, Atten= 0%, Lag= 0.0 min

Routing by Stor-Ind+Trans method, Time Span= 0.00-72.00 hrs, dt= 0.01 hrs

Leatherleaf Solar, LLC
7501 Ivison Road
Town of Byron, New York

Appendix H: Post-Construction Inspection & Maintenance

Post Construction Inspection and Maintenance Site Checklist

1. Steep Slopes (any slope 3:1 or steeper) (Frequency: Annual)

	Yes	No	NA
a. Vegetation and ground cover adequate.	<input type="checkbox"/>	<input type="checkbox"/>	<input type="checkbox"/>
i. Minimum 80% ground cover. <i>Maintenance: Topsoil, rake and seed bare areas. Remove any dead or dying plants and decaying plant material. Replace dead and dying plants.</i>	<input type="checkbox"/>	<input type="checkbox"/>	<input type="checkbox"/>
ii. Excessively tall grass (greater than 6" in height) <i>Maintenance: Mow slopes 3:1 or flatter to have a grass height of 4" to 6". Increase mowing frequency as necessary. Steep slopes planted with meadow mix as shown on the approved plans do not have to be mowed.</i>	<input type="checkbox"/>	<input type="checkbox"/>	<input type="checkbox"/>
iii. Unauthorized plants. <i>Maintenance: Remove any unauthorized plants, including roots. Do not use herbicides. Topsoil, rake and seed the area disturbed by their removal.</i>	<input type="checkbox"/>	<input type="checkbox"/>	<input type="checkbox"/>
b. Slope erosion.	<input type="checkbox"/>	<input type="checkbox"/>	<input type="checkbox"/>
i. Small bare areas (min. 50 square feet). <i>Maintenance: Topsoil, rake and seed bare areas.</i>	<input type="checkbox"/>	<input type="checkbox"/>	<input type="checkbox"/>
ii. Ruts less than 12" wide. <i>Maintenance: Prior to making any repairs, identify the source of erosion and correct. Protect the slopes prior to any work occurring. Backfill ruts and compact soil. Topsoil, rake and seed bare areas. Alternatively, hydroseeding can be used to seed the slope.</i>	<input type="checkbox"/>	<input type="checkbox"/>	<input type="checkbox"/>
iii. Ruts greater than 12" wide. <i>Maintenance: Prior to making any repairs, identify the source of erosion and correct. Protect the slopes prior to any work occurring. Re-grade, backfill ruts and compact soil. Install erosion control mats on slopes 3:1 or steeper to protect the re-graded slope. Topsoil, rake and seed bare areas. Inspect on a weekly basis until 80% ground cover is achieved. Alternatively, hydroseeding can be used to seed the slope.</i>	<input type="checkbox"/>	<input type="checkbox"/>	<input type="checkbox"/>
c. Uneven settling	<input type="checkbox"/>	<input type="checkbox"/>	<input type="checkbox"/>
<i>Maintenance: Visually inspect for uneven settling. Classify the settling based upon the categories below.</i>			
i. Greater than 0" but less than 2" of settling. <i>Maintenance: No immediate action required. Re-inspect in 6 months.</i>	<input type="checkbox"/>	<input type="checkbox"/>	<input type="checkbox"/>
ii. Greater than 2" but less than 4" of settling. <i>Maintenance: Immediately repair. Re-grade and compact the soil. Topsoil, rake and seed the area. Re-inspect in 6 months.</i>	<input type="checkbox"/>	<input type="checkbox"/>	<input type="checkbox"/>

- | | Yes | No | NA |
|---|--------------------------|--------------------------|--------------------------|
| iii. Greater than 4" of settling.
<i>Maintenance: Immediately stabilize the area and consult a NYS Licensed Professional Engineer within 2 weeks before making any additional repairs.</i> | <input type="checkbox"/> | <input type="checkbox"/> | <input type="checkbox"/> |

2. Swales

(Frequency: Annual)

- | | Yes | No | NA |
|---|--------------------------|--------------------------|--------------------------|
| a. Inflow Points | <input type="checkbox"/> | <input type="checkbox"/> | <input type="checkbox"/> |
| i. Vegetation and ground cover adequate.
<i>Maintenance: Reseed bare areas. Remove any unauthorized plants or any nuisance weeds and vegetation, including their roots. Do not use any herbicides. Topsoil, rake and seed the disturbed area by their removal.</i> | <input type="checkbox"/> | <input type="checkbox"/> | <input type="checkbox"/> |
| ii. Free from erosion/undercutting.
<i>Maintenance: Immediately stabilize and repair any areas where erosion around has occurred. Rake and seed the area. Seed mixture shall meet the seed mixture requirements specified on the approved plans.</i> | <input type="checkbox"/> | <input type="checkbox"/> | <input type="checkbox"/> |
| iii. Rip rap in good condition.
<i>Maintenance: Replace stone, as necessary.</i> | <input type="checkbox"/> | <input type="checkbox"/> | <input type="checkbox"/> |
| iv. No evidence of sediment buildup.
<i>Maintenance: Remove and properly dispose of any accumulated sediment when the depth is 20% of swale design depth.</i> | <input type="checkbox"/> | <input type="checkbox"/> | <input type="checkbox"/> |
| b. Check Dams | <input type="checkbox"/> | <input type="checkbox"/> | <input type="checkbox"/> |
| i. No evidence of sediment buildup.
<i>Maintenance: Remove accumulated sediment behind dams when sediment depth is one-third the dam height.</i> | <input type="checkbox"/> | <input type="checkbox"/> | <input type="checkbox"/> |
| ii. Stone in good condition.
<i>Maintenance: Replace stone, as necessary.</i> | <input type="checkbox"/> | <input type="checkbox"/> | <input type="checkbox"/> |
| iii. No evidence of erosion
<i>Maintenance: Immediately stabilize and repair any areas where erosion has occurred. Replace stone, as necessary. Topsoil, rake and reseed area.</i> | <input type="checkbox"/> | <input type="checkbox"/> | <input type="checkbox"/> |
| c. Energy Dissipaters | <input type="checkbox"/> | <input type="checkbox"/> | <input type="checkbox"/> |
| i. No evidence of sediment buildup.
<i>Maintenance: Remove and properly dispose of any accumulated sediment when half of the void space is filled.</i> | <input type="checkbox"/> | <input type="checkbox"/> | <input type="checkbox"/> |
| ii. Rip rap in good condition.
<i>Maintenance: Replace stone, as necessary.</i> | <input type="checkbox"/> | <input type="checkbox"/> | <input type="checkbox"/> |
| iii. No evidence of erosion.
<i>Maintenance: Immediately stabilize and repair any areas where erosion has occurred. Replace stone, as necessary. Topsoil, rake and reseed.</i> | <input type="checkbox"/> | <input type="checkbox"/> | <input type="checkbox"/> |

3. Culverts

(Frequency: Annual)

	Yes	No	NA
a. Headwalls or End sections	<input type="checkbox"/>	<input type="checkbox"/>	<input type="checkbox"/>
i. In good condition, no need for repairs.	<input type="checkbox"/>	<input type="checkbox"/>	<input type="checkbox"/>
a. Cracks or displacement. <i>Maintenance: Repair any minor cracks. If minor displacement is observed, re-inspect in 6 months. Replace structure if major cracks or significant displacement is observed.</i>	<input type="checkbox"/>	<input type="checkbox"/>	<input type="checkbox"/>
b. Minor spalling (<1"). <i>Maintenance: Repair any minor spalling.</i>	<input type="checkbox"/>	<input type="checkbox"/>	<input type="checkbox"/>
c. Major spalling (rebars exposed). <i>Maintenance: Replace structure.</i>	<input type="checkbox"/>	<input type="checkbox"/>	<input type="checkbox"/>
ii. Clear of sediment. <i>Maintenance: Remove and properly dispose of any accumulated sediment.</i>	<input type="checkbox"/>	<input type="checkbox"/>	<input type="checkbox"/>
iii. Clear of debris and trash. <i>Maintenance: Remove and properly dispose of any debris and trash.</i>	<input type="checkbox"/>	<input type="checkbox"/>	<input type="checkbox"/>
b. Rip rap in good condition. <i>Maintenance: Replace stone, as necessary.</i>	<input type="checkbox"/>	<input type="checkbox"/>	<input type="checkbox"/>
c. Pipes free from damage, corrosion, and sediment. <i>Maintenance: Immediately repair any damaged pipes. If pipes are severely damaged and cannot be repaired, replace the pipes. Remove and properly dispose of any sediment.</i>	<input type="checkbox"/>	<input type="checkbox"/>	<input type="checkbox"/>

Notes:

1. The site must be returned to the approved conditions when any repairs are made.
2. Unauthorized plants are any plants that are growing or have been installed that are not any of the plants shown on the approved plans.
3. All seed mixtures shall meet the seed mixture requirements specified on the approved plans.
4. Replace any dead or dying plants with plants specified in the planting schedule shown on the approved plans.

Comments:

Actions to be taken:

Leatherleaf Solar, LLC
7501 Ivison Road
Town of Byron, New York

Appendix I: NYSDEC Permeable Haul Road Design

NYS DEC Pervious Haul Road Design

This summary explains the design methodology and rationale behind the Pervious Haul Road design. The proposed road design is shown in the attached detail. In layman's terms it can be described as clean, uncompacted stone not unlike railroad ballast installed on a geotextile.

Structurally, the design relies on the Giroud-Han method (GH Method)¹ for aggregate road design. We used the GH Method for typical representative soil conditions and loading conditions with the following design inputs:

Subgrade CBR = 1.60 (represents soaked clay)

Axle Load = 40 kips²

Road CBR = 20

ESAL = 10,000 (factor of safety =2)

Allowable rut depth = 3 inches

Using the GH Method implementation from Mirafi-Tencate, we find that the required clean stone application is 8" thick using Tencate RS380i geotextile. For the stone itself, we propose a #2 clean stone. This is a relatively common material in New York, and is frequently used for stabilized construction entrances.

Where a fill wedge is required, the wedge should be installed and compacted to about 80% MDD. This corresponds to the approximate native soil compaction level. To avoid over compaction of the fill wedge soil after installation, low ground pressure tracked equipment may be necessary for installation. It is important to note that in many of CCR's sites, that the native level of compaction could be a bit higher than 80% MDD due to high clay content. Native soil for the fill wedge is preferred to using clean stone.

The proposed ESAL has been computed based on standard anticipated trip generation. O&M assumes that the project will be in service for a full 25 years. It is also assumed that the Decommissioning portion of the project's life cycle will generate the same amount of traffic as the construction stage.

¹ Giroud, JP and Han, J, "Design Method for Geogrid-Reinforced Unpaved Roads, Parts I and II.", ASCE Journal of Geotechnical and Geoenvironmental Engineering, August 2004, pp 775-797.

² Corresponds to maximum single axle loading per HS-25. Exceeds single axle loading for a fire apparatus per NY Vehicles and Traffic Law §385[17-b]. It is important to note that the single axle loading for a typical truck is 18 kip.

Stage	Vehicle Class	Pavement Factor	Weekly trips	Project Time	ESAL
Construction	Multi-unit truck	1.3	10	16	416
Construction	Single Unit truck	0.6	10	16	192
Construction	Passenger Car	0.01	400	16	128
O&M	Landscaper Truck	0.6	2	1300	3120
Decom	Multi-unit truck	1.3	10	16	416
Decom	Single Unit truck	0.6	10	16	192
Decom	Passenger Car	0.01	400	16	128
				Total Project ESAL	4592

Attachments:

1. Pervious Haul Road Detail
2. TenCate Geosynthetic Cutsheet
3. TenCate Design Analysis (GH Method)
4. NYSDEC Central Section Correspondence
5. NYSDEC Region 3 Correspondence

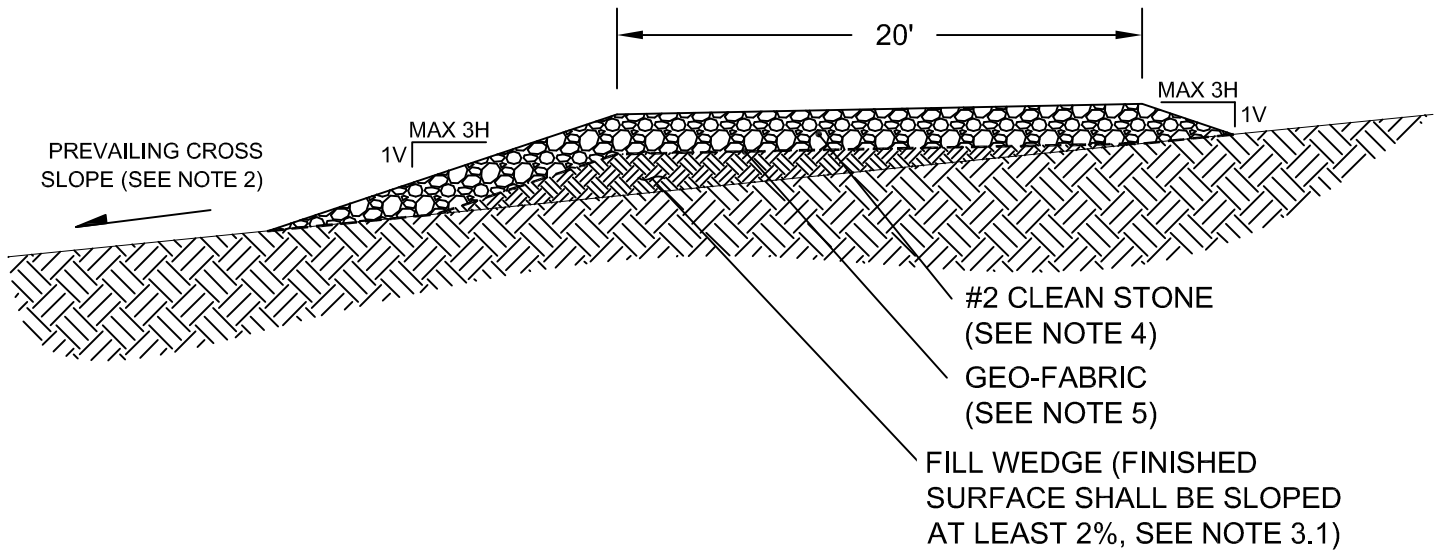

NOTES:

1. THIS HAUL ROAD DETAIL IS LIMITED TO CONSTRUCTION AND OCCASIONAL MAINTENANCE TRAFFIC FOR RENEWABLE ENERGY PROJECTS IN NEW YORK STATE.
2. DESIGN LIMITATIONS:
 - 2.1. ESAL = 10,000
 - 2.2. CLEAN STONE SHALL BE MINIMUM 8 INCHES THICK.
 - 2.3. CROSS SLOPE SHALL NOT EXCEED 5%, RUNNING SLOPE SHALL NOT EXCEED 10%.
3. CONSTRUCTION SPECIFICATION:
 - 3.1. IN AREAS OF NO EARTHWORK, THE ROAD SHALL BE INSTALLED ON UNCOMPACTED SURFACE GRADE. ALIGNMENT MAY BE MOWED BUT NOT GRUBBED. WHERE REQUIRED, A NATIVE SOIL FEATHER WEDGE, COMPACTED 80% MDD MAY BE INSTALLED. FEATHER WEDGE SHALL BE SLOPED AT 2% MINIMUM TO SHED WATER.
 - 3.2. IN AREAS WITH BULK EARTHWORK, THE ROAD SHALL BE INSTALLED ON FINAL GRADE.
 - 3.3. THE HAUL ROAD SHALL NOT BE CONSTRUCTED ON NYSDOT SUBBASE MATERIAL OR EQUIVALENT.
4. THE HAUL ROAD SHALL BE CONSTRUCTED OF #2 (2 1/2") CLEAN STONE. STONE MAY BE DEPOSITED AND SPREAD BY A TRACKED VEHICLE.
5. GEOFABRIC SHALL BE MIFARI TENCATE RS 380i (OR APPROVED EQUAL)
6. CONSTRUCTION AND MAINTENANCE LIMITATIONS:
 - 6.1. THE #2 CLEAN STONE SHALL NOT BE COMPACTED WITH A VIBRATORY ROLLER, PLATE COMPACTOR, OR OTHER MEANS.
 - 6.2. TOP DRESS ONLY WITH #2 CLEAN STONE.
 - 6.3. DO NOT OIL OR WATER BIND, SEALCOAT, OR CHOKE STONE.
 - 6.4. DO NOT OVERLAY WITH CONCRETE, ASPHALT PAVEMENT, OR ANY MATERIAL THAT WILL CREATE AN IMPERVIOUS SURFACE.

NYSDEC PERVIOUS HAUL ROAD CROSS SECTION

(NTS, 11.07.2017)

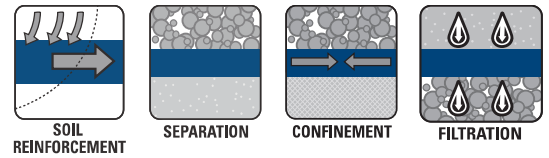

Mirafi® RSi - Series Woven Geosynthetics for Soil Stabilization and Base Course Reinforcement Applications

TenCate develops and produces materials that deliver increased performance, reduce costs and measurable results to provide advanced solutions utilizing patent pending Mirafi® RSi geosynthetics that make a difference.

The Difference Mirafi® RSi-Series Woven Integrated* Geosynthetics Make:

- Modulus. Separation. Confinement. Water flow. Orange product identification. **Superior integration***.
- Reinforcement Strength. Higher tensile modulus properties than the leading stabilization products.
- Separation and Filtration. Unique double layer construction provides a wide range of pore sizes for an excellent separation factor, superior filtration and flow characteristics of a fine to coarse sand layer.
- Soil and Base Course Interaction. Excellent soil and base course confinement resulting in greater load distribution.
- Durability. Robust damage resistance for moderate to severe stress installations.
- Roll Sizes. Mirafi® RSi-Series geosynthetics come in several roll sizes to fit project requirements.

- Seams. Panels can be seamed in the factory or field, providing cross-roll direction strength to facilitate efficient installation.

APPLICATIONS

When superior performance, flexibility and versatility are necessary, Mirafi® RSi-Series geosynthetics make the difference for varying application needs including: base course reinforcement and subgrade stabilization for road, runway and railway construction; embankment stabilization on soft foundations; reinforcement for mechanically stabilized earth (MSE) structures; liner support, voids bridging, reinforcement over soft hazardous pond closures and other environmental market applications.

INSTALLATION GUIDELINES**

Geosynthetic Placement
Place the geosynthetic directly on prepared surface. It is advisable to leave vegetative cover such as grass and weeds in place to provide a support matting for construction activities. The geosynthetic should be deployed flat and tight with no wrinkles or folds. The rolls should be oriented as shown on plans to ensure the principal strength direction of the material is placed in the correct orientation. Adjacent rolls should be overlapped or seamed as a function of subgrade strength (CBR). Prior to fill placement, Mirafi® RSi-Series geosynthetics should be held in place using suitable means such as pins, soil, staples or sandbags to limit movement during fill placement.



Mirafi® RSi-Series Woven Geosynthetic

Fill Placement

Fill should be placed directly over Mirafi® RSi geosynthetic in 8in (20cm) to 12in (30cm) loose lifts. For very weak subgrades, 18in (45cm) lifts or thicker lifts may be required to stabilize the subgrade, as directed by the engineer. Most rubber-tired vehicles can be driven at slow speeds, less than 10mph (16km/h) and in straight paths over the exposed geosynthetic without causing damage. Sudden braking and sharp turning should be avoided. Tracked construction equipment should not be operated directly upon the geosynthetic. A minimum fill soil thickness of 6in (15cm) is required prior to operation of tracked vehicles over the geosynthetic. Turning of tracked vehicles should be kept to a minimum to prevent tracks from displacing the fill and damaging the geotextile.

** These guidelines serve as a general basis for installation. Detailed instructions are available from your TenCate representative.

Visit www.mirafi.com for a demonstration video

Breakthrough Research: TenCate Mirafi® Geosynthetic Outperforms Others in Independent Full-Scale Study.



Protective & Outdoor Fabrics
Aerospace Composites
Armour Composites

Geosynthetics
Industrial Fabrics
Synthetic Grass

*Integration refers to the overall set of described characteristics based on a review of technical specifications for comparable products published by their respective manufacturers. Individual characteristics of these products vary and may meet, exceed, or fall below one or more of the above described individual characteristics.

Mirafi® RSi - Series Woven Geosynthetics

for Soil Stabilization and Base Course Reinforcement Applications

Mechanical Properties	Test Method	Unit	RS280 ⁱ	RS380 ⁱ	RS580 ⁱ	
Typical Roll Value/Minimum Average Roll Value						
Tensile Strength @ 2% strain (MD)	ASTM D4595	lbs/ft (kN/m)	840 (12.3)/600 (8.8)	720 (10.5)/600 (8.8)	540 (7.9)/480 (7.0)	
Tensile Strength @ 2% strain (CD)	ASTM D4595	lbs/ft (kN/m)	960 (14.0)/600 (8.8)	1200 (17.5)/1020 (14.9)	2160 (31.5)/1800 (26.3)	
Tensile Strength @ 5% strain (MD)	ASTM D4595	lbs/ft (kN/m)	1980 (28.9)/1620 (23.6)	2100 (30.6)/1800 (26.3)	1560 (22.8)/1440 (21.0)	
Tensile Strength @ 5% strain (CD)	ASTM D4595	lbs/ft (kN/m)	2100 (30.6)/1620 (23.6)	2580 (37.6)/2256 (32.9)	4920 (71.8)/4380 (69.3)	
Flow Rate	ASTM D4491	gal/min/ft ² (l/min/m ²)	70 ¹ (2852)	75 ¹ (3056)	75 ¹ (3056)	
Permittivity	ASTM D4491	sec ⁻¹	0.9 ¹	0.9 ¹	1.0 ¹	
Pore Size O ₅₀	ASTM D676	microns	175	185	192	
Pore Size O ₈₅	ASTM D6767	microns	273	365	337	
Interaction Coefficient ²	ASTM D6706	---	0.89 ²	0.89 ²	0.9 ²	
Index Properties						
Apparent Opening Size (AOS)	ASTM D4751	U.S. Sieve (mm)	40 (0.425)	40 (0.425)	40 (0.425)	
Factory Seam Strength	ASTM D4884	lbs/ft (kN/m)	2400 (35.0) ¹	2700 (39.4) ¹	3000 (43.8) ¹	
UV Resistance (at 500 hours)	ASTM D4355	% strength retained	90 ¹	90 ¹	90 ¹	
¹ Minimum Roll Value						
² Interaction Coefficient value is for sand or gravel based on testing by SGI Testing Services.						
Physical Properties			Unit	RS280ⁱ	RS380ⁱ	RS580ⁱ
Roll Width		ft (m)	15 (4.6)	17 (5.2)	15 (4.6)	17 (5.2)
Roll Length		ft (m)	300 (91)	300 (91)	300 (91)	300 (91)
Roll Area		yd ² (m ²)	500 (419)	567 (474)	500 (419)	567 (474)

Mirafi® RSi-Series Woven Geosynthetics

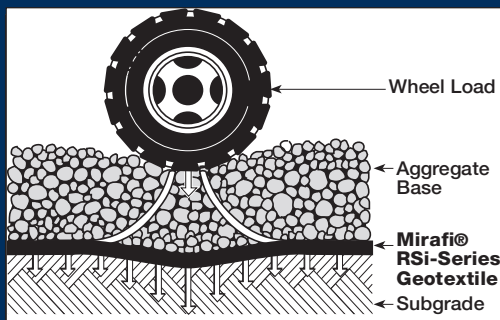

Subgrade Load Distribution

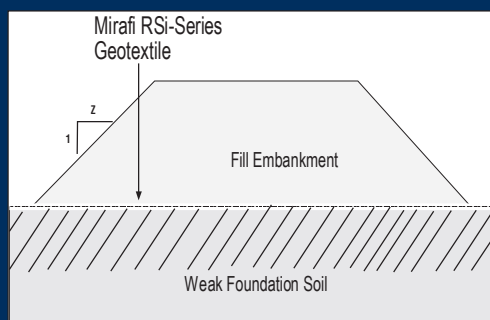

Embankments Over Soft Soils

TenCate Geosynthetics Americas assumes no liability for the accuracy or completeness of this information or for the ultimate use by the purchaser. TenCate Geosynthetics Americas disclaims any and all express, implied, or statutory standards, warranties or guarantees, including without limitation any implied warranty as to merchantability or fitness for a particular purpose or arising from a course of dealing or usage of trade as to any equipment, materials, or information furnished herewith. This document should not be construed as engineering advice.

Mirafi® is a registered trademark of Nicolon Corporation.

© 2016 Nicolon Corporation. All Rights Reserved.

PDS.RSI0916

365 South Holland Drive Pendergrass, GA 30567
 Tel 800 685 9990 Tel 706 693 2226
 Fax 706 693 4400 www.mirafi.com



TENCATE
 materials that make a difference



TenCate Geosynthetics
North America

Unpaved Analysis Report

Project Name: New York Haul Road

Clay Soils (HS-25)

Report Date: 10/26/2017

Report Run By: Joe Schaffer

Traffic Data			
Axle Load - P (lbs)	40,000	Axle Passes - N	10000
Tire Pressure - p (psi)	80	Rut Depth - s (in)	3.0
Subgrade Data			
SG Strength Value	1.60	SG Strength Parameter	CBR, soaked (ASTM D1883) (AASHTO93)
		Converted SG Strength - CBR(%)	1.60
Gravel / Aggregate Data			
CBR of Roadway Aggregate	20.0	Factor of Safety - FS	1.2

Aggregate Thickness

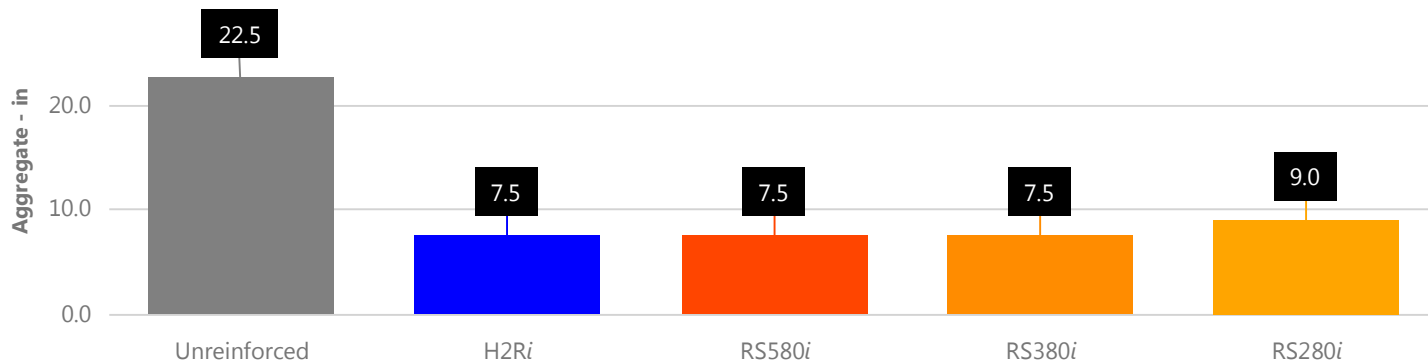

Mirafi® Products
Minimum thickness recommendations shown in the graph above.

Roadway Thickness Analysis Results				
	h ₀ (in)	SN	Savings	BCR
H ₂ Ri	7.5	1.62	67 %	3.0
RS580i	7.5	1.62	67 %	3.0
RS380i	7.5	1.62	67 %	3.0
RS280i	9.0	1.62	60 %	2.5
Unreinforced	22.5	1.62		

CSI specifications: <http://www.tencate.com/amer/geosynthetics/knowledge-library/csi-specs/default.aspx>

Comparative Cost Analysis				Total Estimated Quantity (yd ²): 20,000					
	Unit Cost (\$)		Depth of Gravel (in)	Excavation and Removal		Section Cost (yd ²)	Project Cost	Project Savings	Cost Savings
				Cost (yd ² -in)	Cost (yd ²)				
H ₂ Ri	5.00	per yd ²	8	0.25	\$1.88	\$11.75 *	\$272,600	\$244,800	47 %
RS580i	4.00	per yd ²	8	0.25	\$1.88	\$10.75 *	\$252,600	\$264,800	51 %
RS380i	3.25	per yd ²	8	0.25	\$1.88	\$10.00 *	\$237,600	\$279,800	54 %
RS280i	2.25	per yd ²	9	0.25	\$2.25	\$10.35 *	\$252,000	\$265,400	51 %
Unreinforced	18.00	per ton	22	0.25	\$5.62	\$20.25	\$517,400		
*RSi-Series & H ₂ Ri anticipated cost estimate includes aggregate costs, purchase price, installation, overlap, and waste									

The information herein is accurate to the best of our knowledge. TenCate Geosynthetics North America assumes no liability for the accuracy or completeness of this information or for the ultimate use by the purchaser. TENCATE GEOSYNTHETICS NORTH AMERICA DISCLAIMS ANY AND ALL EXPRESS, IMPLIED, OR STATUTORY STANDARDS, WARRANTIES, OR GUARANTEES, INCLUDING WITHOUT LIMITATION ANY IMPLIED WARRANTY OF MERCHANTABILITY OR FITNESS FOR A PARTICULAR PURPOSE arising from a course of dealing or usage of trade as to any equipment, materials, or information furnished herewith. This document should not be construed as engineering advice. Users should satisfy themselves through independent investigation that these materials might be used safely. No warranty or guarantee, expressed or implied, is made regarding the performance of any product, since the manner of use and handling are beyond our control. Any and all design related to a product will be the responsibility of the project engineer and/or registered engineer of record.

365 South Holland Drive
Pendergrass, GA 30567

Tel 706 693 2226
Tel 888 795 0808

Fax 706 693 4400
www.mirafi.com



Joe Schaffer

From: Gasper, David J (DEC) <david.gasper@dec.ny.gov>
Sent: Wednesday, July 05, 2017 12:42 PM
To: Joe Schaffer
Subject: RE: Pervious Haul Road

Joe,

I reviewed the updated Haul Road Cross Section. Based on the changes made, the Department would consider the proposed section to be pervious. Therefore, the SWPPP for this portion of the project (haul road) would typically just need to address erosion and sediment controls.

For specific project reviews, I would recommend that you meet with or discuss this cross section with our Regional Office stormwater staff early on in the planning stages. They will contact me if they have any questions on the cross section.

If you have a specific project in the planning, you can contact me to get the Regional Office staff person you would be working with.

From: Joe Schaffer [mailto:joe.schaffer@ccrenew.com]
Sent: Friday, June 30, 2017 5:00 PM
To: Gasper, David J (DEC) <david.gasper@dec.ny.gov>
Subject: Re: Pervious Haul Road

ATTENTION: This email came from an external source. Do not open attachments or click on links from unknown senders or unexpected emails.

Hi Dave - thanks for your quick and thorough review.

I worked your recommended changes and also advanced the structural design a bit. I finally settled on a uniform thickness for the clean stone - this will be easier to build and won't lead to confusion over insitu soaked CBR.

Thanks and have a great weekend!! --Joe

From: Gasper, David J (DEC) <david.gasper@dec.ny.gov>
Sent: Friday, June 30, 2017 9:50:14 AM
To: Joe Schaffer
Subject: RE: Pervious Haul Road

Joe,

One additional question. Your e-mail mentions "pavement thickness". Did you mean the thickness the "clean stone"?

From: Gasper, David J (DEC)
Sent: Friday, June 30, 2017 9:47 AM
To: 'Joe Schaffer' <joe.schaffer@ccrenew.com>
Subject: RE: Pervious Haul Road

Joe,

I reviewed the Haul Road sectional view and Notes and generated the following comments:

Sectional View

- Change “compacted #2 clean stone (see note 2)” to “#2 clean stone (see note 2)”.

Notes

- Notes 2.2 and 2.3: remove all references to gravel and replace with “clean stone”
- Note 3.1 (second sentence): revise to read as follows “Where required, a native soil feather wedge, compacted to the degree of the native/insitu soil, may be installed.”
- Note 3.2: Add “The haul road shall not be constructed on NYS DOT subbase material or equivalent.”
- Note 3.3: Change first sentence to “The haul road shall be constructed of #2 clean stone (2 ½”).”
- Note 4.1: Add “The #2 clean stone...” and remove “intentionally”.
- Note 4.4: Add “asphalt pavement” after concrete

Please let me know if you have any questions.

From: Joe Schaffer [<mailto:joe.schaffer@ccrenew.com>]
Sent: Thursday, June 29, 2017 4:44 PM
To: Gasper, David J (DEC) <david.gasper@dec.ny.gov>
Subject: RE: Pervious Haul Road

ATTENTION: This email came from an external source. Do not open attachments or click on links from unknown senders or unexpected emails.

Hi Dave –

Please find attached a preliminary detail for our proposed haul road. I am working with the manufacturer (Mirafi) to confirm the pavement thickness numbers and fabric types. What we decide on will follow the theme as presented herein.

Please let me know if this will be acceptable as a “pervious road”.

Thanks!!! --Joe

From: Gasper, David J (DEC) [<mailto:david.gasper@dec.ny.gov>]
Sent: Tuesday, June 27, 2017 12:33 PM
To: Joe Schaffer <joe.schaffer@ccrenew.com>
Subject: RE: Pervious Haul Road

Joe,

As discussed in our telephone conversation, the DEC does consider the placement of a clean, washed stone (not gravel) over insitu soil as a permeable surface that typically would not need to address post-construction controls. Please note that the clean, washed stone cannot be placed over NYS DOT subbase material or equivalent. The DEC considers that type of surface to be impervious and would require post-construction controls to manage the runoff.

If the designer proposes clean, washed stone; they should make sure that the road can adequately support the expected vehicular traffic (i.e. fire trucks, other rubber tire vehicles) so that the road does not have to be resurfaced with a pavement or subbase material in the future. As discussed above, the subbase (NYS DOT or equivalent) surface would be considered an impervious surface (same for the asphalt) that would require post-construction controls to manage runoff from the road.

I would also recommend that you review the definition of impervious cover in Chapter 4 and the Glossary of the NYS Stormwater Management Design Manual. Please let me know if you have any questions.

From: Joe Schaffer [<mailto:joe.schaffer@ccrenew.com>]

Sent: Tuesday, June 27, 2017 12:19 PM

To: Gasper, David J (DEC) <david.gasper@dec.ny.gov>

Subject: Pervious Haul Road

ATTENTION: This email came from an external source. Do not open attachments or click on links from unknown senders or unexpected emails.

Hi Dave -

Great chatting with you today! Can you send me your boilerplate response on the pervious haul road question?

Thanks!!

Joseph F. Schaffer, PE, PP, LEED-AP

Senior Civil Engineer

Cypress Creek Renewables

601-A West Main Street | Carrboro, NC 27510

(home office) 24 Henry Street | Metuchen, NJ 08840

(d) 919-651-3414 | joe.schaffer@ccrenew.com

NYSDEC Region 3 Review and Response

From: Mike Finan <mfinan@langan.com>
Sent: Monday, August 7, 2017 8:31:55 PM
To: Joe Schaffer; Harrison Netz
Cc: Crystal Eggers
Subject: Fwd: Haul Road

Hi Joe

Per our conversation, please see the below correspondence with NYSDEC on the haul road. This is exactly how we have been addressing the haul road in our SWPPP's.

Michael Finan
Associate

LANGAN

Mobile: 914.523.4496

Begin forwarded message:

From: Christina Zolezi <czolezi@langan.com<<mailto:czolezi@langan.com>>>
Date: August 7, 2017 at 3:00:12 PM EDT
To: Mike Finan <mfinan@langan.com<<mailto:mfinan@langan.com>>>
Subject: FW: Haul Road

Please see below.

Christina

Christina M. Zolezi, PE
Project Engineer
Direct: 914.323.7418
File Sharing Link<<http://clients.langan.com/FileSharing/default.aspx?shareCD=429022399>>

LANGAN

www.langan.com<<http://www.langan.com/>>

From: Browne, Natalie S (DEC) [<mailto:natalie.browne@dec.ny.gov>]
Sent: Monday, August 07, 2017 2:59 PM
To: Christina Zolezi
Subject: Haul Road

Christina,

Assuming the surface of the road is uniform size stone with no fines on top of native soils, then it would be considered pervious for water quality calculations. You would use TR-55 to determine if you need to treat for quantity using the curve number that corresponds to the onsite soil group type.

-Natalie

From: Christina Zolezi [<mailto:czolezi@langan.com>]
Sent: Monday, August 07, 2017 12:27 PM
To: Browne, Natalie S (DEC) <natalie.browne@dec.ny.gov<<mailto:natalie.browne@dec.ny.gov>>>
Subject: permeable haul road

ATTENTION: This email came from an external source. Do not open attachments or click on links from unknown senders or unexpected emails.

Hi Natalie,
I just wanted to follow-up our phone call discussion regarding the permeable haul road with an email.

Based on our discussion, for the water quality calculations the permeable haul road is to be treated as a pervious surface. In the stormwater modeling, the pervious haul road is to be treated as gravel using the curve number that corresponds to the onsite soil group type.

Thanks.
Christina

Christina M. Zolezi, PE
Project Engineer
Direct: 914.323.7418
File Sharing Link<<http://clients.langan.com/FileSharing/default.aspx?shareCD=429022399>>

LANGAN
Phone: 914.323.7400 Fax: 914.323.7401
707 Westchester Avenue, Suite 304
White Plains, NY 10604-3102
www.langan.com<<http://www.langan.com/>>

EXHIBIT H-1. DECOMMISSIONING PLAN

EXHIBIT H-2. DECOMMISSIONING COST ESTIMATE

Leatherleaf Solar, LLC Decommissioning Plan

Prepared and Submitted by Leatherleaf Solar, LLC

Decommissioning will occur as a result of any of the following conditions:

1. The land lease expires or is terminated; or
2. The solar energy system the (“SES”) does not produce power for a period of 12 consecutive months

Leatherleaf Solar, LLC (the “Operator”) of the SES will do the following as a minimum to decommission the SES:

1. Remove all Operator-owned equipment, conduits, structures, and foundations to a depth of at least four feet below grade; and
2. Remove all fencing unless the owner of the leased real estate requests in writing for it to stay in place; and
3. Take the following steps to restore the land:
 - a. Grade to maintain existing drainage patterns at the time of decommissioning unless stated otherwise by the leading Authority Having Jurisdiction (AHJ) or in any governing decommissioning ordinance;
 - b. Reseed the land using local non-invasive grasses; and
 - c. Maintain the grass for a total of three months after the seeding.

All such removal and decommissioning shall occur within 12 months of any aforementioned decommissioning condition.

The Operator is responsible for decommissioning the SES.

The Operator will provide the Town of Byron Planning Board with an updated signed decommissioning plan within 30 days if the operator of the SES changes.

Any updates to this plan will be submitted to the Town of Byron Planning Board by the party responsible for decommissioning the SES.

Operator: Leatherleaf Solar, LL

Signature: 

Date: 3/22/2023

DocuSigned by:
536AA40AC84042D...



<i>Project:</i>	<i>Leatherleaf Solar, LLC</i>	<i>Engineer:</i>	<i>J. Farrell</i>
<i>Client:</i>	<i>CCR</i>	<i>Issue Date:</i>	<i>1/20/23</i>
<i>Location:</i>	<i>Byron, NY</i>	<i>Revision:</i>	<i>0</i>

OPINION OF PROBABLE COST - PV PLANT DECOMMISSIONING - SAT - 5 MWac

This opinion of probable costs is based on the engineer's experience in the design and construction of energy facilities and are subject to final engineering. This opinion is also based on our experience supervising the construction of PV plants and supervising the demolition of other non-PV facilities. The engineer accepts no liability for errors, omissions, or the accuracy and adequacy of this opinion. It is a violation of state law for any person, unless they are acting under direction of a licensed professional engineer to alter this document in any way. The engineer is unaware of a significant body of decommissioning PV plants with which to benchmark its opinion of cost. With the exception of the PV modules and inter-module wiring, none of the activities undertaken to disassemble a PV plant are unique to PV plants. Disassembly costs can be estimated similar to other types of facilities.

According to the Town of Byron Local Law #3, decommissioning will occur as a result of any of the following conditions: the land lease, if any, ends; the system does not produce power for 12 months; or the system is damaged and will not be repaired or replaced. The decommissioning plan is required to be completed within 1 year of notification from the Town. This opinion assumes the decommissioning activities to span approximately 3 months.

This opinion assumes a third-party contractor, experienced in the construction and decommissioning of PV facilities will lead the effort. The reported costs include labor, materials, taxes, insurance, transport costs, equipment rental, contractor's overhead, and contractor's profit. Labor costs have been estimated using regional labor rates and labor efficiencies from the Bureau of Labor Statistics. This opinion assumes union labor rates.

This opinion of cost has been split between plant disassembly and site restoration, which reflects the overall decommissioning process. The PV plant will first be disassembled, with all above and below grade components removed to a depth of 3 feet. This includes all buried cables, conduits, and foundations. Costs for disassembly are overall less than those for original assembly of the facility. While PV modules will need to be removed by hand, the racks, buried cables, and concrete can be removed by machine to increase efficiency. It is assumed that concrete, gravel, and fiber optic cable will be disposed off site.

It is expected that the entire site will be re-seeded with native grasses and vegetation. Planting of trees, shrubs, and other woody vegetation (re-forestation) or other beautification is not included in the costs. It is assumed that mulching and stabilization of seeded areas will only be required where gravel roads or concrete foundations were removed. As all cables will be direct buried, excavation to remove the cables will not be required, and the disturbance to those areas will be minimal. The remainder of site will already be vegetated and disassembly activities will not significantly disturb the vegetation. Seeding in those areas is included as a precautionary measure.

It is assumed that re-grading of the site to remove diversion dikes and retention ponds is not required. The earth-moving required to remove these features would likely trigger a NPDES (or state/local equivalent) permit, which would in turn require those same features to be installed to control stormwater on the site. In addition, it is assumed limited erosion and sediment control measure will be required for disassembly. These would have been put in place during the original construction, and would be required to remain in place and properly maintained for the project life.

Inflation in this estimate has been projected based on the Producer Price Indices for Final Demand Construction. PPI is a more appropriate measure than CPI as it is targeted to the specific commodity. Detailed assumptions and the total opinion of cost for decommissioning is provided on the next sheets.

<i>Project:</i>	<i>Leatherleaf Solar, LLC</i>	<i>Engineer:</i>	<i>J. Farrell</i>
<i>Client:</i>	<i>CCR</i>	<i>Issue Date:</i>	<i>1/20/23</i>
<i>Location:</i>	<i>Byron, NY</i>	<i>Revision:</i>	<i>0</i>

PV PLANT ANTICIPATED DISASSEMBLY METHODS	
ITEM	DISASSEMBLY METHOD
PV Modules	Hand Removal. Place modules face down on pallets, tape wire ends, tied down and transport via skid-steer to staging location. Assumed 5% breakage. 1200 modules/day, 6-person crews
Inverters	Removal by crane and transport via flat-bed to staging location. Assume no disassembly.
Transformers	Removal by crane and transport via flat-bed to staging location. Assume no disassembly. Oil removal performed by scrap facility.
Racking Frame	Stabilize w/ machine. Cut legs and lower to ground level. Cut cross beams to appropriate size and transport via dump truck to staging location.
Racking Posts	Remove via post-puller and transport via dump truck to staging location. Assumed 50% of posts to be disposed.
Racking Wiring	Disconnect PV connectors, cut cable ties, and remove wires from cable tray. Transport via dump truck to staging area.
Underground Cable	Excavate to cable depth at one end of trench. Use tractor or backhoe pull out all cables in common trench. Cables are direct buried so complete excavation of trenches is not required. Transport via dump truck to staging area.
Fence	Machine roll fence fabric. Remove posts via post-puller and transport via dump truck to staging location.
Concrete	Remove with excavator and jack hammer. Backfill and compact as needed. Transport via dump truck to staging area. Assumed offsite disposal.
Gravel	Remove with skid steer with sweeper. Transport via dump truck to staging area. Assumed offsite disposal.
Offsite Disposal	Assumed disposal at \$95/ton or \$45/CY including tipping fee.
Re-Seeding	Re-seed using an ATV-pulled drill seeder, at 5lbs bulk seed per acre of native grasses. Stabilize and mulch on areas where concrete or gravel was removed only.
Re-Grading	No bulk re-grading is included as this would alter site hydrology.
Erosion & Sediment Control	Install silt fence around project perimeter. Install tracking control at site entrance and replace once during disassembly. Remove at end of disassembly. We anticipate net soil disturbance is < 1 acre.

Project:	Leatherleaf Solar, LLC	Engineer:	J. Farrell
Client:	CCR	Issue Date:	1/20/23
Location:	Byron, NY	Revision:	0

OPINION OF PROBABLE COST - PV PLANT DECOMMISSIONING - 5 MW - ANNUAL INFLATION=1.3% - END OF LIFE: YEAR 40				
DISASSEMBLY & DISPOSAL				
ITEM	DESCRIPTION	QUANTITY	UNIT PRICE	TOTAL
1.0	PV Modules (560 W)	11,622	\$ 3.58	\$ 41,606.76
2.0	PV Inverter(s) (2.8 MVA)	2	\$ 2,079	\$ 4,158.00
3.0	PV Transformer(s) (2.8 MVA)	2	\$ 1,040	\$ 2,080.00
4.0	Not Used	0	-	-
5.0	Not Used	0	-	-
6.0	Not Used	0	-	-
7.0	Racking Frame (Single Axis)	149	\$ 284	\$ 42,316.00
8.0	Racking Posts	1,946	\$ 29	\$ 56,434.00
9.0	Tracker Motors	149	\$ 38	\$ 5,662.00
10.0	Racking Wiring	145,227 LF	\$ 0.15	\$ 21,784.05
11.0	Underground Cable (LV, MV, Comm)	20,000 LF	\$ 1.10	\$ 22,000.00
12.0	PV Plant Fence	5,987 LF	\$ 4.75	\$ 28,438.25
13.0	Interconnection Facilities	1 LS	\$ 11,739.00	\$ 11,739.00
14.0	Concrete	10 CY	\$ 156	\$ 1,560.00
15.0	Gravel	1,336 CY	\$ 58	\$ 77,488.00
16.0	Offsite Disposal by Volume	1,347 CY	\$ 45	\$ 60,615.00
17.0	Offsite Disposal by Weight	81.80 TON	\$ 95	\$ 7,771.00
18.0	General Conditions	5 MW	\$ 14,158	\$ 70,790.00
SUBTOTAL				\$ 454,442.06
SITE RESTORATION				
ITEM	DESCRIPTION	QUANTITY	UNIT PRICE	TOTAL
19.0	Re-Seeding	35 ACRES	\$ 198	\$ 6,930.00
20.0	Re-Grading	1 LS	\$ -	\$ -
21.0	Erosion and Sediment Control	1 LS	\$ 26,942	\$ 26,942.00
SUBTOTAL				\$ 33,872.00
TOTAL DISASSEMBLY, DISPOSAL, & SITE RESTORATION COST				\$ 488,314.06

Mott MacDonald



Scott Kibby, PE
Principal Geotechnical Engineer
(781) 636-4115

1/24/2023

Date

Scott
Kibby
P.E

Digitally signed by Scott Kibby
P.E
DN: cn=Scott Kibby P.E, c=US,
o=Mott MacDonald,
email=Scott.Kibby@mottmac.com
Reason: I am approving this
document
Location: Westwood MA
Date: 2023.01.24 15:56:46 -
05'00'

EXHIBIT I. NYSDAM GUIDELINES FOR SOLAR ENERGY PROJECTS

NEW YORK STATE DEPARTMENT OF AGRICULTURE AND MARKETS

Guidelines for Solar Energy Projects - Construction Mitigation for Agricultural Lands (Revision 10/18/2019)

The following are guidelines for mitigating construction impacts on agricultural land during the following stages of a solar energy project: Construction, Post-Construction Restoration, Monitoring and Remediation, and Decommissioning. These guidelines apply to project areas subject to ground disturbance¹ within agricultural lands including:

- Lands where agriculture use will continue or resume following the completion of construction (typically those lands outside of the developed project's security fence);
- Lands where the proposed solar development will be returning to agricultural use upon decommissioning, (typically those lands inside of the developed project's security fence);
- Applicable Area under review pursuant to Public Service Law Article 10 Siting of Major Electric Facilities.

The Project Company will incorporate these Guidelines into the development plans and applications for permitting and approval for solar projects that impact agricultural lands. If the Environmental Monitor, hereafter referred to as EM, determines that there is any conflict between these Guidelines and the requirements for project construction that arise out of the project permitting process, the Project Company and its EM, will notify the New York State Department of Agriculture and Markets (NYSDAM), Division of Land and Water Resources, and seek a reasonable alternative.

Environmental Monitor (EM)

The Project Company (or its contractor) shall hire or designate an EM to oversee the construction, restoration and follow-up monitoring in agricultural areas. The EM shall be an individual with a confident understanding of normal agriculture practices² (such as cultivation, crop rotation, nutrient management, drainage (subsurface and/or surface), chemical application, agricultural equipment operation, fencing, soils, plant identification, etc.) and able to identify how the project may affect the site and the applicable agricultural practices. The EM should also have experience with or understanding of the use of a soil penetrometer for compaction testing and record keeping. The EM may serve dual inspection roles associated with other Project permits and/or construction duties, if the agricultural workload allows. The EM should be available to provide site-specific agricultural information as necessary for project development through field review and direct contact with both the affected farm operators and NYSDAM. The EM should maintain regular contact with appropriate onsite project construction supervision and inspectors throughout the construction phase. The EM should maintain regular contact with the affected farm operator(s) concerning agricultural land impacted, management matters pertinent to the agricultural operations and the site-specific implementation of agricultural resource mitigation measures. The EM will serve as the agricultural point of contact.

¹Ground Disturbance is defined as an activity that contributes to measurable soil compaction, alters the soil profile or removes vegetative cover. Construction activities that utilize low ground pressure vehicles that do not result in a visible rut that alters soil compaction, is not considered a Ground Disturbance. Soil compaction should be tested using an appropriate soil penetrometer or other soil compaction measuring device. The soil compaction test results within the affected area will be compared with those of the adjacent unaffected portion of the agricultural area.

² An EM is not expected to have knowledge regarding all of the listed agricultural practices, but rather a general understanding such that the EM is able to perform the EM function.

1. For projects involving less than 50 acres of agricultural land within the limits of disturbance (LOD),³ the EM shall be available for consultation and/or on-site whenever construction or restoration work that causes Ground Disturbance is occurring on agricultural land.
2. For projects involving 50 acres or more of agricultural land within the (LOD) (including projects involving the same parent company whether phased or contiguous projects), the EM shall be on site whenever construction or restoration work requiring or involving Ground Disturbance is occurring on agricultural land and shall notify NYSDAM of Project activity. The purpose of the agency coordination would be to assure that the mitigation measures of these guidelines are being met to the fullest extent practicable. The Project Company and the NYSDAM will agree to schedule inspections in a manner that avoids delay in the work. NYSDAM requires the opportunity to review and will approve the proposed EM based on qualifications or capacities.

Construction Requirements

- Before any topsoil is stripped, representative soil samples should be obtained from the areas to be disturbed. The soil sampling should be consistent with Cornell University's soil testing guidelines, and samples should be submitted to a laboratory for testing PH, percent organic material, cation exchange capacity, Phosphorus/Phosphate (P), and Potassium/Potash (K). The results are to establish a benchmark that the soil's PH, Nitrogen (N), Phosphorus/Phosphate (P), and Potassium/Potash (K) are to be measured against upon restoration. If soil sampling is not performed, fertilizer and lime application recommendations for disturbed areas can be found at https://www.agriculture.ny.gov/ap/agservices/Fertilizer_Lime_and_Seeding_Recommendations.pdf.
- Stripped topsoil should be stockpiled from work areas (e.g. parking areas, electric conductor trenches, along access roads, equipment pads) and kept separate from other excavated material (rock and/or sub-soil) until the completion of the facility for final restoration. For proper topsoil segregation, at least 25 feet of additional temporary workspace (ATWS) may be needed along "open-cut" underground utility trenches. All topsoil will be stockpiled as close as is reasonably practical to the area where stripped/removed and shall be used for restoration on that particular area. Any topsoil removed from permanently converted agricultural areas (e.g. permanent roads, etc.) should be temporarily stockpiled and eventually spread evenly in adjacent agricultural areas within the project Limits of Disturbance (LOD); however not to significantly alter the hydrology of the area. Clearly designate topsoil stockpile areas and topsoil disposal areas in the field and on construction drawings; changes or additions to the designated stockpile areas may be needed based on field conditions in consultation with the EM. Sufficient LOD (as designated on the site plan or by the EM) area should be allotted to allow adequate access to the stockpile for topsoil replacement during restoration.
 - Topsoil stockpiles on agricultural areas left in place prior to October 31st should be seeded with Aroostook Winter Rye or equivalent at an application rate of three bushels (168 lbs.) per acre and mulched with straw mulch at rate of two to three bales per 1000 Sq. Ft.
 - Topsoil stockpiles left in place between October 31st and May 31st should be mulched with straw at a rate of two to three bales per 1000 Sq. Ft. to prevent soil loss.
- The surface of access roads located outside of the generation facility's security fence and constructed through agricultural fields shall be level with the adjacent field surface. If a level road design is not

³ The Limits of Disturbance (LOD) includes all project related ground disturbances and all areas within the project's security fencing.

feasible, all access roads should be constructed to allow a farm crossing (for specific equipment and livestock) and to restore/ maintain original surface drainage patterns.

- Install culverts and/or waterbars to maintain or improve site specific natural drainage patterns.
- Do not allow vehicles or equipment outside the planned LOD without the EM seeking prior approval from the landowner (and/or agricultural producer), and associated permit amendments as necessary. Limit all vehicle and equipment traffic, parking, and material storage to the access road and/or designated work areas, such as laydown areas, with exception the use of low ground pressure equipment.⁴ Where repeated temporary access is necessary across portions of agricultural areas outside of the security fence, preparation for such access should consist of either stripping / stockpiling all topsoil linearly along the access road, or the use of timber matting.
- Proposed permanent access should be established as soon as possible by removing topsoil according to the depth of topsoil as directed by the EM. Any extra topsoil removed from permanently converted areas (e.g. permanent roads, equipment pads, etc.) should be temporarily stockpiled and eventually spread evenly in adjacent agricultural areas within the project Limits of Disturbance (LOD); however not to significantly alter the hydrology of the area.
- When open-cut trenching is proposed, topsoil stripping is required from the work area adjacent to the trench (including segregated stockpile areas and equipment access). Trencher or road saw like equipment are not allowed for trench excavation in agricultural areas, as the equipment does not segregate topsoil from subsoil. Horizontal Directional Drilling (HDD) or equivalent installation that does not disrupt the soil profile, may limit agricultural ground disturbances. Any HDD drilling fluid inadvertently discharged must be removed from agricultural areas. Narrow open trenches less than 25 feet long involving a single directly buried conductor or conduit (as required) to connect short rows within the array, are exempt from topsoil segregation.
- Electric collection, communication and transmission lines installed above ground can create long term interference with mechanized farming on agricultural land. Thus, interconnect conductors outside of the security fence must be buried in agricultural fields wherever practicable. Where overhead utility lines are required, (including Point(s) of Interconnection) installation must be located outside field boundaries or along permanent access road(s) wherever possible. When overhead utilities must cross farmland, minimize agricultural impacts by using taller structures that provide longer spanning distances and locate poles on field edges to the greatest extent practicable.
- All buried utilities located **within** the generation facility's security fence must have a minimum depth of 18-inches of cover if buried in a conduit and a minimum depth of twenty-four inches of cover if directly buried (e.g. not routed in conduit).⁵
- The following requirements apply to all buried utilities located **outside** of the generation facility security fence:
 - In cropland, hayland, and improved pasture buried electric conductors must have a minimum depth of 48-inches of cover. In areas where the depth of soil over bedrock is less than 48-inches, the

⁴ low ground pressure vehicles that do not result in a visible rut that alters soil compaction.

⁵ Burial of electrical conductors located within the energy generation facility may be superseded by more stringent updated electrical code or applicable governing code.

electric conductors must be buried below the surface of the bedrock if friable/rippable, or as near as possible to the surface of the bedrock.

- In unimproved grazing areas or on land permanently devoted to pasture the minimum depth of cover must be 36-inches.
- Where electrical conductors are buried directly below the generation facility's access road or immediately adjacent (at road edge) to the access road, the minimum depth of cover must be 24-inches. Conductors must be close enough to the road edge as to be not subject to agricultural cultivation / s b-soiling.
- When buried utilities alter the natural stratification of soil horizons and natural soil drainage patterns, rectify the effects with measures such as subsurface intercept drain lines. Consult the local Soil and Water Conservation District concerning the type of intercept drain lines to install to prevent surface seeps and the seasonally prolonged saturation of the conductor installation zone and adjacent areas. Install and/or repair all drain lines according to Natural Resources Conservation Service conservation practice standards and specifications. Drain tile must meet or exceed the AASHTO M-252 specifications. Repair of subsurface drains tiles should be consistent with the NYSDAM's details for "*Repair of Severed Tile Line*" found in the pipeline drawing A- (<http://www.agriculture.ny.gov/ap/agsservices/Pipeline-Drawings.pdf>).
- In pasture areas, it may be necessary to construct temporary fencing (in addition to the Project's permanent security fences) around work areas to prevent livestock access to active construction areas and areas undergoing restoration. For areas returning to pasture, temporary fencing will be required to delay the pasturing of livestock within the restored portion of the LOD until pasture areas are appropriately revegetated. Temporary fencing including the project's required temporary access for the associated fence installations should be included within the LOD as well as noted on the construction drawings. The Project Company will be responsible for maintaining the temporary fencing until the EM determines that the vegetation in the restored area is established and able to accommodate grazing. At such time, the Project Company should be responsible for removal of the temporary fences.

Post-Construction restoration requirements applicable to continued use agricultural areas that suffered ground disturbance due to construction activities (typically lands outside of the developed project's security fence).

- All construction debris in active agriculture areas including pieces of wire, bolts, and other unused metal objects will need to be removed and properly disposed of as soon as practical to prevent mixing with any topsoil.
- Excess concrete will not be buried or left on the surface in active agricultural areas. Concrete trucks will be washed outside of active agricultural areas. Remove all excess subsoil and rock unearthed from construction related activities occurring in areas intended to return to agricultural use. On-site disposal of such material is not permissible in active agricultural lands. Designated spoil disposal locations should be specified in the associated construction plans. If landowner agreements, LOD boundary, or Project's land use approvals do not allow for on-site disposal, material must be removed from the site.⁶

⁶ Any permits necessary for disposal under local, State and/or federal laws and regulations must be obtained by the facility operator, with the cooperation of the landowner when required.

- Excess stripped topsoil shall not be utilized for fill within the project area. Any extra topsoil removed from permanently impacted areas (e.g. roads, equipment pads, etc.) should be evenly spread in adjacent agricultural project areas, however not to significantly alter the hydrology of the area.
- Regrade all access roads outside of the security fencing (as determined necessary by the EM), to allow for farm equipment crossing and restore original surface drainage patterns, or other drainage pattern incorporated into the design.
- Repair all surface or subsurface drainage structures damaged during construction as close to preconstruction conditions as possible, unless said structures are to be removed as part of the project design. Correct any surface or subsurface drainage problems resulting from construction of the solar energy project with the appropriate mitigation as determined by the Environmental Monitor, Soil and Water Conservation District and the Landowner.
- On agricultural land needing restoration because of ground disturbance, postpone any restoration practices until favorable (workable, relatively dry) topsoil/subsoil conditions exist. Restoration must not be conducted while soils are in a wet or plastic state of consistency. Stockpiled topsoil must not be regraded, and subsoil must not be decompacted until plasticity, as determined by the Atterberg field test, is adequately reduced. No permanent project restoration activities shall occur in agricultural areas between the months of October through May unless favorable soil moisture conditions exist.
- In all continued use agricultural land where the topsoil was stripped, subsoil decompaction shall be conducted prior to topsoil replacement. Following construction, all such areas will be decompacted to a depth of 18 inches with a tractor mounted deep ripper or heavy-duty chisel plow. Soil compaction results shall be no more than 250 pounds per square inch (PSI) throughout the decompacted 18 inches as measured with a soil penetrometer. Following decompaction, all rocks 4 inches and larger in size unearthed from decompaction will be removed from the surface of the subsoil prior to replacement of the topsoil. The topsoil will be replaced to original depth and the original contours will be reestablished where possible. All rocks 4 inches and larger from topsoil shall be removed from the surface of the topsoil. Subsoil decompaction and topsoil replacement must be avoided after October 1, unless approved on a site-specific basis by the landowner in consultation with NYSDAM. All parties involved must be cognizant that areas restored after October 1st may not obtain sufficient growth for stabilization⁷ to prevent erosion over the winter months. If areas are to be restored after October 1st, necessary provisions must be made to prevent potential springtime erosion, as well as restore any eroded areas in the springtime, to establish proper growth. Excess stripped topsoil shall be evenly spread in the adjacent project areas, or adjacent agricultural areas (within the LOD), however, not to significantly alter the hydrology of the area.
- In all continued use agricultural areas where the topsoil was not stripped, including timber matted areas, the EM shall determine appropriate activities to return the area to agricultural use. These activities may include decompaction, rock removal, and revegetation. Soil compaction should be tested in the affected areas and the affected area's adjacent undisturbed areas using an appropriate soil penetrometer or other soil compaction measuring device as soon as soils achieve moisture equilibrium with adjacent unaffected areas. Compaction tests will be made at regular intervals of distance throughout the affected areas, including each soil type identified within the affected areas. Soil compaction results shall be measured with a soil penetrometer not exceeding more than 250 pounds per square inch (PSI), by

⁷ Sufficient growth for stabilization should be determined by comparison with unaffected crop production. Annual crops restored after normal planting window (as determined by the landowner or associated producer) should be stabilized with Aroostook Winter Rye at the rate of 150/100 lbs. per acre (broad cast/drill seeder).

comparing probing depths of both the affected and unaffected areas. Where representative soil density of the affected area's collective depth measurements present compaction restrictions exceeding an acceptable deviation of no more than 20% from the adjacent undisturbed area's mean soil density, additional decompaction may be required to a depth of 18-inches with a tractor mounted deep ripper or heavy-duty chisel plow. Following decompaction, remove all rocks unearthed from decompaction activities 4 inches and larger in size from the surface. Revegetation shall be performed in accordance with the instructions below.

- Seed all agricultural areas from which the vegetation was removed or destroyed with the seed mix specified by the landowner/agriculture producer or as otherwise recommended in the Department's fertilizer, lime and seeding guideline: [\[https://www.agriculture.ny.gov/ap/agservices/Fertilizer_Lime_and_Seeding_Recommendations.pdf\]](https://www.agriculture.ny.gov/ap/agservices/Fertilizer_Lime_and_Seeding_Recommendations.pdf). Soil amendments should be applied as necessary so that restored agricultural areas' soil properties, at minimum, reasonably reflect the pre-construction soil test results or as otherwise agreed to by the involved parties to ensure continued agricultural use. All parties must be cognizant that areas restored after October 1st may not obtain sufficient growth to prevent erosion over the winter months. If areas are to be restored after October 1st, necessary provisions must be made to restore and/or re-seed any eroded or poorly germinated areas in the springtime, to establish proper growth.

Monitoring and Remediation

Project Companies shall provide a monitoring and remediation period of one complete growing season following the date upon which the desired crop is planted. All projects subject to NYS Public Service Law Article 10 will provide a monitoring period of two complete growing seasons following the date upon which the project achieves the establishment of the desired crop.

On site monitoring shall be conducted seasonally at least three times during the growing season (Spring, Summer, Fall). Monitoring is required to identify any remaining impacts directly associated with the construction of the project on agricultural lands proposed to remain or resume agriculture production, including the effects of climatic cycles such as frost action, precipitation and growing seasons to occur, from which various monitoring observations can be made. NYSDAM expects the Project Company (or its contractor) to retain the EM for follow-up monitoring and remediation (as needed) in agricultural areas. Monitoring is limited to the restored agricultural area. Non-project related impacts affecting the restored project area will be discussed with NYSDAM staff and considered for omission from future monitoring and remediation. The EM is expected to record the following observations from onsite inspections:⁸

- **Topsoil Thickness and Trench Settling** – The EM observations may require small hand dug holes to observe the percentage of settled topsoil in areas where the topsoil was stripped, or trenching was performed without stripping topsoil. Observations concerning depth of topsoil deficiencies shall require further remediation by re-appropriating additional topsoil. Acceptable materials for remediation are: known areas of native excess topsoil (according to records of project specific excess topsoil disposal spread within the original LOD) or imported topsoil free of invasive species that is consistent with the quality of topsoil on the affected site.

⁸ The activities that follow are not necessary for restored agricultural lands on which the farmer or landowner has commenced activities, including agricultural activities or other use that tend to reverse restoration or create conditions that would otherwise trigger restoration. Should NYSDAM contend upon inspection that conditions indicate that post-construction restoration activities were improperly performed or insufficient, NYSDAM may inform the project company and NYSERDA for further investigation and remediation.

- **Excessive Rock (>4-inches)** - Determined by a visual inspection of disturbed areas as compared to unaffected portions of the same field located outside the construction area. Observations concerning excess stone material in comparison to off-site conditions shall require further remediation including removal and disposal of all excess rocks and large stones.
- **Soil Compaction** - Project affected agricultural soils should be tested using an appropriate soil penetrometer or other soil compaction measuring device. Compaction tests will be made at regular intervals of distance throughout the access or work areas, including each soil type identified on the affected agricultural areas. Where representative soil density of the affected area exceeds the representative soil density of the unaffected areas, additional decompaction may be required. Consultation with NYSDAM staff and the agricultural producer(s) should be conducted prior to scheduling additional decompaction. If warranted, decompaction to a depth of 18-inches with a tractor mounted deep ripper or heavy-duty chisel plow. Restoration of displaced topsoil to original depth and re-establish original contours where possible. Decompaction deep shattering will be applied during periods of relatively low soil moisture to ensure the desired mitigation and to prevent additional soil compaction. Oversized stone/rock (Four-inches) material that is uplifted/unearthed to the surface as a result of the deep shattering will be removed.
- **Drainage** – The EM shall visually inspect the restored agricultural areas in search of pervasive stunted crop growth due to seasonal saturation, not previously experienced at the site and not resulting from the agricultural producer’s irrigation management or due to excessive rainfall. Identified areas of stunted crop growth shall be compared to the nearest undisturbed adjacent areas under a substantially equivalent terrain and crop management plan. Drainage observations should be evaluated to determine if the project affected surface or sub-surface drainage during construction or restoration. Project caused drainage issues affecting or likely to reduce crop productivity of the adjacent areas will have to be remediated via a positive surface drainage, sub-surface drainage repair or an equivalent.
- **Agriculture Fencing and Gates** – The EM shall inspect Project associated fencing and gates (installed, altered or repaired) within the Project’s LOD associated with agricultural activities for function and longevity. The Project Company is responsible during the Monitoring and Remediation Phase for maintaining the integrity of Project associated fencing and gates.

The Project Company (or its contractor) shall consolidate each applicable growing season’s observations into an annual report during the monitoring period and shall be provided upon request to NYSDAM. Annual reports should include date stamped photographs illustrating crop growth in comparison with unaffected portions the agricultural areas.

The EM shall record observations of the establishment of the desired crop and subsequent crop productivity within restored agricultural areas and shall be evaluated by comparing its productivity to that of the nearest adjacent undisturbed agricultural land of similar crop type within the same field. If a decline in crop productivity is apparent the Project Company as well as other appropriate parties must determine whether the decline is due to project activities. If project activities are determined to be the primary detrimental factor, the project EM will notify NYSDAM concerning unsuccessful restoration and to potentially schedule a NYSDAM staff field visit. If project restoration is determined to be insufficient, the Project Company will develop a plan for appropriate rehabilitation measures to be implemented. NYSDAM staff will review and approve said plan prior to implementation. Additional monitoring may be required depending on additional restoration activities needed.

The Project Company is not responsible for site conditions and/or potential damages attributable to the agricultural producer’s land use management or others’ land use management.

Decommissioning

If the operation of the generation facility is permanently discontinued, remove all above ground structures (including panels, racking, signage, equipment pad, security fencing) and underground utilities if less than 48-inches deep. All concrete piers, footers, or other supports must be removed to a minimum depth of 48-inches below the soil surface. The following requirements apply to electric conductors located at the respective range of depth below the surface:

- 48-inches plus: All underground electric conduits and direct buried conductors may be abandoned in place. Applicable conduit risers must be removed, and abandoned conduit must be sealed or capped to avoid a potential to direct subsurface drainage onto neighboring land uses.
- Less than 48 inches: All underground direct buried electric conductors and conductors in conduit and associated conduit with less than 48-inches of cover must be removed, by means of causing the least amount of disturbance as possible.

Access roads in agricultural areas must be removed, unless otherwise specified by the landowner. If access is to be removed, topsoil will have to be returned from recorded project excess native topsoil disposal areas, if present, or imported topsoil free of invasive species that is consistent with the quality of topsoil on the affected site. Restore all areas intended for agricultural production, according to recommendations by the current landowner or leasing agricultural producer, and as required by any applicable permit, the Soil and Water Conservation District, and NYSDAM.

Monitoring and restoration requirements in accordance to the prior sections of these guidelines, will be required for the decommissioning restoration. NYSDAM requires notice before the Project Company undertakes decommissioning.

Leatherleaf Solar, LLC (Project Company) hereby agrees to use best efforts to adopt and employ the provisions of the NYSDAM Guidelines for Agricultural Mitigation for Solar Energy Projects in all material aspects of the construction, post construction and decommissioning of this project. Where Project Company determines that it cannot perform an activity in a manner that meets the material terms of any provision of the Guidelines, the Project Company or its Environmental Monitor will notify NYSDAM and make good faith efforts to devise an alternative solution that will mitigate adverse agricultural impacts.

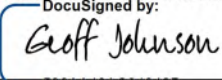
DocuSigned by:

 536AA40AC84042D...

 Signature

3/22/2023

 Date

EXHIBIT J. VISUAL IMPACT ASSESSMENT

VISUAL IMPACT ASSESSMENT

for

**LEATHERLEAF SOLAR, LLC
7501 Ivision Road
Town of Byron, New York**

Prepared For:

**Leatherleaf Solar, LLC
PO Box 173
Latham, NY 12110**

Prepared By:

**Langan Engineering, Environmental, Surveying,
Landscape Architecture and Geology, D.P.C.
One North Broadway, Suite 910
White Plains, New York 10601**

February 24, 2023

LANGAN

Project No.: 190087901

Table of Contents

1	Executive Summary	1
2	Project Description.....	1
2.1	Existing Conditions and Visual Environment.....	1
2.2	Proposed Development	2
3	Methodology	2
3.1	Inventory of Aesthetic Resources & Local Locations of Concern	2
3.2	Viewshed Analysis	4
4	Potential Visual Impacts, Significance & Mitigation	5
5	Conclusion.....	5

Tables

Table 3-1: Inventory of Scenic/Aesthetic Resources.....	3
---	---

Photographs

Photo 1: Looking north along Ivision Road	1
Photo 2: Looking east from Ivision Road	2

Figures

Figure 1:	Site Location Map
Figure 2:	Viewshed Analysis Map without Trees
Figure 3:	Viewshed Analysis Map with Trees

1 Executive Summary

This Visual Impact Assessment (VIA) and accompanying visual renderings has been prepared in general conformance with New York State Department of Environmental Conservation (NYSDEC) Policy DEP-00-2, "Assessing and Mitigating Visual Impacts." The Applicant, Leatherleaf Solar, LLC, is proposing to development a property located on Ivision Road in the Town of Byron, New York. The project, Leatherleaf Solar, LLC, is a large-scale solar energy system that consists of solar racks, permeable haul road, perimeter fencing, swales, and stormwater management practices.

As part of this VIA, a viewshed analysis has been prepared which identifies areas with a line of sight to the project. The viewshed analysis was overlaid with the aesthetic resources to determine if any visually sensitive areas have a potential to see the proposed site. Based on the analysis, it is anticipated that the project will not cause significant visual or aesthetic impacts.

2 Project Description

2.1 Existing Conditions and Visual Environment

Leatherleaf Solar, LLC is located on a 179.9 acre property along Ivision Road in the Town of Byron, New York (see [Figure 1](#)). The property is bounded on the west side by Ivision Road, and on the north side by CSX Rail line, and on the south and east side residential and agricultural properties. The majority of the site is farmland with instances of existing woodland area. The slopes are between 1 percent and 5 percent with a change in grade of approximately 20 feet from the north side of the site to the south side of the site.

Photographs of the surrounding areas are shown below.



Photo 1: Looking north along Ivision Road



Photo 2: Looking east from Ivision Road

2.2 Proposed Development

The project is a large-scale solar energy system that consists of solar racks with associated appurtenances, two equipment pads, a 20-foot wide permeable haul road, perimeter fencing, swales, and stormwater management basins. The permeable haul road will provide access from Richmond Center Road. The solar racks will be a maximum of 12 feet tall at their highest point above grade. The transformer will be approximately 6 feet tall and the switchboard will be approximately 8 feet tall, both of which will be mounted onto the equipment pads. The utility poles at the proposed interconnect locations will be approximately 40 feet tall. The fence will be a 7 foot tall chainlink fence with 12 inches of 3 strand barbwire.

3 Methodology

This Visual Impact Assessment has been prepared in general conformance with New York State Department of Environmental Conservation (NYSDEC) Policy DEP-00-2, "Assessing and Mitigating Visual Impacts." Specific methodologies employed for each portion of the assessment are described in the subsections below.

3.1 Inventory of Aesthetic Resources & Local Locations of Concern

Aesthetic resource information was compiled from Geographic Information System (GIS) datasets provided by NYSDEC, New York State Department of Transportation, New York Natural Heritage Program, US Forest Service, the National Park Service, US Bureau of Land Management, and US Fish and Wildlife Service. Datasets were searched for keywords relating to each of the categories of the Inventory of Aesthetic Resources (listed below). All relevant features within a 5-mile radius are included on the viewshed figures (see [Figure 2](#) and [Figure 3](#)).

The resources considered include:

- A property on or eligible for inclusion in the National or State Register of Historic Places;

- State Parks;
- Urban Cultural Parks;
- The State Forest Preserve;
- National Wildlife Refuges;
- National Natural Landmarks;
- The National Park System, Recreation Areas, Seashores, Forests;
- Rivers designated as National or State Wild, Scenic or Recreational;
- A site, area, lake, reservoir or highway designated or eligible for designation as scenic;
- Scenic Areas of Statewide Significance;
- A State or federally designated trail, or one proposed for designation;
- Adirondack Park Scenic Vistas;
- State Nature and Historic Preserve Areas;
- Palisades Park; and
- Bond Act Properties purchased under Exceptional Scenic Beauty or Open Space category.

The table below outlines the resources that appear within a 5-mile radius of the property.

Table 3-1: Inventory of Scenic/Aesthetic Resources

Number	Resource	Description
1	Byron-Bergen Junior/Senior High School	Educational Placemark (located 2.5 miles northeast of the site)
2	Byron-Bergen Elementary School	Educational Placemark (located 2.6 miles northeast of the site)
3	Byron Airpark	Cultural Placemark (located 1.8 miles north of the site)
4	Stafford Private Airport	Cultural Placemark (located 2.6 miles south of the site)
5	Endangered, Threatened or Rare Plants	Important Area (Plants) (located 2.7 miles northeast of the site)
6	Endangered or Threatened Animals	Important Area (Animals) (located 4.2 miles northeast of the site)
7	Rare Animals	Important Area (Animals) (located 3.3 miles northeast of the site)
8	Rare Freshwater Mussels	Important Area (Animals) (closest point located 1.6 miles northwest of the site)
9	State Highway 33	Highway (closest point located 1.1 miles south of the site)
10	County Road 31	Highway (closest point located 1.7 miles east of the site)
11	State Highway 262	Highway (closest point located 1.9 miles north of the site)
12	County Road 19A	Highway (closest point located 2.7 miles west of the site)
13	Interstate 490	Highway (closest point located 3.8 miles southeast of the site)
14	New York State Thruway	Highway (closest point located 1.3 miles south of the site)
15	State Highway 237	Highway (closest point located 1.3 miles west of the site)

Number	Resource	Description
16	County Road 14	Highway (project site has frontage along this road)
17	County Road 7	Highway (closest point located 0.7 miles southwest of the site)
18	County Road 8	Highway (closest point located 3.8 miles west of the site)
19	County Road 34	Highway (closest point located 3.5 miles southwest of the site)
20	County Road 42	Highway (closest point located 1.3 miles west of the site)
21	County Road 13	Highway (closest point located 4.7 miles west of the site)
22	State Highway 5	Highway (closest point located 4.7 miles south of the site)
23	Bergen Swamp	Important Area (Natural Communities) (located 3.1 miles northeast of the site)
24	Bergen Swamp East Lobe	Important Area (Natural Communities) (located 4.7 miles northeast of the site)
25	Oatka Creek Slopes	Important Area (Natural Communities) (located 4.9 miles southeast of the site)
26	CSX Transportation	Railway (project site has frontage along this rail)

3.2 Viewshed Analysis

As part of the visual impact assessment, two viewshed analyses of the site were prepared using GIS software. The ground elevation within the study area were modeled from a 1/3-arc-second Digital Elevation Model (DEM) that was published by the United States Geological Survey (USGS) on 1/28/2022.

The first analysis ([Figure 2](#)) shows the ground elevation within a 5-mile radius around the site, without accounting for any vegetation. The second analysis ([Figure 3](#)) is based on the first, and also includes vegetation within the site boundary, over the ground elevations. The analysis used an approximate 60-foot tree height. Vegetation outside of the site was not considered in the analysis, resulting in a conservative analysis. Both analyses used a 12-foot-high offset of the ground elevations to represent the proposed solar array.

The aesthetic/scenic resources described in Table 3-1 above were overlaid with [Figure 2](#) and [Figure 3](#). Based on the analysis, there are two scenic/aesthetic resources that could have a view of the site if there was not deciduous tree cover, which are identified as resource #1 and #2. A summary of the locations is provided below.

- [Resource #1](#): Located approximately 2.5 miles northeast of the site. This location could have a view of the site without any vegetation, since there is limited wooded areas between the resource and the project site to act as natural screening. When modeled with the existing vegetation and based on the location of the existing topography in the vicinity of this location, it is unlikely that the site will be visible from this location.

- Resource #2: Located approximately 2.6 miles northeast of the site. This location could have a view of the site without any vegetation, since there is limited wooded areas between the resource and the project site to act as natural screening. When modeled with the existing vegetation and based on the location of the existing topography in the vicinity of this location, it is unlikely that the site will be visible from this location.

4 Potential Visual Impacts, Significance & Mitigation

We prepared and considered the viewshed analysis described in the previous sections to assess the visual impact of the proposed solar site on the surrounding area. We focused on the impact to state aesthetic resources, as defined by NYSDEC, and potential local locations of concern.

As determined by the viewshed analyses, the site will be minimally visible from Ivision Road and will be screened from the south and east sides with an evergreen screen to mitigate the views from Freeman Road and Coward Road.

5 Conclusion

This Visual Impact Assessment for the Leatherleaf Solar, LLC has been developed in accordance with the New York State Department of Environmental Conservation (NYSDEC) guidelines. This Visual Impact Assessment identifies potential visual impacts and the visual remediation measures to be implemented on site. In the opinion of the Visual Impact Assessment preparer, the proposed project will not have adverse impacts if the evergreen screening and privacy fence that is proposed for mitigation is properly installed and maintained in accordance with the requirements outlined on the accompanying project plans.

\\langan.com\data\WPW\data2\190087201\Project Data\Record Data\Reports\2022-12-27\2022-12-27 Honeoye Solar VIA.docx

LEATHERLEAF SOLAR, LLC
7501 Ivision Road
Town of Byron, New York

Figures

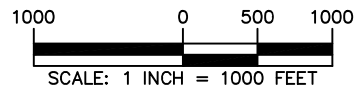
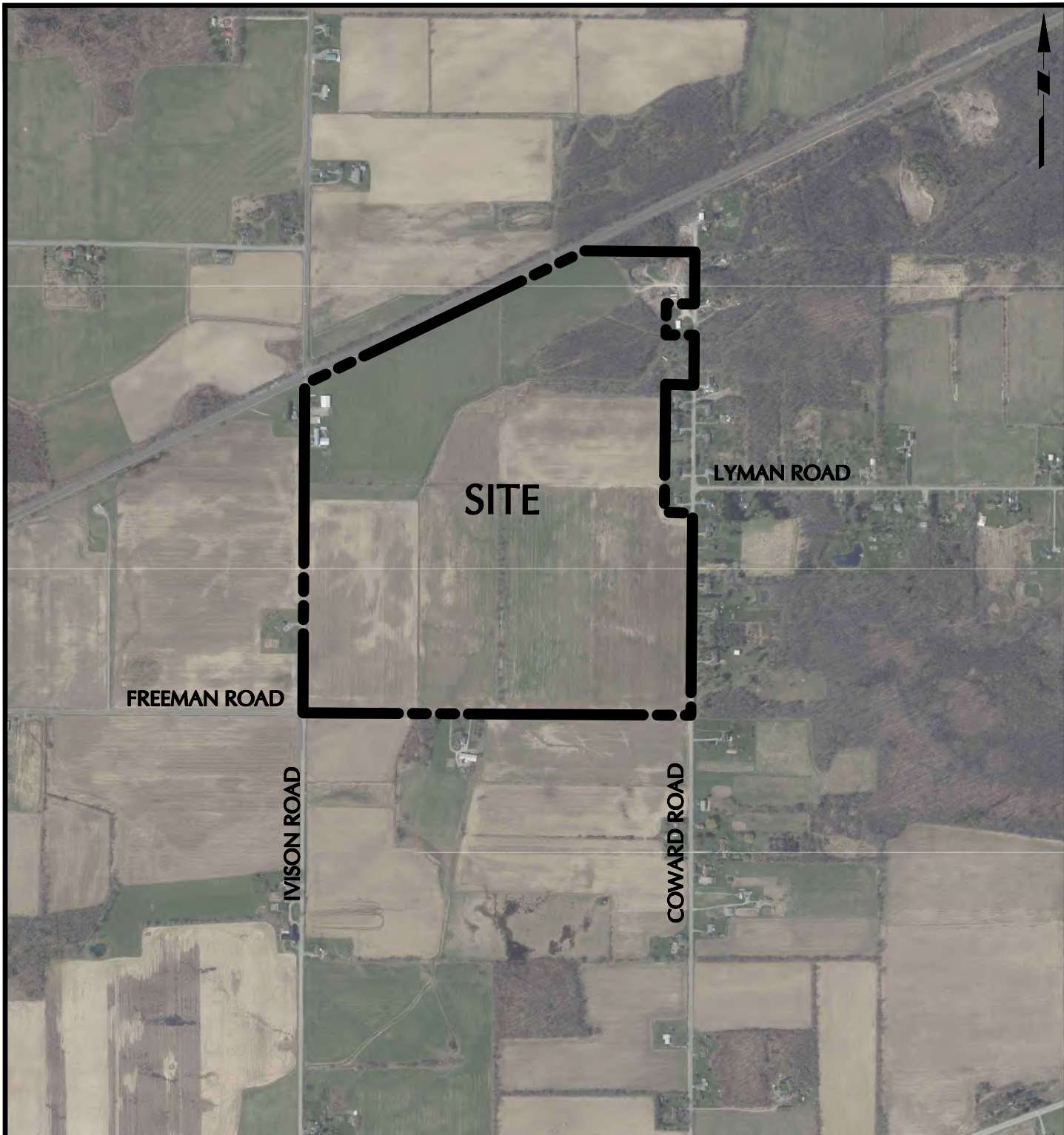

WARNING: IT IS A VIOLATION OF THE NYS EDUCATION LAW ARTICLE 145 FOR ANY PERSON, UNLESS HE OR SHE IS ACTING UNDER THE DIRECTION OF A LICENSED PROFESSIONAL ENGINEER, LAND SURVEYOR OR GEOLOGIST, TO ALTER THIS ITEM IN ANY WAY.

<p>LANGAN Langan Engineering, Environmental, Surveying, Landscape Architecture, and Geology, D.P.C. One North Broadway, Suite 910 White Plains, NY 10601 T: 914.323.7400 F: 914.323.7401 www.langan.com</p>	Project	Drawing Title	Project No.	Figure
	LEATHERLEAF SOLAR, LLC	SITE LOCATION MAP	190087901	FG01
	TAX ID: 9-1-7.113 TOWN OF BYRON		Date	
	GENESEE COUNTY NEW YORK		02/24/2023	
			Drawn By	Sheet 1 of 6
			GN	
			Checked By	
			SS	

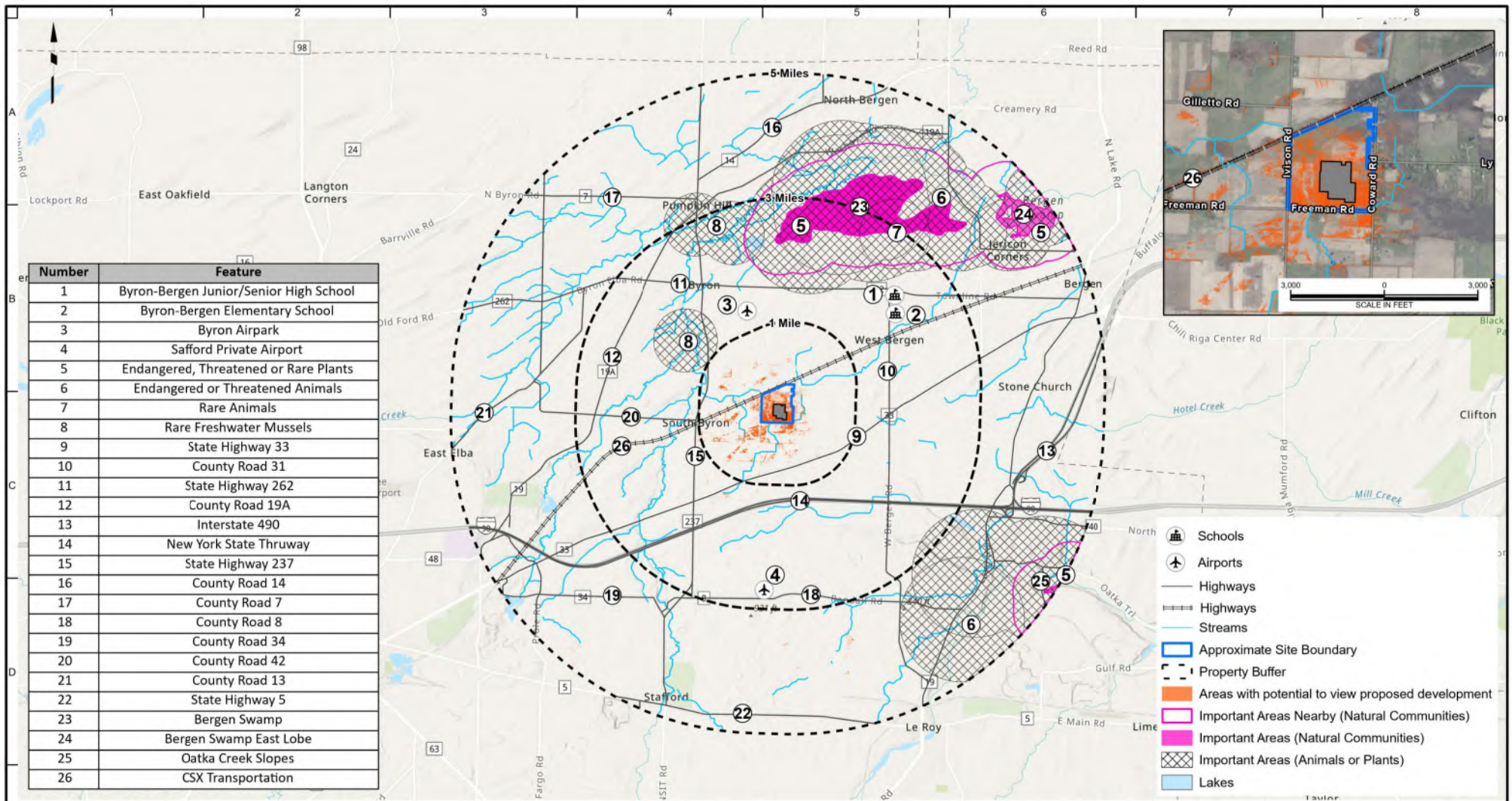

Number	Feature
1	Byron-Bergen Junior/Senior High School
2	Byron-Bergen Elementary School
3	Byron Airpark
4	Safford Private Airport
5	Endangered, Threatened or Rare Plants
6	Endangered or Threatened Animals
7	Rare Animals
8	Rare Freshwater Mussels
9	State Highway 33
10	County Road 31
11	State Highway 262
12	County Road 19A
13	Interstate 490
14	New York State Thruway
15	State Highway 237
16	County Road 14
17	County Road 7
18	County Road 8
19	County Road 34
20	County Road 42
21	County Road 13
22	State Highway 5
23	Bergen Swamp
24	Bergen Swamp East Lobe
25	Oatka Creek Slopes
26	CSX Transportation

- Schools
- Airports
- Highways
- Streams
- Approximate Site Boundary
- Property Buffer
- Areas with potential to view proposed development
- Important Areas Nearby (Natural Communities)
- Important Areas (Natural Communities)
- Important Areas (Animals or Plants)
- Lakes

Notes:
 1. Viewshed analysis conducted using 2019 New York State Lidar: Erie, Genesee, and Livingston Counties, provided by the New York State Office of Information Technology Services.
 2. World topographic basemap is provided through Langan's Esri and ArcGIS software licensing and ArcGIS online.
 3. Sensitive receptor data provided by the NYSDEC.
 4. Transportation data provided by the New York State GIS Program.

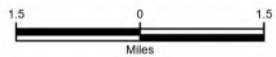

LANGAN
 Langan Engineering, Environmental, Surveying,
 Landscape Architecture and Geology, D.P.C.
 1 North Broadway, Suite 910
 White Plains, NY 10601
 T: 914.323.7400 F: 914.323.7401 www.langan.com

Project
LEATHERLEAF
 BYRON
 GENESEE COUNTY NEW YORK

Figure Title
VIEWSHED ANALYSIS MAP WITH TREE CANOPY

Project No.
 190087901
 Date
 1/10/2023
 Scale
 1"=1.5 miles
 Drawn By
 MG

Figure No.
2

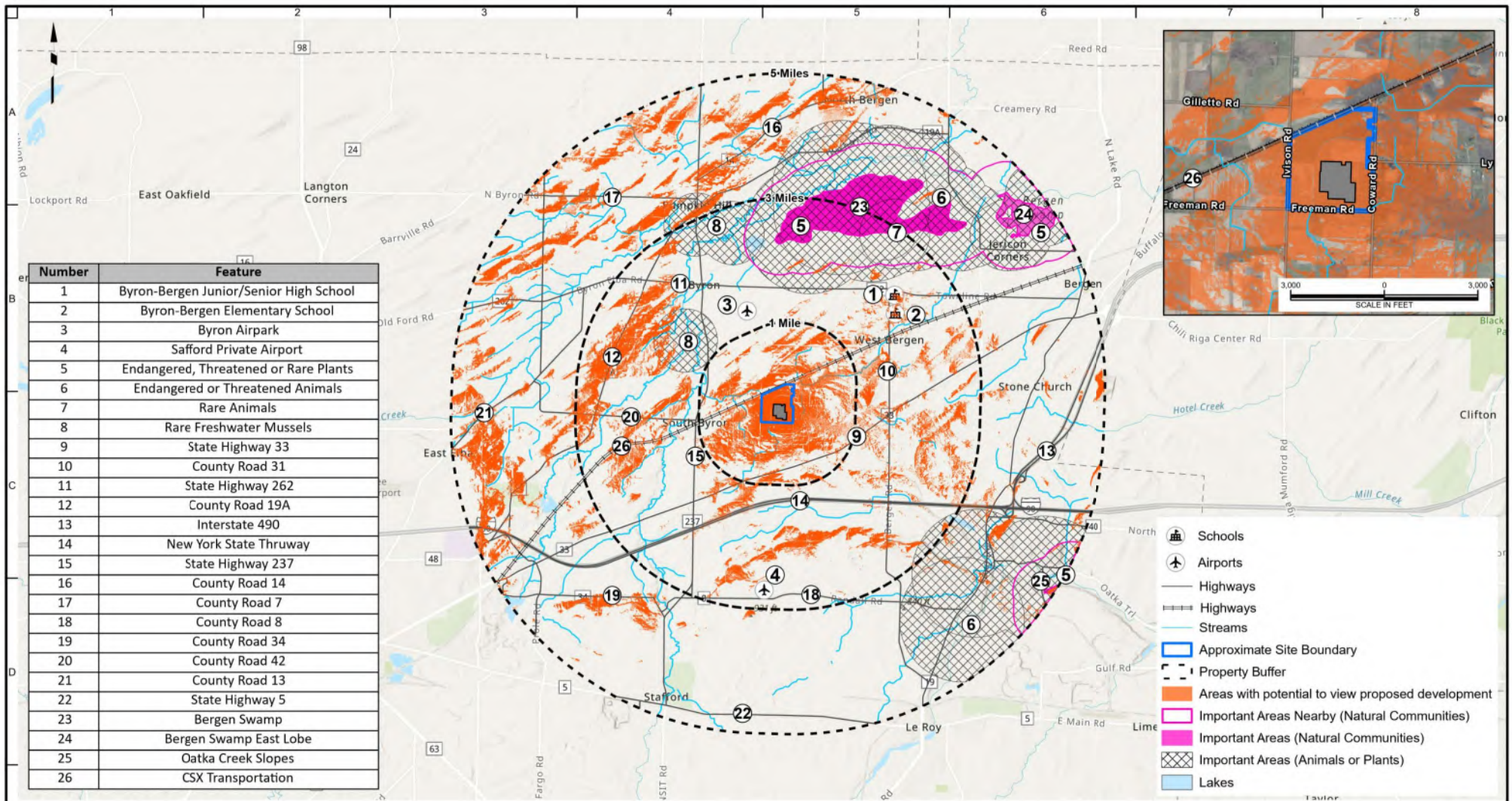

Number	Feature
1	Byron-Bergen Junior/Senior High School
2	Byron-Bergen Elementary School
3	Byron Airpark
4	Safford Private Airport
5	Endangered, Threatened or Rare Plants
7	Rare Animals
8	Rare Freshwater Mussels
9	State Highway 33
10	County Road 31
11	State Highway 262
12	County Road 19A
13	Interstate 490
14	New York State Thruway
15	State Highway 237
16	County Road 14
17	County Road 7
18	County Road 8
19	County Road 34
20	County Road 42
21	County Road 13
22	State Highway 5
23	Bergen Swamp
24	Bergen Swamp East Lobe
25	Oatka Creek Slopes
26	CSX Transportation

- Schools
- Airports
- Highways
- Streams
- Approximate Site Boundary
- Property Buffer
- Areas with potential to view proposed development
- Important Areas Nearby (Natural Communities)
- Important Areas (Natural Communities)
- Important Areas (Animals or Plants)
- Lakes

Notes:
 1. Viewshed analysis conducted using 2019 New York State Lidar: Erie, Genesee, and Livingston Counties, provided by the New York State Office of Information Technology Services.
 2. World topographic basemap is provided through Langan's Esri and ArcGIS software licensing and ArcGIS online.
 3. Sensitive receptor data provided by the NYSDEC.
 4. Transportation data provided by the New York State GIS Program.

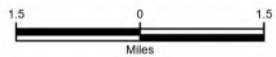

LANGAN

Langan Engineering, Environmental, Surveying, Landscape Architecture and Geology, D.P.C.
 1 North Broadway, Suite 910
 White Plains, NY 10601

T: 914.323.7400 F: 914.323.7401 www.langan.com

Project
LEATHERLEAF
 BYRON
 GENESEE COUNTY NEW YORK

Figure Title
VIEWSHED ANALYSIS MAP WITHOUT TREE CANOPY

Project No.
 190087901
 Date
 1/9/2023
 Scale
 1"=1.5 miles
 Drawn By
 MG

Figure No.
3

EXHIBIT K. TECHNICAL MEMO

Solar Farm Development & Operation



Technical Overview

Solar photovoltaic technology has been in use for well over 50 years. While PV materials and technology have improved over time to be more efficient and cost effective, installation and operation have remained unchanged.

“Photovoltaic,” commonly abbreviated as PV, is simply the technical term for converting the sun’s light into useable electric current.

Solar facilities, often referred to as “solar farms,” passively capture naturally occurring sunlight and convert it to clean, renewable energy on a scale large enough to supply electricity for daily living in our homes, businesses and schools. Each solar farm is a collection of solar panels arranged to gather maximum amounts of sunlight during the day. The panels are linked to inverters and transformers that convert the sunlight into useable electricity, which is then transferred to the existing electrical grid.

Equipment and Construction

Solar facilities are simple constructions that employ the following basic equipment:

- Solar PV panels
- Inverters
- Transformers
- Wires and conductor cables
- Structural racking system for PV modules
- Perimeter fencing

Most sites require minimal grading, and an entire facility can often be installed with minimal soil disturbance. Structural frames (called racks) are driven into the ground with steel beams (called piles), on which PV panels are mounted. The

inverters and transformers, which receive the power from the solar panels, are mounted on top of concrete pads.

The electricity-making process starts with sunlight striking the solar panels. The energy from this action is converted into low-voltage DC electricity. This low-voltage DC electricity is fed into the inverters where it is converted into low-voltage AC electricity, which is then fed into the transformers where the electricity is converted into medium-voltage AC electricity. The medium-voltage electricity is connected to the grid through underground cables.



Solar Panel Technology

Cypress Creek Renewables uses several solar PV panel technologies: Crystalline Silicon (C-Si) and Thin Film (TF). Each type of technology uses slightly different materials, work identically, and are of similar construction.

Crystalline Silicon modules are produced by sourcing extremely high quality, pure silicon or quartz. The silicon is heated until it melts, after which a crystal is grown from a source ingot. The silicon crystal is sliced into thin wafers, mounted onto a durable backing material and encapsulated by tempered glass and an aluminum frame. Thin-film solar modules are made by depositing thin film photovoltaic materials into crystalline layers that are bonded to tempered glass, after which the module is encapsulated by the aluminum frame.

Once finished, the solar PV panels function as a solid-state inert crystal, most similar to a pane of solid glass. The solar panels are expected to work upwards of 40 years before they are recycled to recover the valuable materials contained inside. Encapsulation of the modules prevents penetration of air and moisture from entering the cell and conversely prevents the release of materials out of the module and into the environment.

Source: N.C. Clean Energy Technology Center. Health and Safety Impacts of Solar Photovoltaics. Raleigh: N.C. State University, 2017. https://nccleantech.ncsu.edu/wp-content/uploads/Health-and-Safety-Impacts-of-Solar-Photovoltaics-2017_white-paper.pdf

Sound

The facility's inverters and transformers produce a sound when operating during the hours of peak power production, typically between 10am-2pm. At 150 feet, this sound is inaudible above natural ambient noise in rural areas. The sound created by the inverter during peak power production is typically in the low-range of 65 decibels at a distance of 30 feet—the equivalent of

the sound created during normal conversation. The rest of the facility's equipment does not produce any audible sound and no sound is produced at night.

Source: Peter H. Guldberg. Study of Acoustic and EMF Levels from Solar Photovoltaic Projects. Boston: Massachusetts Clean Energy Center, 2012. <http://files.masscec.com/research/StudyAcousticEMFLevelsSolarPhotovoltaicProjects.pdf>.

Reflection

Solar panels are designed to absorb light from the visible spectrum, not to reflect it, although some upward reflection does occur. To assist light absorption, each PV panel is treated with an anti-reflective coating. Naturally occurring ponds and streams, snow, and even certain kinds of soil and vegetation are similarly reflective. In fact, the sunlight that is reflected away from solar panels produces the same amount of glare as a flat pond or lake.

Additionally, solar panels are mounted at an angle that allows for maximum light to be absorbed throughout the year, which results in the panels facing the sky at shallow angles (typically less than 25 degrees). As a result, what little light is reflected is not visible to ground-level observers.

All solar farms are required to be approved by the FAA as potential glare hazards for aviators. To date, no PV array has been deemed a glare hazard. In fact, there are a significant number of PV power plants built next to highways and around airports.

Source: Evan Riley and Scott Olson. "A Study of the Hazardous Glare Potential to Aviators from Utility-Scale Flat-Plate Photovoltaic Systems." ISRN Renewable Energy (2011), <https://doi.org/10.5402/2011/651857>.



Electro-Magnetic Fields (EMF)

The International Commission on Non-Ionizing Radiation Protection has established 833 milli-Gauss (mG) as the limit for prolonged exposure to electro-magnetic fields. The inverter is the strongest source of magnetic fields in the solar facility with levels varying from 150–500 mG within one to two feet. As an unmanned facility, prolonged exposure is never an issue. The level of EMFs noticed 1–2 feet away from our equipment pad is similar to standing next to your television. At 150 feet, the inverter's magnetic field levels drop below 0.5 mG or less, often falling to the background level of earth's magnetic field of 0.2 mG.

No other solar PV component emits EMFs that are measurable above the earth's magnetic field. There are no EMFs emitted at night.

Sources: Peter H. Guldberg. Study of Acoustic and EMF Levels from Solar Photovoltaic Projects. Boston: Massachusetts Clean Energy Center, 2012. <http://files.masscec.com/research/StudyAcousticEMFLevelsSolarPhotovoltaicProjects.pdf>

Soil Protection

Minimal ground disturbance only occurs during the construction period. Heavy equipment and traffic is restricted to perimeter roads, which comprise less than 0.03 percent of the site area during construction. To further protect against erosion, most roads on the site are re-seeded with vegetation after construction unless otherwise required by the soil conditions or indicated by the jurisdiction.

A detailed erosion and sedimentation control plan is developed for every project so that water-borne runoff is prevented from entering the surrounding environment. Control measures typically include straw bales, hay coil logs, run-off channels, silt fencing, and sediment basins or other state approved soil stabilization control measures. Once constructed, natural vegetative growth is encouraged within the facility to prevent erosion, and the areas where panels are located are not considered impervious.

Dust and Weed Control

During construction, dust levels are kept to a minimum by limiting heavy equipment and traffic to designated perimeter roads and points of site entry. During dry seasons, roads are regularly kept wet to reduce dust. Wet seasons naturally keep dust levels down.

To minimize the encroachment of weeds following construction native grass is planted across the site. The grounds are watered as needed, and weeds are removed during regular maintenance activities.

Source: Jordan Macknick, Brenda Beatty, and Graham Hill. Overview of Opportunities for Co-Location of Solar Energy Technologies and Vegetation. National Renewable Energy Laboratory, 2013. <https://www.nrel.gov/docs/fy14osti/60240.pdf>.

Wildlife Protection

Wildlife is protected by using perimeter fencing to prevent access for large mammals, such as deer. Large animals are excluded from the site because they can interfere with equipment, damage wiring, or injure themselves. In cases when barbed wire is not used, perimeter fence height is increased.

Smaller animals, such as squirrels and birds, can pass throughout the facility following construction. The environment in the solar facility is often conducive to a wildlife habitat because of its natural vegetation, significant amount of shade and relative lack of human disruption.

Wildlife access to electrical equipment is prevented with conduit protection for wires and foam sealing at all equipment entry points.

Source: Damon Turney and Vasilis Fthenakis. "Environmental impacts from the installation and operation of large-scale solar power plants." Renewable and Sustainable Energy Reviews (August 2011): 3261-3270.



Decommissioning

Cypress Creek is committed to responsibly decommissioning all of our projects at the end of their useful lives. Although the mechanism for doing so are market-specific based on local needs and regulations, every project is contractually obligated to decommission per our lease/purchase agreements with our landowner partners. Decommissioning and dismantling of the solar PV power plant is not expected to occur until approximately thirty years after the facility is constructed. The system's equipment, including wires, conductors, and racking, has significant salvage value since it is comprised of useful metals such as copper, aluminum and steel. The PV panels are valuable for their semiconductor materials and rare metals such as silver. At the end of the facility's lifetime, a solar reclamation firm will collect the modules for recycling, the inverters for refurbishing, and the hardware for salvage.

The land is then reseeded with a local seed mix and can be repurposed for agriculture or other uses.

Maintenance

Once constructed, solar farms require minimal maintenance. As such, there is no need to build travel infrastructure to accommodate traffic. Electrical engineers will service the inverters and transformers on average once per quarter. Solar PV panels have a very low failure rate (approximately 1 in 10,000 per year), and are easily replaced from inventory stores.

The panels require no on-site water or chemicals to keep clean. Natural weather conditions, such as snow and rain, occur with enough frequency and quantity to naturally keep the panels clean.

Grass is kept under control by mowing. To maintain weeds, application of weed control products is completed by a licensed herbicide applicator, in accordance with the manufacturer's requirements (incl. Safety Data Sheet); as well as local, State, and Federal regulations. In some regions, sheep grazing within the facility are used to control vegetation. Sites are maintained approximately 5–9 times per year during the growing season, depending on location.

Source: National Rural Electric Cooperative Association. Cooperative Utility PV Field Manual. Department of Energy, 2017. <https://www.cooperative.com/programs-services/bts/documents/sunda/nreca-cooperative-utility-pv-field-manual-vol-ii-final.pdf>.

Safety

Solar facilities do not generate more than one to three vehicle visits per quarter on average, making them insignificant traffic generators that do not create safety issues for the surrounding road networks. By contrast, the average American household generates ~6 vehicle trips per day.

Additionally, solar PV power plants are constructed according to all required building and electrical codes and safety measures. Site plans are approved by local authorities, and regularly visited throughout construction as required by local ordinance or state building code.

Interconnection agreements are carried out as specified by the local utility. Energized system components, such as inverters, are commissioned by the manufacturers' technicians. Solar facilities employ required lock-out measures and safety warnings. A perimeter security fence prevents trespassing and vandalism.

The regular vegetation control methods prevent buildup of debris that could otherwise pose risk of fire material. As such, solar PV facilities pose no increased risk of fires to the surrounding areas.

Vegetation management prevents buildup of debris that could otherwise pose risk of fire material. As such, solar PV facilities pose no increased risk of fires to the surrounding areas.

Sources: Jeff Court, "Photovoltaic Solar Safety Management for Utilities," Incident Prevention Magazine, October 16, 2014, <https://incident-prevention.com/ip-articles/photovoltaic-solar-safety-management-for-utilities>.

National Fire Protection Association, National Electrical Code, 690.1-91, 370.1-120, 376.1-120, 408.1-58, 450.1-48, 480, 490.1-74, 705.1-135, 728, 750.

For more information, visit:
ccrenew.com